

FASCLIC AUTO EZ

Référence(s) : 082 061/071/081/091, 082 101/201/251/301/401.

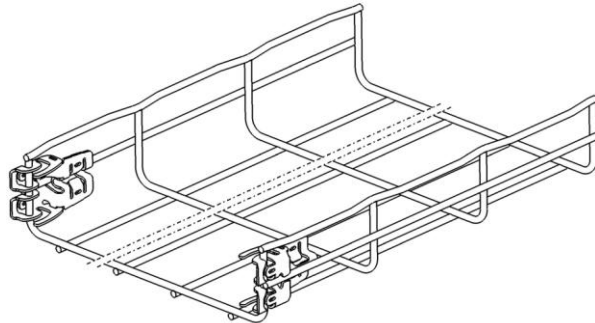

RANGE.

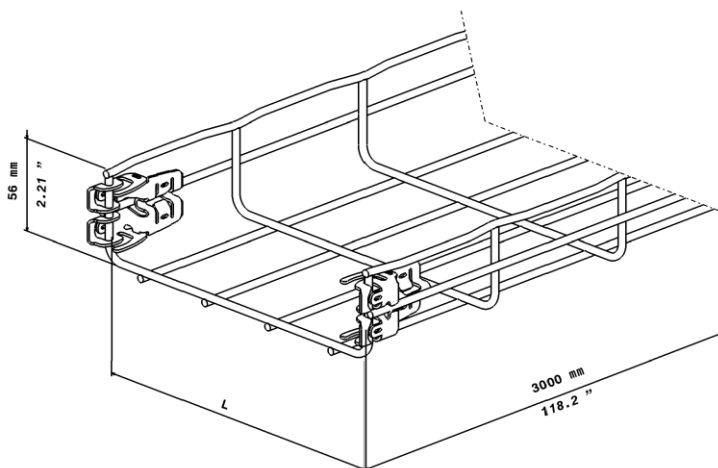

Ref	Code	Poids (kg/ml)	Weight/ (lb/ft)	L (mm)	L (inch)
FCFA 54/50EZ	082 061	0,639	0,429	50	1,97
FCFA 54/100EZ	082 071	0,786	0,528	100	3,94
FCFA 54/150EZ	082 081	1,050	0,706	150	5,91
FCFA 54/200EZ	082 091	1,366	0,918	200	7,88
FCFA 54/300EZ	082 101	2,066	1,388	300	11,82
FCFA 54/400EZ	082 201	3,239	2,177	400	15,76
FCFA 54/450EZ	082 251	3,356	2,255	450	17,73
FCFA 54/500EZ	082 301	3,662	2,461	500	19,7
FCFA 54/600EZ	082 401	4,13	2,775	600	23,64

Ref	Matière <i>Raw material</i>	Norme <i>Standard</i>	Finition <i>Coating</i>	Norme <i>Standard</i>
ECLISSE/COUPLER	DC01 C390	EN 10139	Fe/Zn 12/A	EN ISO 2081
ECLISSE DE FOND	DC01 Am	EN 10130	Fe/Zn 12/A	EN ISO 2081

RANGE.

Largeur 50 à 200, éclipse Fascliauto seul.

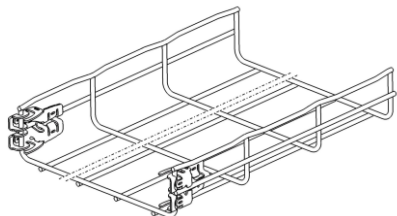

Largeur 300, coupleur Fascliauto + éclipse de fond.

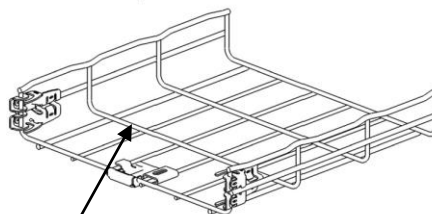

Largeur 400 à 500, coupleur Fascliauto + 2 éclisses de fond

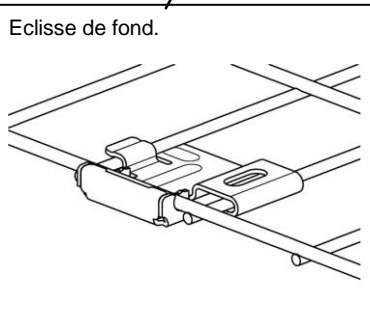
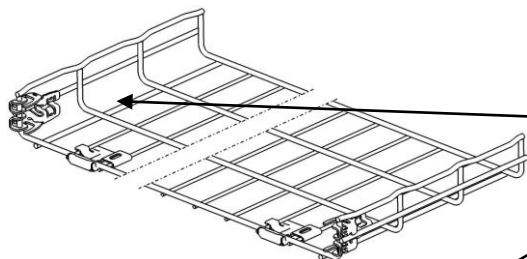

Largeur 600, coupleur Fascliauto + 3 éclisses de fond.

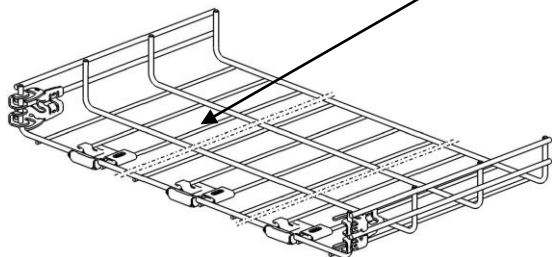

Pour préparer le(s) éclipse(s) de fond avant fixation :

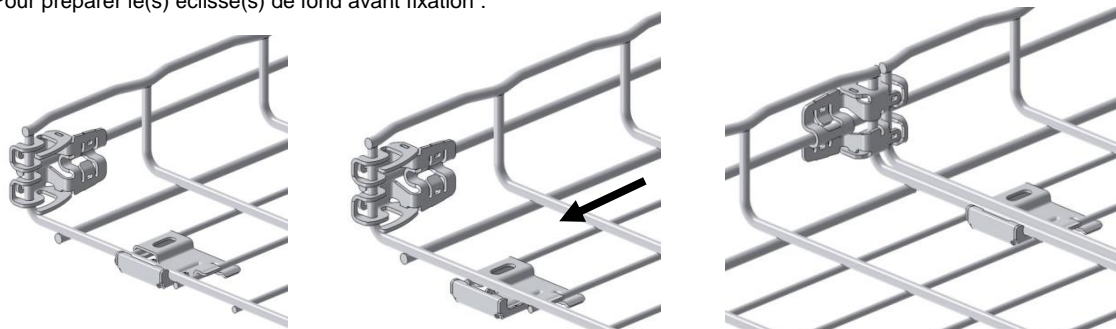

Note :

Largeurs 50 à 200 = distance minimale du mur 10mm.
Largeurs 300 à 600 = distance minimale du mur 13mm.

