

CLOCHE INDUSTRIELLE

HB-100W

CYCLONIC DESIGN

Caracteristiques

Technique

Watt	100W
LED Type	SAMSUNG
Nombre diode LED	168
Efficacité Lumineuse	130lm/W
Flux Sortant	13,000lm(CCT=4000K)±5%
Angle d'éclairage	120°
RA	>85
Durée de vie	100 000 Heures
Garantie	5 ans

Electrique

Driver 1-10v	LIFUD
Input Voltage	AC100-277V
Power Frequency	50/60Hz
Output Voltage	DC80-130V
Power Efficiency	>93%
Power Factor	0.95

Autres

IP & IK	IP67 & IK10
Dissipateur	Aluminum
Lentille	PC
Poids	2.65kg
Dimension	Ø260*H140mm
Poids Net	1.85kg

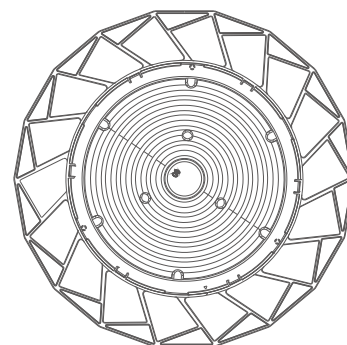
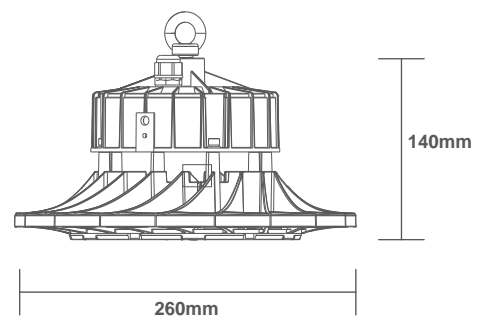

CLOCHE INDUSTRIELLE

HB-150W

CYCLONIC DESIGN

Caracteristiques

Techniques

Watt	150W
LED Type	SAMSUNG
Nombre diode LED	506
Efficacité Lumineuse	130lm/W
Flux Sortant	19,500lm(CCT=4000K) ±5%
Angle d'éclairage	120°
RA	>85
Durée de vie	100 000 Heures
Garantie	5 ans

Électriques

Driver 1-10v	LIFUD
Input Voltage	AC100-277V
Power Frequency	50/60Hz
Output Voltage	DC80-130V
Power Efficiency	>93%
Power Factor	0.95

Autres

IP&IK	IP67 & IK10
Dissipateur	Aluminum
Lentille	PC
Poids	2.98kg
Dimension	Ø260*H140mm
Poids net	2.18kg
Temp. de fonctionnement	- 35° / + 60°

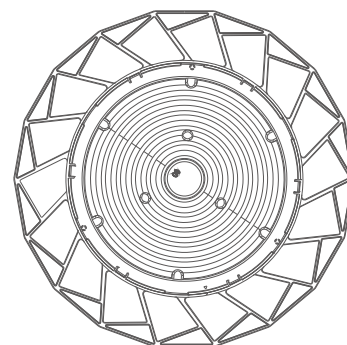
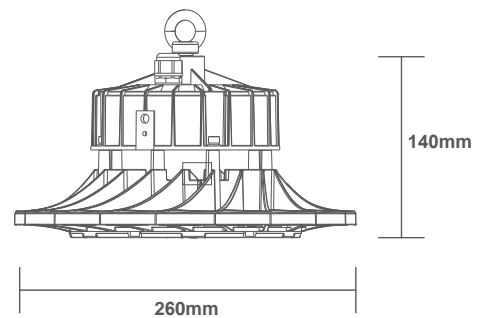

CLOCHE INDUSTRIELLE

HB-200W

CYCLONIC DESIGN

Caracteristiques

Techniques

Watt	200W
LED Type	SAMSUNG
Nombre diode LED	644
Efficacité Lumineuse	130lm/W
Flux Sortant	26,000lm(CCT=4000K) $\pm 5\%$
Angle d'éclairage	120°
RA	>85
Durée de vie	80 000 Heures
Garantie	5 ans

Électriques

Driver 1-10v	LIFUD
Input Voltage	AC100-277V
Power Frequency	50/60Hz
Output Voltage	DC80-130V
Power Efficiency	>93%
Power Factor	0.95

Autres

IP&IK	IP67 & IK10
Dissipateur	Aluminum
Lentille	PC
Gross Weight	4.00kg
Dimension	Ø280*H150mm
Poids	3.20kg
Temp. de fonctionnement	- 35° / + 60°

