

TE P31 TEP H50 100 à 500
PERFORATED T-PIECE P31 50x100 to 500

GC
HDG

legrand® | CABLE
MANAGEMENT

FT0763-3

11 13

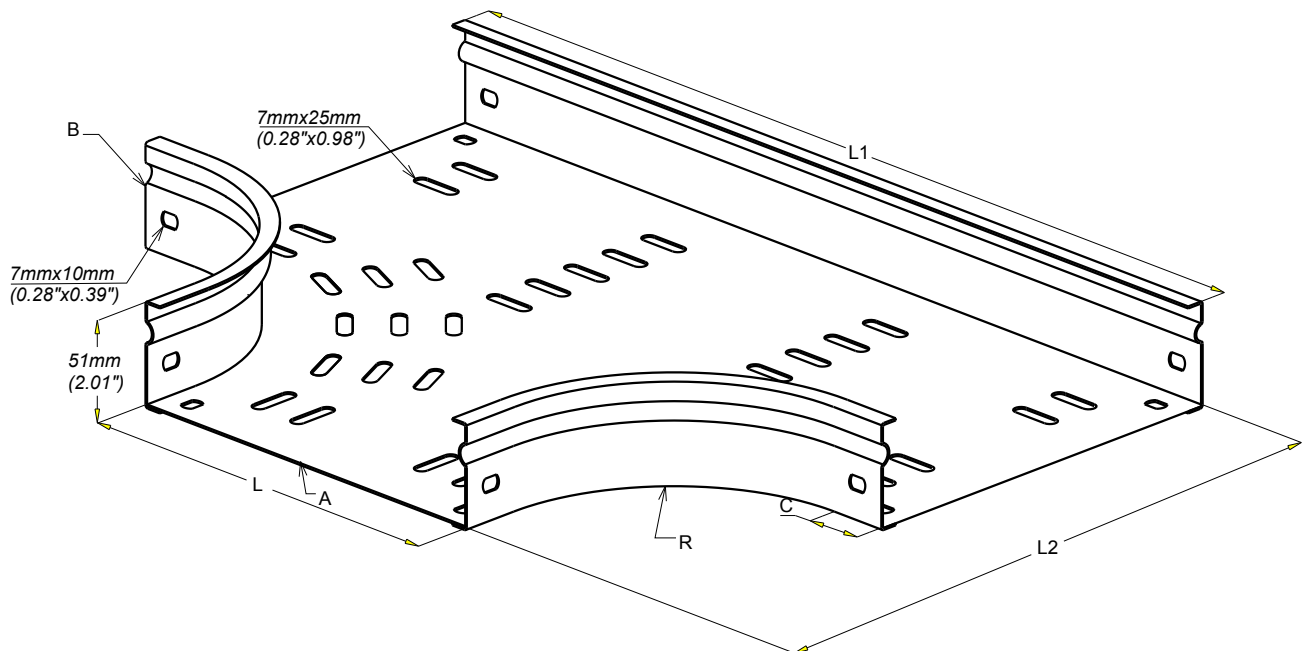

REF	CODE	L /L (mm) (inch)	A /A (mm) (inch)	B /B (mm) (inch)	C /C (mm) (inch)	R /R (mm) (inch)	L1 /L1 (mm) (inch)	L2 /L2 (mm) (inch)
P31 TEP 50x100	343 454	100 (3.94")	0.8 (0.032")	1 (0.039")	30 (1.18")	100 (3.94")	358 (14.11")	229 (9.02")
P31 TEP 50x150	343 455	150 (5.91")	0.8 (0.032")	1 (0.039")	30 (1.18")	100 (3.94")	408 (16.08")	279 (10.99")
P31 TEP 50x200	343 456	200 (7.87")	0.8 (0.032")	1 (0.039")	30 (1.18")	100 (3.94")	458 (18.05")	329 (12.96")
P31 TEP 50x300	343 457	300 (11.81")	1 (0.039")	1 (0.039")	30 (1.18")	100 (3.94")	558 (21.99")	429 (16.90")
P31 TEP 50x400	343 458	400 (15.75")	1 (0.039")	1 (0.039")	50 (1.97")	150 (5.91")	798 (31.44")	599 (23.60")
P31 TEP 50x500	343 459	500 (19.69")	1 (0.039")	1 (0.039")	50 (1.97")	150 (5.91")	898 (35.38")	699 (27.54")

NORMES/STANDARD

MATIERE / MATERIAL
S 235 JR
PROTECTION / COATING
GC/HDG

EN 10 025

EN ISO 1461

Propriété exclusive de LEGRAND, ne peut être ni copié, ni transmis à des tiers sans autorisation écrite.

Exclusive property of LEGRAND shouldn't be reproduced or transmitted to any people

without written authorization