

CROIX P31 XP H50 100 à 500  
PERFORATED CROSS P31 50x100 to 500

GC  
HDG

**legrand** | CABLE  
MANAGEMENT

FT0767-3

11 13

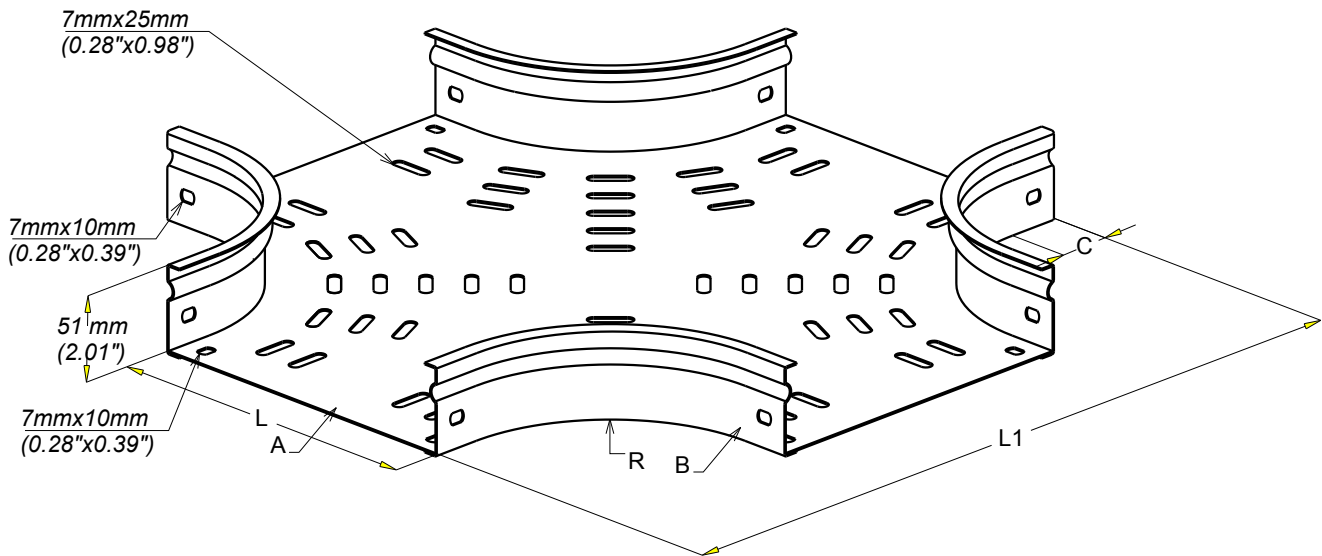

REF	CODE	L /L (mm) (inch)	A /A (mm) (inch)	B /B (mm) (inch)	C /C (mm) (inch)	R /R (mm) (inch)	L1 /L1 (mm) (inch)
P31 XP 50x100	343 480	100 (3.94")	0.8 (0.032")	1 (0.039")	30 (1.18")	100 (3.94")	358 (14.11")
P31 XP 50x150	343 481	150 (5.91")	0.8 (0.032")	1 (0.039")	30 (1.18")	100 (3.94")	408 (16.08")
P31 XP 50x200	343 482	200 (5.91")	0.8 (0.032")	1 (0.039")	30 (1.18")	100 (3.94")	458 (18.05")
P31 XP 50x300	343 483	300 (7.87")	1 (0.039")	1 (0.039")	30 (1.18")	100 (3.94")	558 (21.99")
P31 XP 50x400	343 484	400 (11.81")	1 (0.039")	1 (0.039")	50 (1.97")	150 (5.91")	798 (31.44")
P31 XP 50x500	343 485	500 (19.69")	1 (0.039")	1 (0.039")	50 (1.97")	150 (5.91")	898 (35.38")

NORMES/STANDARD

MATIERE / MATERIAL  
S 235 JR

EN 10 025

PROTECTION / COATING  
GC/HDG

EN ISO 1461

Propriété exclusive de LEGRAND, ne peut être ni copié, ni transmis à des tiers sans autorisation écrite.

Exclusive property of LEGRAND shouldn't be reproduced or transmitted to any people

without written authorization