

P31 Branch H100 HDG

Reference(s) : 347 772 to 778

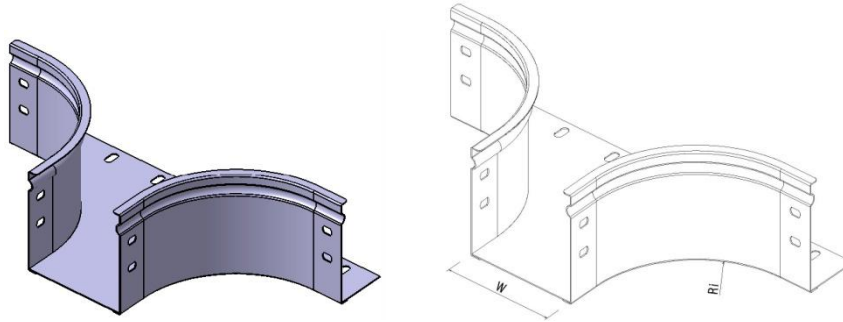

Ref.	Description	Raw Material (R.M.)	R.M. Standard	Coating Standard	W (mm)	Ri (mm)	Thickness (mm)	Weight (kg)
347 772	Branch P31 H100 HDG W100	DX51D Z275 (RE MIN 220 MPA)	EN10346	ISO1461	100	100	1	1
347 773	Branch P31 H100 HDG W150	DX51D Z275 (RE MIN 220 MPA)	EN10346	ISO1461	150	100	1	1.1
347 774	Branch P31 H100 HDG W200	DX51D Z275 (RE MIN 220 MPA)	EN10346	ISO1461	200	100	1	1.2
347 775	Branch P31 H100 HDG W300	DX51D Z275 (RE MIN 220 MPA)	EN10346	ISO1461	300	100	1	1.5
347 776	Branch P31 H100 HDG W400	DX51D Z275 (RE MIN 220 MPA)	EN10346	ISO1461	400	150	1	2.5
347 777	Branch P31 H100 HDG W500	DX51D Z275 (RE MIN 220 MPA)	EN10346	ISO1461	500	150	1	2.8
347 778	Branch P31 H100 HDG W600	DX51D Z275 (RE MIN 220 MPA)	EN10346	ISO1461	600	150	1	3.2