

03904

Prisma Plus

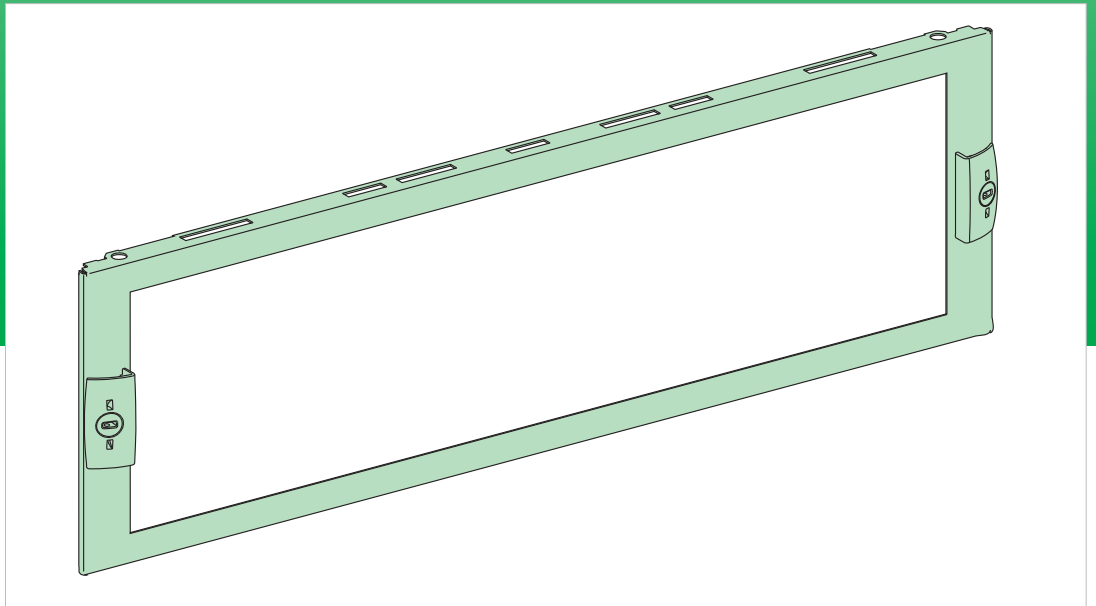

A

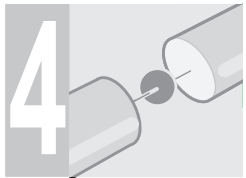
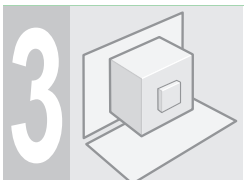
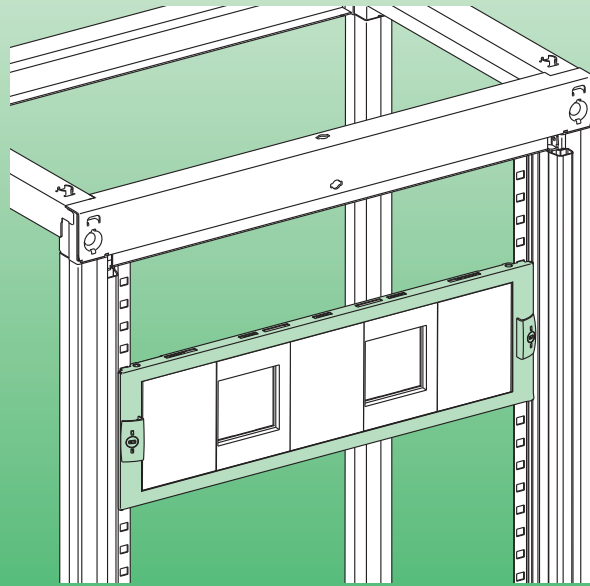
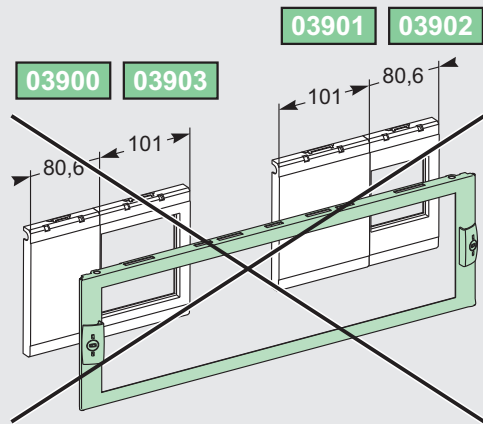
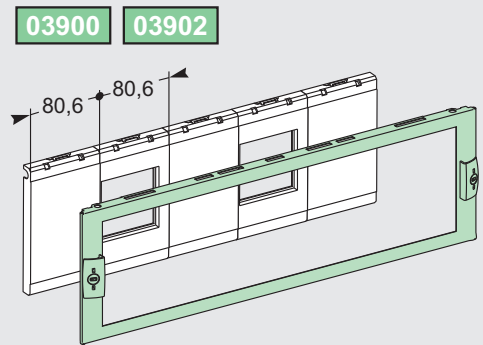
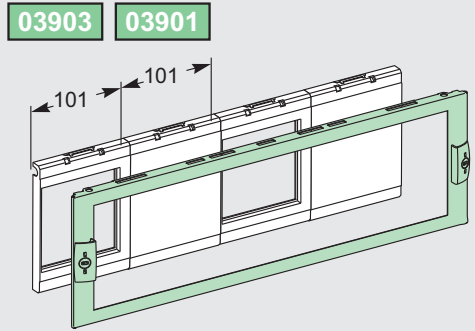
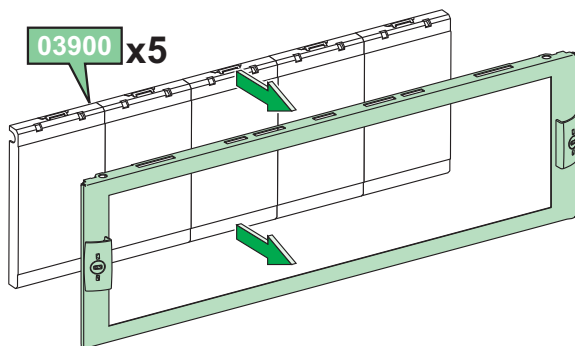
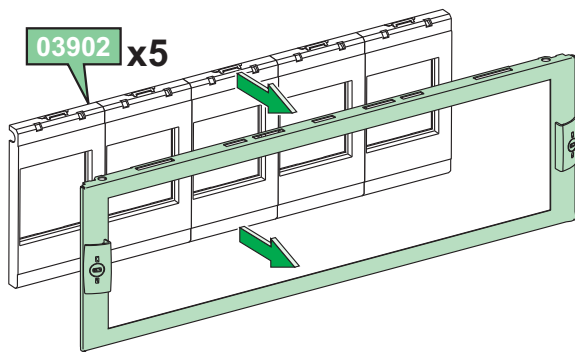
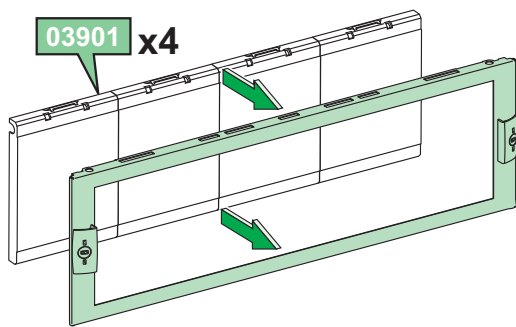
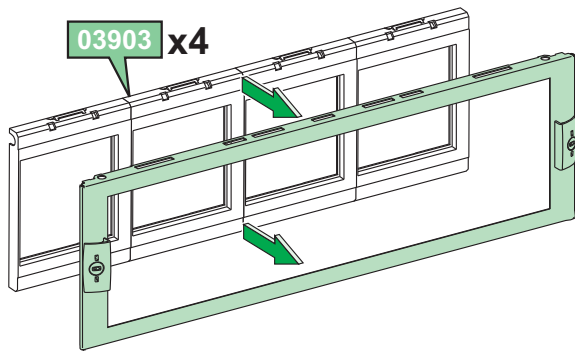

03901

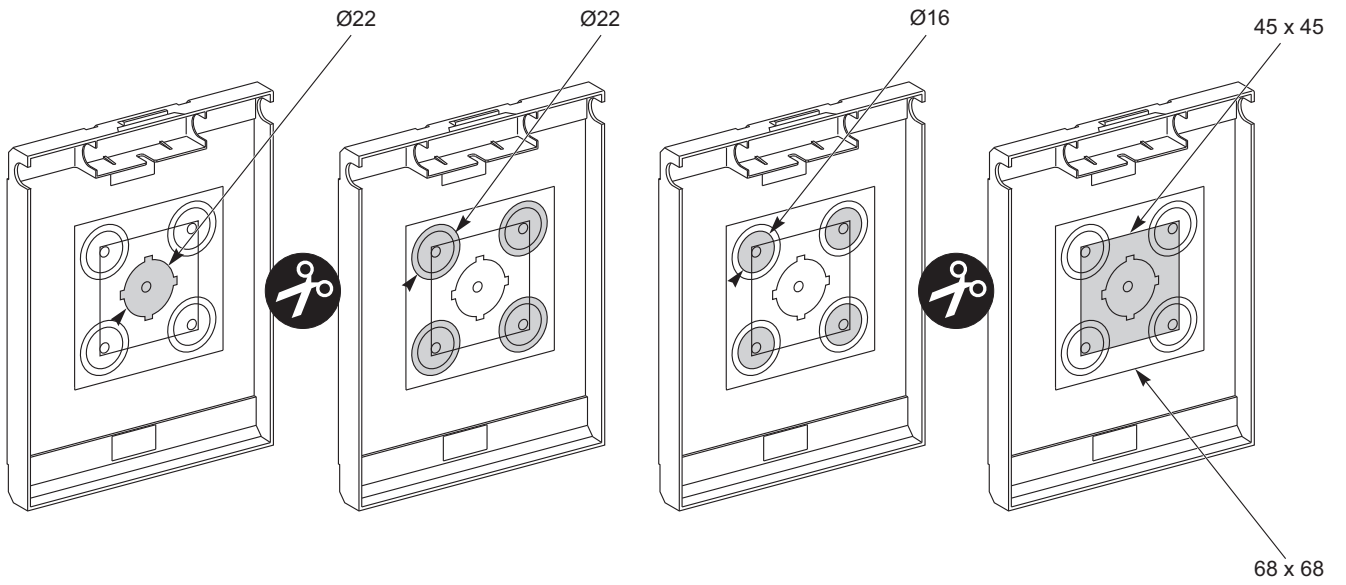

03900

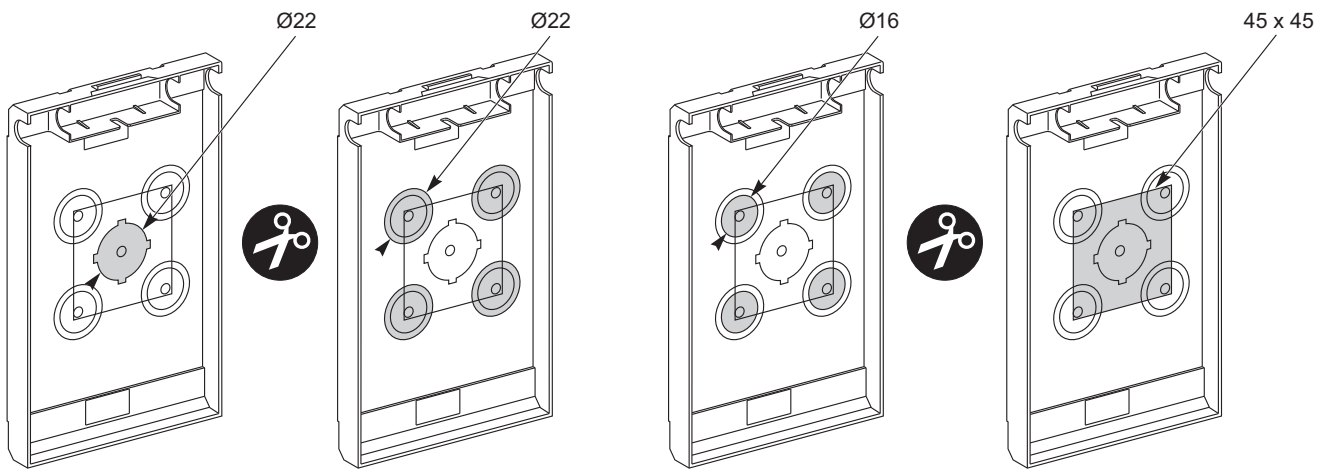

03903

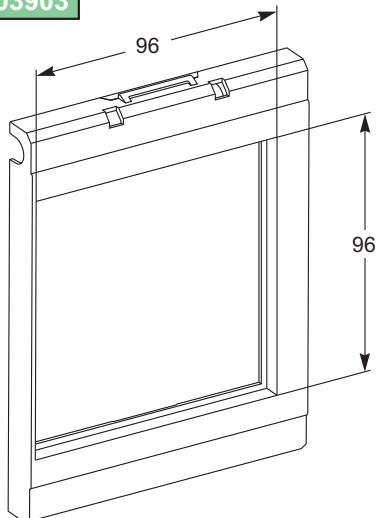

03902

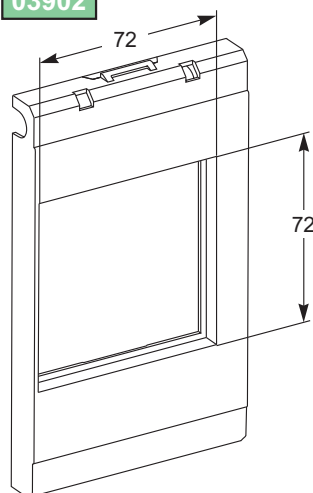

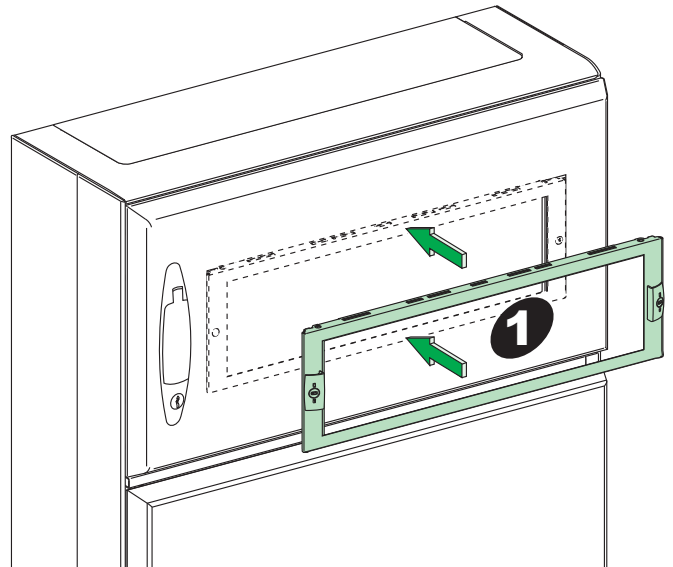
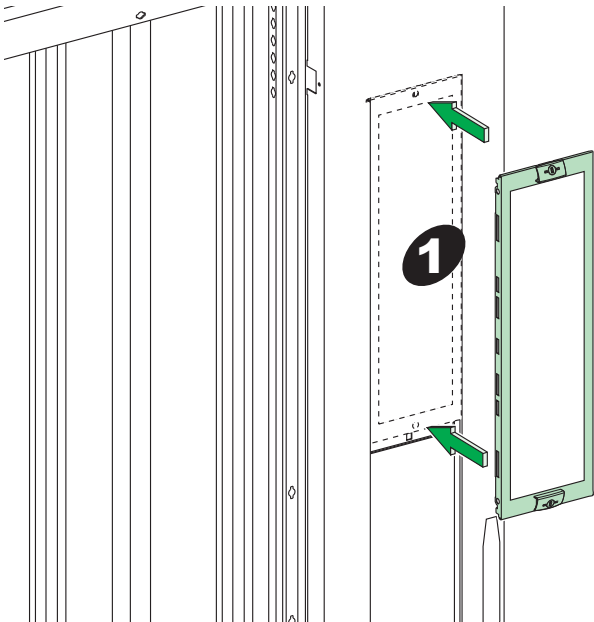
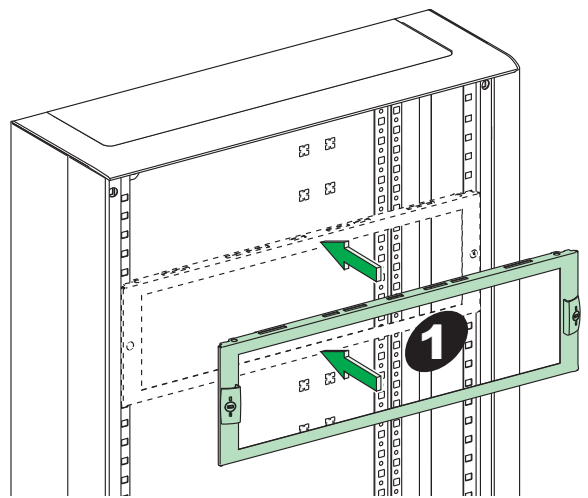
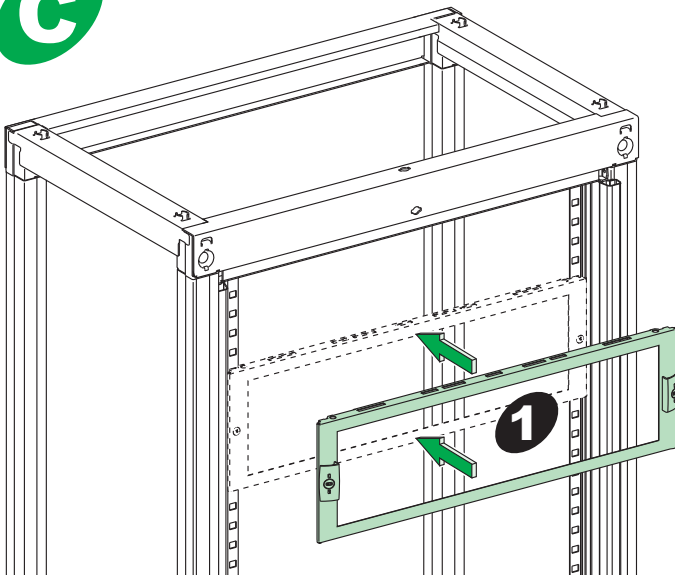
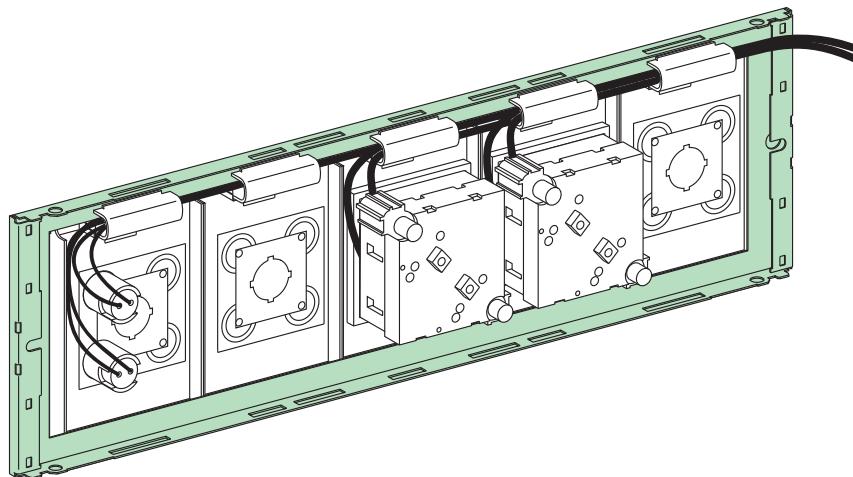
C**D****Schneider Electric Industries SAS**

35, rue Joseph Monier
CS 30323
F - 92506 Rueil Malmaison Cedex

RCS Nanterre 954 503 439
Capital social 896 313 776 €
www.schneider-electric.com

04696186 AB 00

En raison de l'évolution des normes et du matériel, les caractéristiques indiquées par le texte et les images de ce document ne nous engageant qu'après confirmation par nos services.

As standards, specifications and designs change from time to time, please ask for confirmation of the information given in this publication.

Publication : Schneider Electric
Réalisation : Ameg
Impression : Coquand
Format de pliage : 105 x 297 mm



Ce document a été imprimé sur du papier écologique.
This document has been printed on ecological paper.

03/2009