

MasterPact NW

- FR Notice d'installation
- EN Installation manual
- DE Montageanleitung
- IT Manuale d'installazione
- ES Instrucciones de instalación

Verrouillage d'embranchage porte ouverte
Racking interlock
Verriegelung der Kurbeinführung
Blocco inserzione a porta aperta
Enclavamiento de enchufado puerta abierta

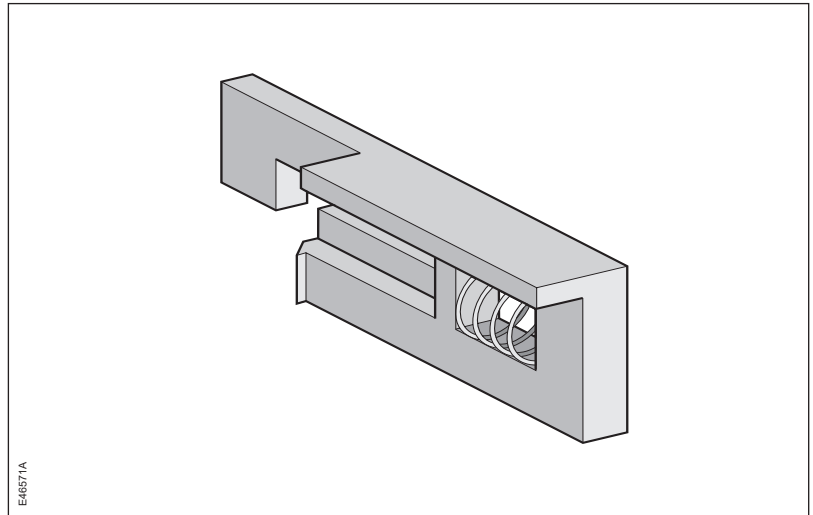

Avis de non-responsabilité / Disclaimer / Haftungsausschluss / Rinuncia di responsabilità / Exención de responsabilidad

<p>REMARQUE IMPORTANTE</p> <ul style="list-style-type: none"> ■ L'installation, l'utilisation, la réparation et la maintenance des équipements électriques doivent être assurées par du personnel qualifié uniquement. ■ Schneider Electric décline toute responsabilité quant aux conséquences de l'utilisation de ce matériel. 	<p>PLEASE NOTE</p> <ul style="list-style-type: none"> ■ Electrical equipment should be installed, operated, serviced, and maintained only by qualified personnel. ■ No responsibility is assumed by Schneider Electric for any consequences arising out of the use of this material. 	<p>BITTE BEACHTEN</p> <ul style="list-style-type: none"> ■ Elektrische Geräte dürfen nur von Fachpersonal installiert, betrieben, bedient und gewartet werden. ■ Schneider Electric haftet nicht für Schäden, die durch die Verwendung dieses Materials entstehen. 	<p>NOTA</p> <ul style="list-style-type: none"> ■ Manutenzione, riparazione, installazione e uso delle apparecchiature elettriche si devono affidare solo a personale qualificato. ■ Schneider Electric non si assume alcuna responsabilità per qualsiasi conseguenza derivante dall'uso di questi prodotti. 	<p>TENGA EN CUENTA</p> <ul style="list-style-type: none"> ■ La instalación, manejo, puesta en servicio y mantenimiento de equipos eléctricos deberán ser realizados sólo por personal cualificado. ■ Schneider Electric no se hace responsable de ninguna de las consecuencias del uso de este material.
---	---	---	--	---

Consignes de sécurité / Safety instructions / Sicherheitshinweise / Informazioni di sicurezza / Información de seguridad

 DANGER / DANGER / GEFAHR / PERICOLO / PELIGRO				
<p>RISQUE D'ÉLECTROCUTION, D'EXPLOSION OU D'ÉCLAIR D'ARC ÉLECTRIQUE</p> <ul style="list-style-type: none"> ■ Portez un équipement de protection personnelle adapté et respectez les consignes de sécurité électrique courantes. Reportez-vous aux normes NFPA 70E, CSA Z462 ou aux textes équivalents applicables dans votre région du monde. ■ Seul un personnel qualifié doit effectuer l'installation et l'entretien de cet appareil. ■ Débranchez toutes les sources d'alimentation de cet équipement avant d'effectuer toute opération interne ou externe sur celui-ci. Verrouillez l'appareillage en position isolée. ■ Utilisez toujours un dispositif de détection de tension ayant une valeur nominale appropriée pour vous assurer que l'alimentation est coupée. ■ Installez des barrières de sécurité et affichez un signal de danger. ■ Remettez en place tous les équipements, les portes et les capots avant de remettre l'appareil sous tension. <p>Si ces directives ne sont pas respectées, cela entraînera la mort ou des blessures graves.</p>	<p>HAZARD OF ELECTRIC SHOCK, EXPLOSION OR ARC FLASH</p> <ul style="list-style-type: none"> ■ Apply appropriate personal protective equipment (PPE) and follow safe electrical work practices. See NFPA 70E, CSA Z462 or local equivalent. ■ This equipment must only be installed and serviced by qualified electrical personnel. ■ Turn off all power supplying this equipment before working on or inside equipment. Lock the switchgear in the isolated position. ■ Always use a properly rated voltage sensing device to confirm power is off. ■ Install safety barriers and display a danger sign. ■ Replace all devices, doors, and covers before turning on power to this equipment. <p>Failure to follow these instructions will result in death or serious injury.</p>	<p>GEFAHR VON ELEKTRISCHEM SCHLAG, EXPLOSION ODER LICHTBOGEN</p> <ul style="list-style-type: none"> ■ Tragen Sie persönliche Schutzausrüstung (PSA) und befolgen Sie sichere Verfahren im Umgang mit Elektrogeräten. Siehe NFPA 70E, CSA Z462 oder lokale Entsprechung. ■ Diese Geräte dürfen nur von qualifizierten Elektrikern installiert und gewartet werden. ■ Schalten Sie vor Arbeiten am bzw. im Innern des Geräts die gesamte Spannungsversorgung ab. Die Schaltanlage in die Trennstellung bringen. ■ Verwenden Sie für die Prüfung vorhandener Spannung stets einen Spannungsfühler mit zutreffender Bemessungsspannung. ■ Bringen Sie Sicherheitsbarrieren und einen Warnhinweis an. ■ Bringen Sie alle Vorrichtungen, Türen und Abdeckungen wieder an, bevor Sie das Gerät einschalten. <p>Die Nichtbeachtung dieser Anweisungen führt zu Tod oder schweren Verletzungen.</p>	<p>RISCHIO DI FOLGORAZIONE, ESPLOSIONE O BAGLIORI DA ARCO</p> <ul style="list-style-type: none"> ■ Utilizzare dispositivi di protezione individuale (DPI) idonei e adottare misure di sicurezza adeguate per lavori elettrici. Vedere le normative NFPA 70E, CSA Z462 o le norme equivalenti nel paese di installazione. ■ Installazione e manutenzione di questa apparecchiatura si devono affidare solo ad elettricisti qualificati. ■ Prima di lavorare con l'apparecchiatura o al suo interno isolare completamente l'alimentazione elettrica. Bloccare l'interruttore in posizione isolata. ■ Per verificare che l'alimentazione sia isolata usare sempre un rilevatore di tensione correttamente tarato. ■ Installare barriere di sicurezza e apporre un segnale di pericolo. ■ Sostituire dispositivi, sportelli e coperture prima di riaccendere l'alimentazione. <p>Il mancato rispetto di queste istruzioni provocherà morte o gravi infortuni.</p>	<p>PELIGRO DE DESCARGA ELÉCTRICA, EXPLOSIÓN O ARCO ELÉCTRICO</p> <ul style="list-style-type: none"> ■ Utilice el equipo de protección personal (PPE) adecuado y siga las recomendaciones para el trabajo seguro con dispositivos eléctricos. Consulte NFPA 70E, CSA Z462 o la norma local equivalente. ■ Solo el personal de electricidad cualificado podrá instalar, programar y realizar el mantenimiento del equipo. ■ Desconecte toda la alimentación de este equipo antes de trabajar en él o en su interior. Bloquee la aparatadura eléctrica en la posición de aislamiento. ■ Utilice siempre un dispositivo de detección de tensión de capacidad adecuada para confirmar la ausencia de alimentación eléctrica. ■ Instale barreras de seguridad y coloque un cartel de peligro. ■ Vuelva a colocar todos los dispositivos, las puertas y las tapas antes de conectar la alimentación de este equipo. <p>El incumplimiento de estas instrucciones podrá causar la muerte o lesiones serias.</p>

Avant toute intervention sur l'appareil / Before working on the device / Vor jeglichem Eingriff an dem Gerät / Prima di qualsiasi intervento sull'apparecchio / Antes de cualquier intervención sobre el aparato

Disjoncteur débrochable / Drawout circuit breaker / Leistungsschalter in Einschubtechnik / Interruttore estraibile / Interruptor automático seccionable

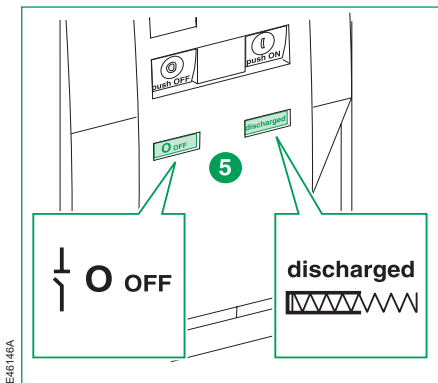
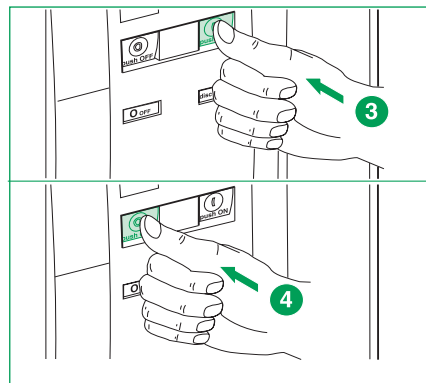
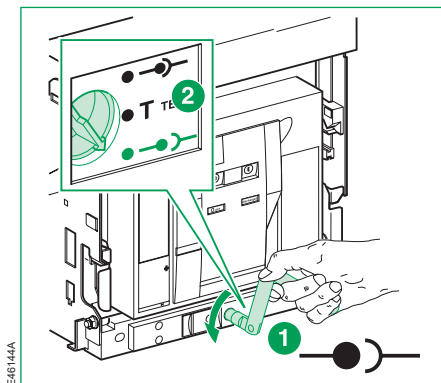

Installation / Installation / Installation / Installazione / Instalación

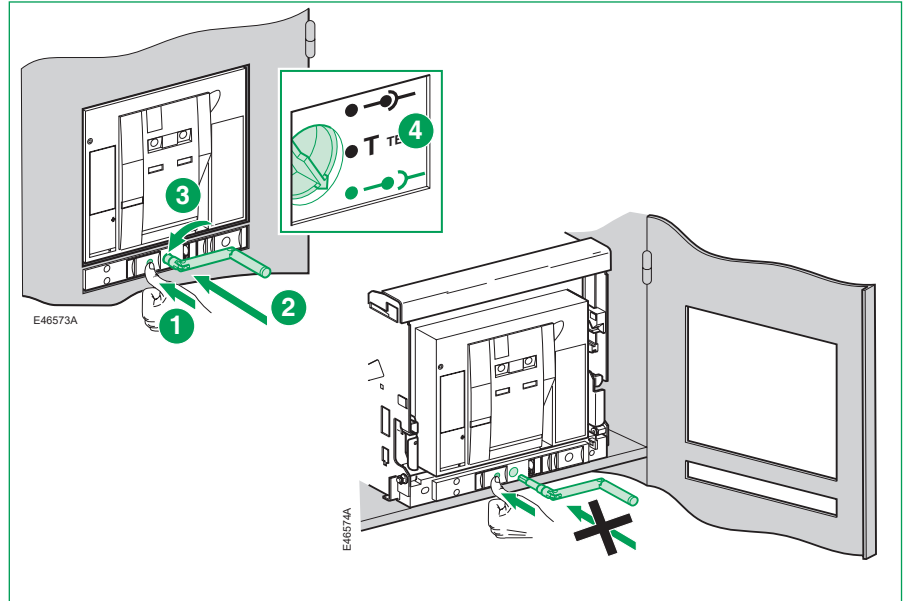
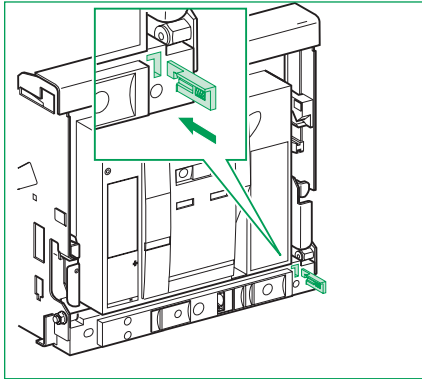

Schneider Electric Industries SAS
35 rue Joseph Monier
CS 30323
F - 92506 Rueil Malmaison Cedex
www.se.com

 Printed on recycled paper.

Designed by: Schneider Electric
Printed by: