

xStorage Hybrid system

xStorage Hybrid Single Phase Inverter



EATON

Powering Business Worldwide

DISCLAIMER OF WARRANTIES AND LIMITATION OF LIABILITY

The information, recommendations, descriptions and safety notations in this document are based on Eaton Corporation's ("Eaton") experience and judgment and may not cover all contingencies. If further information is required, an Eaton sales office should be consulted. Sale of the product shown in this literature is subject to the terms and conditions outlined in appropriate Eaton selling policies or other contractual agreement between Eaton and the purchaser.

THERE ARE NO UNDERSTANDINGS, AGREEMENTS, WARRANTIES, EXPRESSED OR IMPLIED, INCLUDING WARRANTIES OF FITNESS FOR A PARTICULAR PURPOSE OR MERCHANTABILITY, OTHER THAN THOSE SPECIFICALLY SET OUT IN ANY EXISTING CONTRACT BETWEEN THE PARTIES. ANY SUCH CONTRACT STATES THE ENTIRE OBLIGATION OF EATON. THE CONTENTS OF THIS DOCUMENT SHALL NOT BECOME PART OF OR MODIFY ANY CONTRACT BETWEEN THE PARTIES.

In no event will Eaton be responsible to the purchaser or user in contract, in tort (including negligence), strict liability or other-wise for any special, indirect, incidental or consequential damage or loss whatsoever, including but not limited to damage or loss of use of equipment, plant or power system, cost of capital, loss of power, additional expenses in the use of existing power facilities, or claims against the purchaser or user by its customers resulting from the use of the information, recommendations and descriptions contained herein. The information contained in this manual is subject to change without notice.

Content overview

1. INTRODUCTION	6
1.1 System Introduction	6
1.2 Operation Modes	6
1.3 Safety Introduction	8
1.3.1 Operator Requirements	8
1.3.2 Protection of Warning Sign	8
1.3.3 Setting of Warning Sign for Safety	8
1.3.4 Measuring Equipment	8
1.3.5 Moisture Protection	8
1.3.6 Operation after Power Failure	8
1.3.7 Hazard Information	9
1.3.8 Safety Datasheet	9
1.4 General Precautions	10
1.5 Parts List	11
1.6 System Appearance	15
1.6.1 Cable Box Part	16
1.7 Liability Limitation	17
3. SYSTEM OPERATION	18
3.1 Switch On	18
3.2 Switch Off	19
3.3 Emergency Procedure	19
3.3.1 Emergency Handling Plan	19
3.3.2 Hazards	19
3.3.3 Fire	19
4. EMS INTRODUCTION AND SET UP	20
4.1 Function Description	20
6. STICK LOGGER USAGE	21
6.4 Usage Methods and Notices for Reset Button	21
8. FAULT DIAGNOSIS AND SOLUTIONS	22
10. ROUTINE MAINTENANCE	24
10.1 Maintenance Plan	24
10.1.1 Operating Environment	24
10.1.2 Equipment Cleaning	24
10.1.3 Cable, Terminal, and Equipment Inspection	24
10.2 Notes	24
11. QUALITY ASSURANCE	25

1. Introduction

1.1 System Introduction

This manual is intended for end-users of xStorage Hybrid single phase inverters. It describes the operating environment, the product and its operating behavior. The document does not cover installation and uninstallation, commissioning guidance and troubleshooting.

Table 1. System components

1.2 Operation Modes

There are three basic modes that end users can choose via inverter screen/APP.

SELF CONSUME: The energy generated by the solar panels will be used in the following order: Feed the home loads; Charge the battery and then, feed into the grid.

When the sun is off, the load will be supported by battery to enhance self-consumption.

If the power supply from the batteries is not sufficient, the grid will support the load demand.

Figure 1. Self-consume operation mode

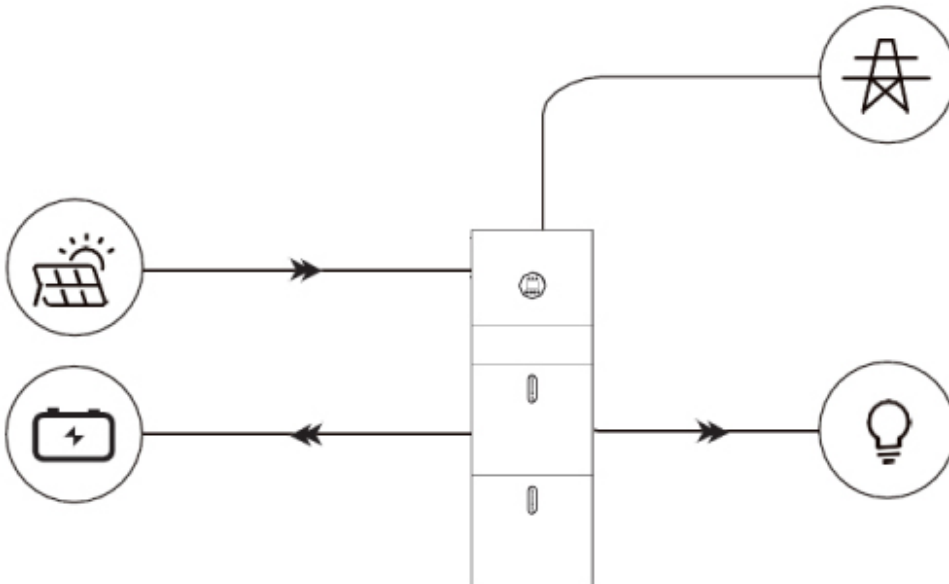

BAT PRIORITY: Under this mode, the battery is only used as a backup power supply when the grid fails and as long as the grid works, the batteries won't be used to power the loads. The battery will get charged with the power generated by the PV system or from the grid.

Figure 2. Battery priority operation mode

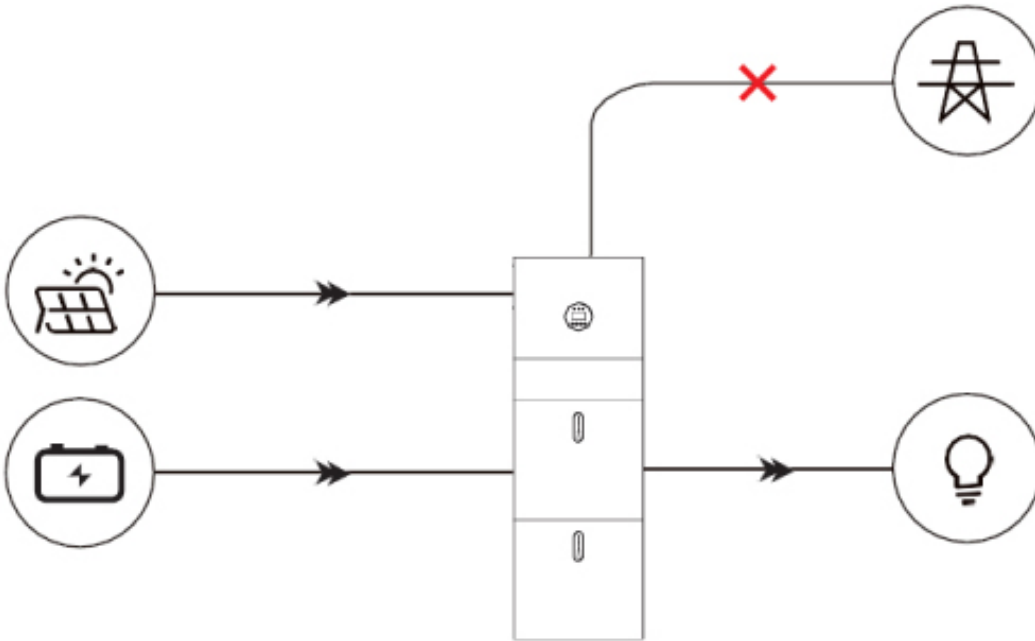

PEAK SHIFT: This mode is designed for time-use mode customer. The customer is able to set up the charging/discharging time & power via inverter screen or APP.

Figure 3. Peak shift operation mode

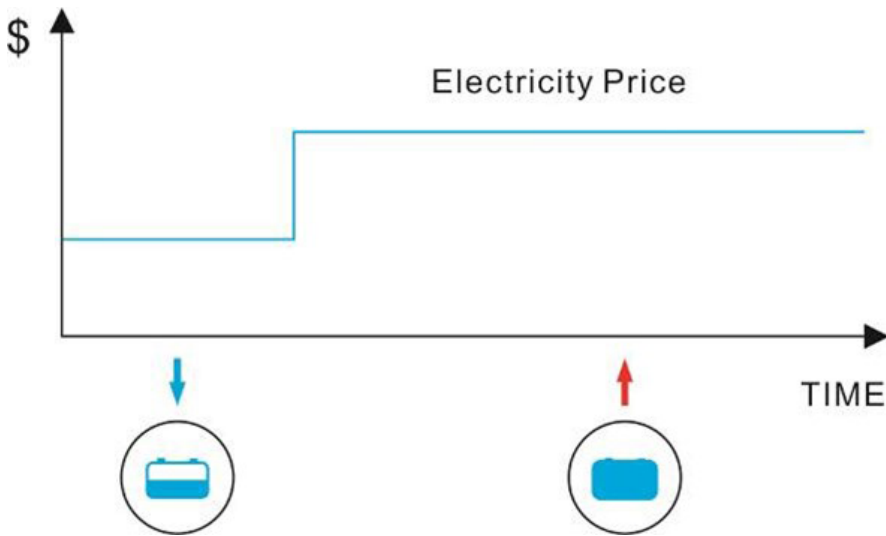

1.3 Safety Introduction

1.3.1 Operator Requirements

The operators require a professional qualification or training.

The operators should be familiar with the whole storage system, including compositions and working principles of the system.

The operators should be familiar with the Product Instruction.

While maintaining, the maintainer is not allowed to operate any equipment until all the equipment has been turned off and fully discharged.

1.3.2 Protection of Warning Sign

The warning signs contain important information for the system to operate safely, and it is strictly prohibited to torn or damage them. Ensure that the warning signs are always well-functioned and correct placed. The signs must be replaced immediately when damaged.



This sign indicates a hazardous situation which, if not avoided, could result in death or serious injury!

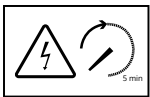

The XSTHS1P-3.68K, XSTHS1P-5K, XSTHS1P-6K must not be touched or put into service until 5 minutes after it has been switched off or disconnected to prevent an electric shock or injury.



This sign shows danger of hot surface!



Refer to the operating instructions.

1.3.3 Setting of Warning Sign for Safety

During instruction, maintenance, and repair, follow the instructions below to prevent non-specialist personnel from causing misuse or accident:

- Obvious signs should be placed at front switch and rear-level switch to prevent accidents caused by false switching.
- Warning signs or tapes should be set near operating areas.
- The system must be reinstalled after maintenance or operation.

1.3.4 Measuring Equipment

To ensure the electrical parameters to match requirements, related measuring equipment are required when the system is being connected or tested. Ensure that the connection and use matched specification to prevent electric arcs or shocks.

1.3.5 Moisture Protection

It is very likely that moisture may cause damages to the system. Repair or maintaining activities in wet weather should be avoided or limited.

1.3.6 Operation after Power Failure

The battery system is part of the energy storage system which stores life-threatening high voltage even when the DC side is switched off. Touching the battery outlets is strictly prohibited. The inverter can keep a life-threatening voltage even after disconnecting it from the DC and / or AC side. Therefore, for safety reasons, it must be tested with a properly calibrated voltage tester before an installer works on the equipment.

1.3.7 Hazard Information

Classification of the hazardous chemical

Exempt from classification according to Australian WHS regulations.

Other hazards

This product is a Lithium Iron Phosphate Battery with certified compliance under the UN Recommendations on Transport of Dangerous Goods, Manual of Tests and Criteria, Part III, subsection 38.3. For the battery cell, chemical materials are stored in a hermetically sealed metal case, designed to withstand temperatures and pressures encountered during normal use. As a result, during normal use, there is no physical danger of ignition or explosion and chemical danger of hazardous materials' leakage. However, if the product is exposed to a fire, added mechanical shocks, decomposed, added electric stress by misuse, the gas release vent will be operated. The battery cell case will be breached at the extreme. Hazardous materials may be released. Moreover, if heated strongly by the surrounding fire, acrid or harmful fume may be emitted.

1.3.8 Safety Datasheet

For detailed information please refer to the provided battery safety datasheet.

1.4 General Precautions



DANGER

Danger to life due to high voltages of the PV array, battery and electric shock. When exposed to sunlight, the PV array generates dangerous DC voltage which will be present in the DC conductors and the live components of the inverter. Touching the DC conductors or the live components can lead to lethal electric shocks. If you disconnect the DC connectors from the system under load, an electric arc may occur leading to electric shock and burns.

- Do not touch uninsulated cable ends. Do not touch the DC
- Do not open the inverter and battery.
- Do not wipe the system with damp cloth.
- Have the system installed and commissioned by qualified people with the appropriate skills only.
- Prior to performing any work on the inverter or the battery pack, disconnect the inverter from all voltage sources as described in this document.



WARNING

Risk of chemical burns from electrolyte or toxic gases. During standard operation, no electrolyte shall leak from the battery pack and no toxic gases shall form. Despite careful construction, if the Battery Pack is damaged or a fault occurs, it is possible that electrolyte may be leaked or toxic gases formed.

- Do not install the system in any environment of temperature below -10°C or over 50°C and in which humidity is over 95%.
- Do not touch the system with wet hands.
- Do not put any heavy objects on top of the system.
- Do not damage the system with sharp objects.
- Do not install or operate the system in potentially explosive atmospheres or areas of high humidity.
- Do not mount the inverter and the battery pack in areas containing highly flammable materials or gases.
- If moisture has penetrated the system (e.g. due to a damaged enclosure), do not install or operate the system.
- Do not move the system when it is already connected with battery modules. Secure the system to prevent tipping with restraining straps in your vehicle.
- The transportation of XSTHS1P-3.68K, XSTHS1P-5K, XSTHS1P-6K must be made by the manufacturer or an authorized people. These instructions shall be recorded and repeated.
- A certified ABC fire extinguisher with minimum capacity of 2kg must be carried along when transporting.
- It is totally prohibited to smoke in the vehicle as well as close to the vehicle when loading and unloading.
- For the exchange of a battery module, please request for new hazardous goods packaging if needed, pack it and let it be picked up by the suppliers.
- In case of contact with electrolyte, rinse the affected areas immediately with water and consult a doctor without delay.



CAUTION

Risk of injury through lifting or dropping the system. The inverter and battery are heavy. There is risk of injury if the inverter or battery is lifted incorrectly or dropped during transport or when attaching to or removing from the wall.

- Lifting and transporting the inverter and battery must be carried out by more than 2 people.











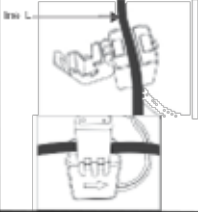

1.5 Parts List

Check the following parts list to ensure it is complete.

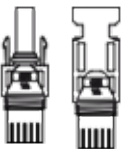
Delivers a total system separately on site to client, this consists of:





Inverter

Figure 4. Inverter box content

					
6×M5*12	5×ST6.3*50	5×D10*50	2×CT Connector	1x CT and com cable	2×AC Collector
					
4×MC4	1×Collector	1×Mounting Panel	5×M6 Gasket	1×COM Connector	1×User Manual

PACK5.1

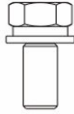
Figure 5. Mounting panel box content

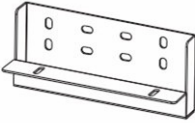
			
4×ST6.3*50	4×D10*50	2×M5*12	4×M6 Gasket
			
1×Mounting Panel			

Accessory - Cable (PACK5.1)

Figure 6. Accessory cables 1

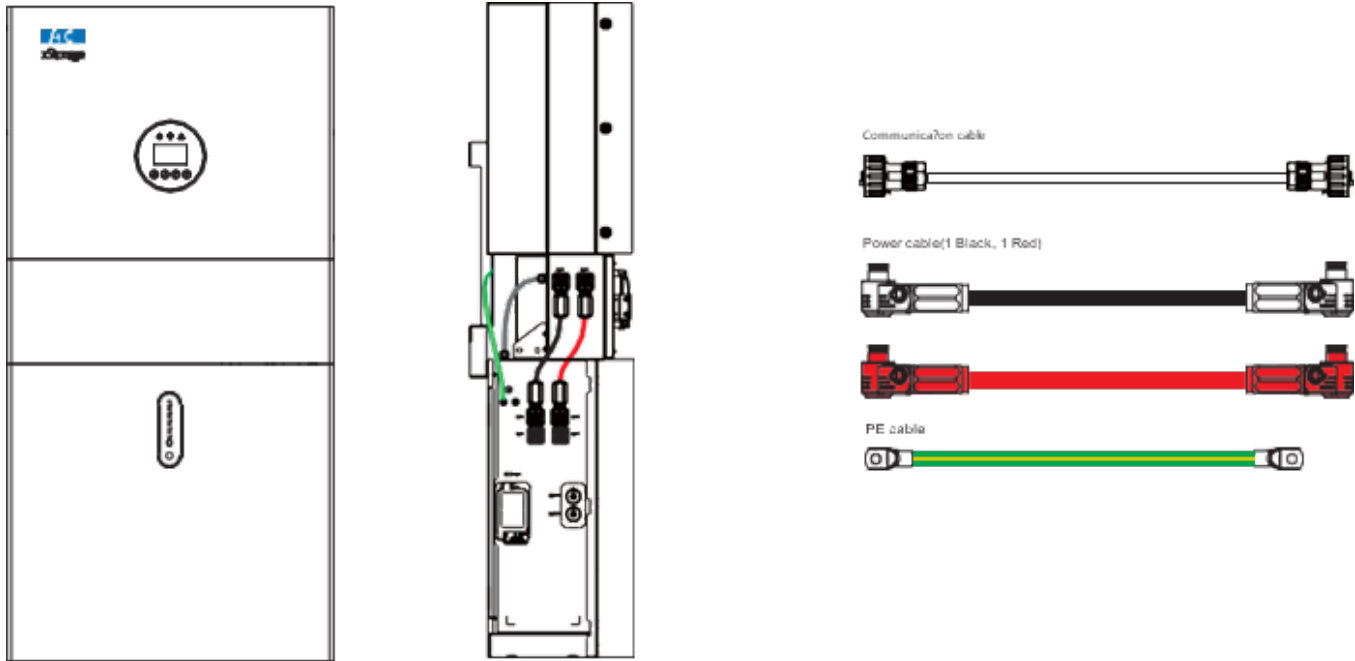

Accessory - Cable (PACK10.2)

Figure 7. Accessory cables 2

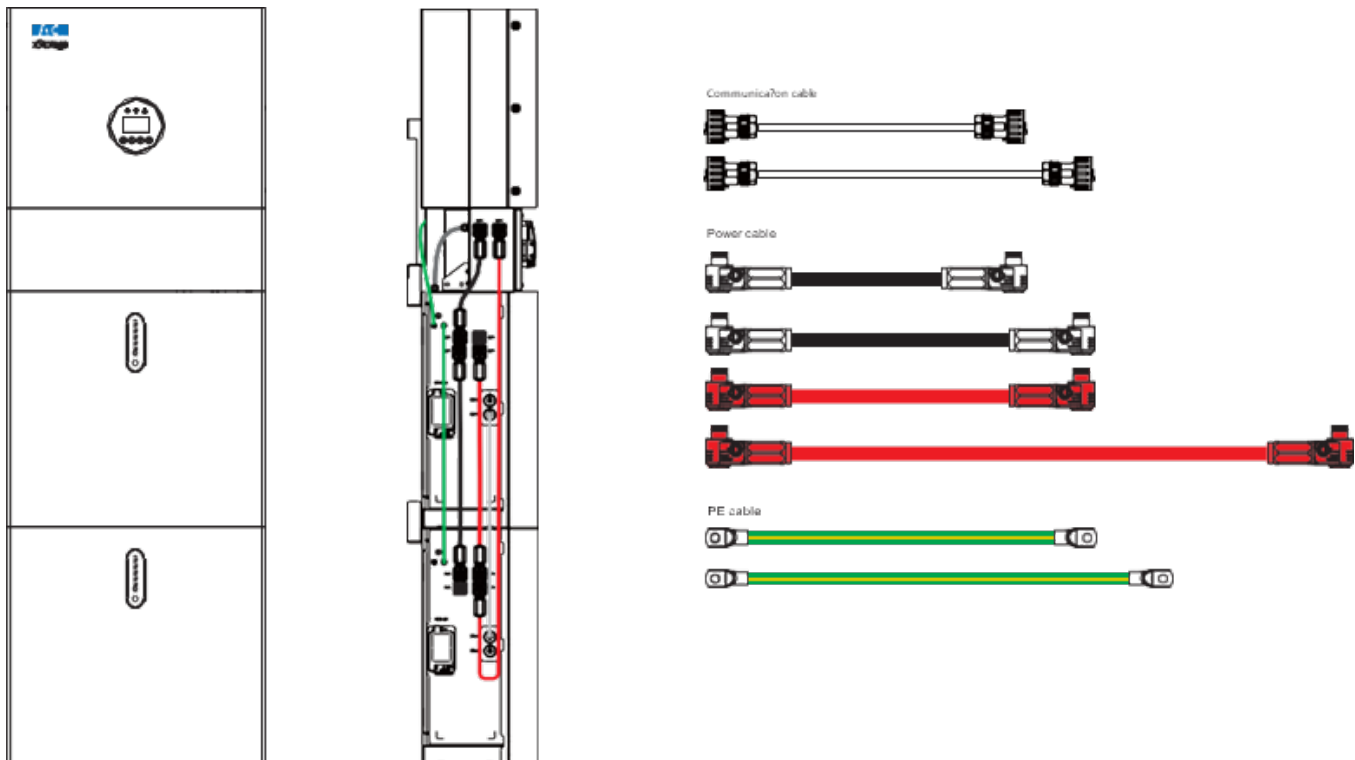

Accessory - Cable (PACK15.3)

Figure 8. Accessory cables 3

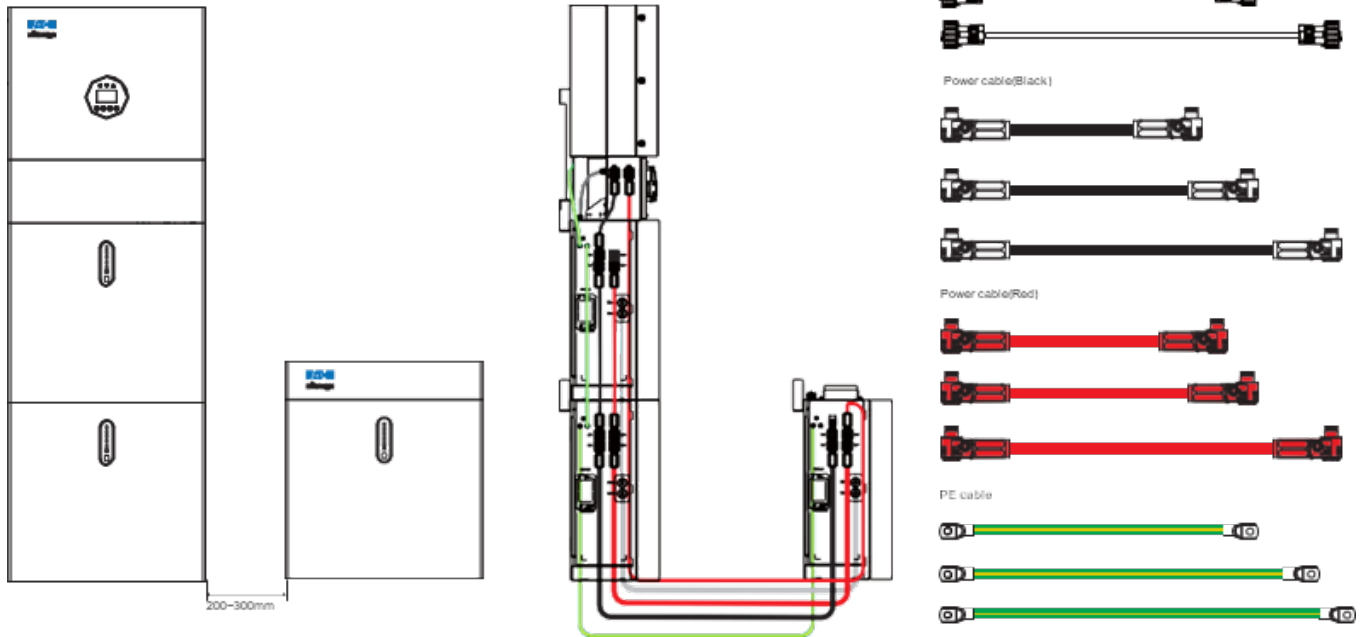

Accessory - Cable (PACK20.4)

Figure 9. Accessory cables 4

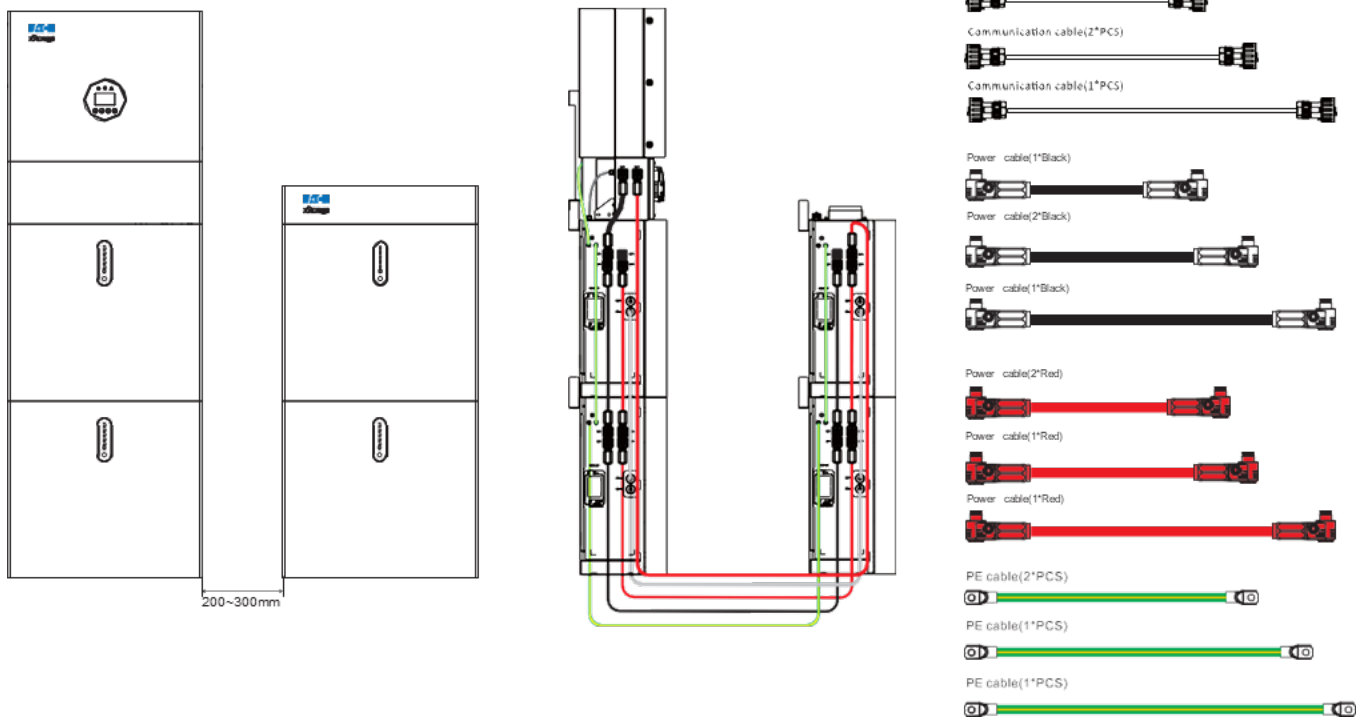

Accessory - Cable (PACK25.6)

Figure 10. Accessory cables 5

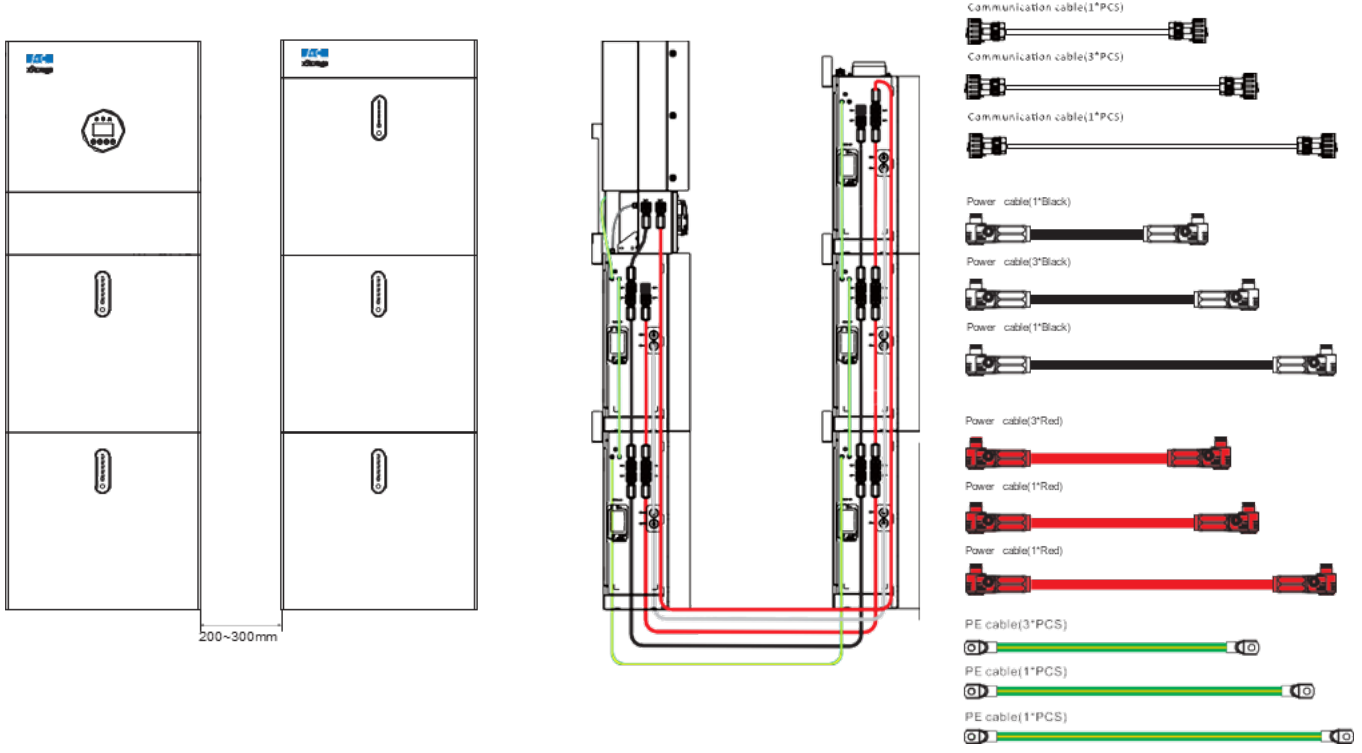
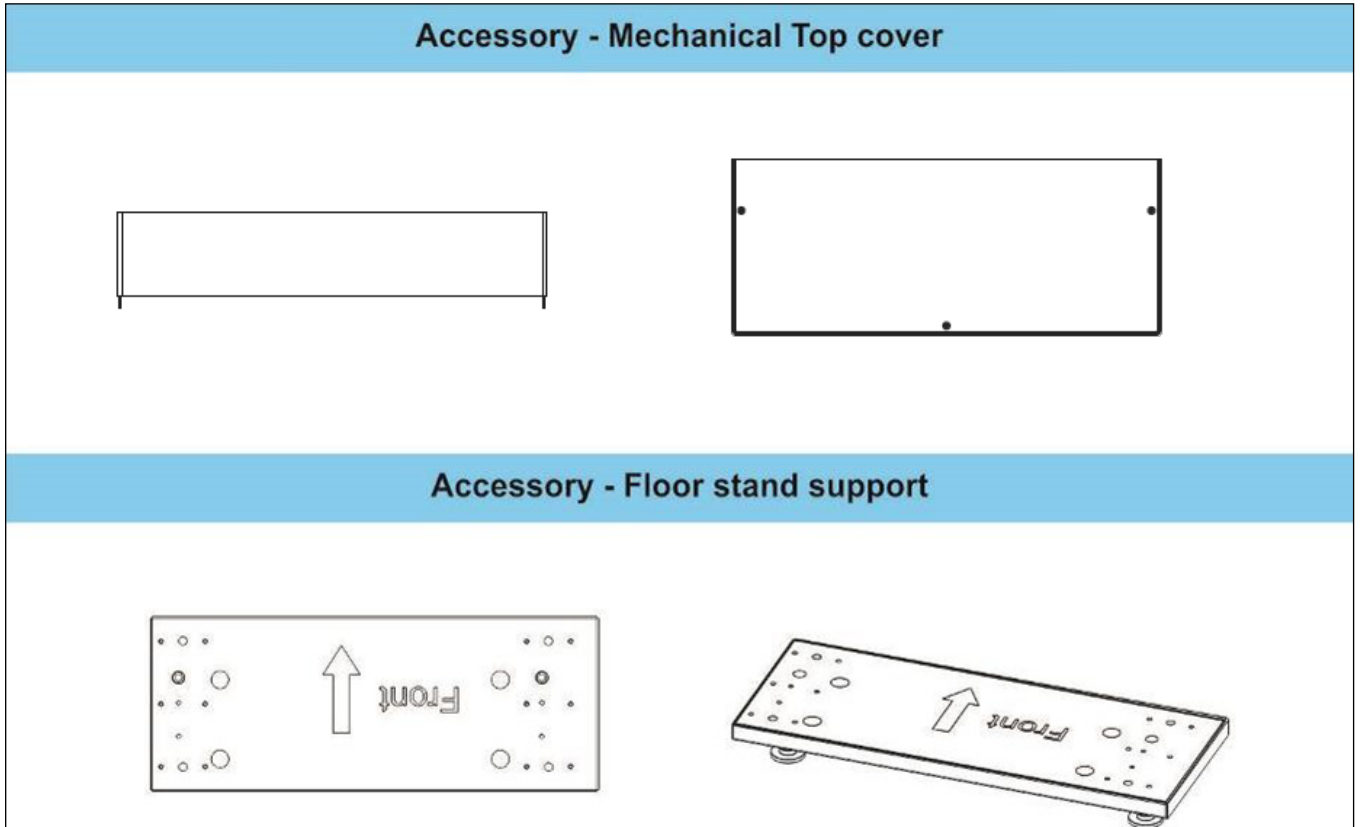
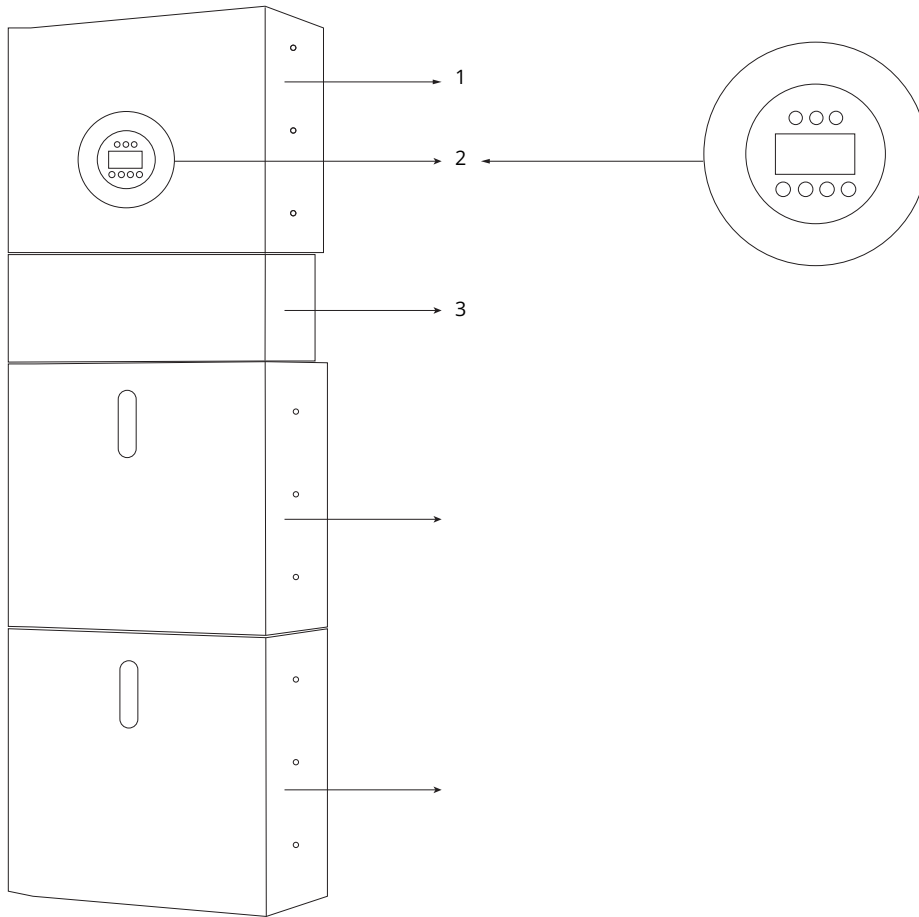

Figure 11. Accessories



1.6 System Appearance

Figure 12. XSTHS1P-3.68K, XSTHS1P-5K, XSTHS1P-6K Delivery Scope



Object	Description
1	Hybrid Inverter
2	EMS Display Screen
3	Cable Box (connected to Inverter)
4	PACK5.1 (Battery 1)
5	PACK5.1 (Battery 2)

1.6.1 Cable Box Part

Figure 13. Inverter without Cable Box Covers - Front View

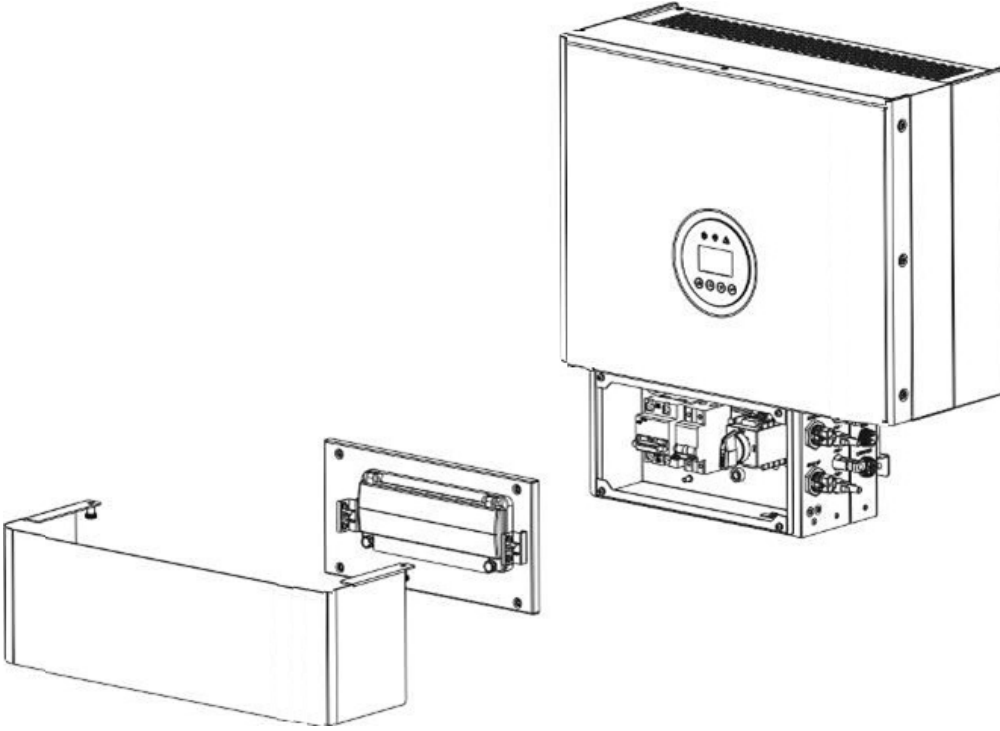
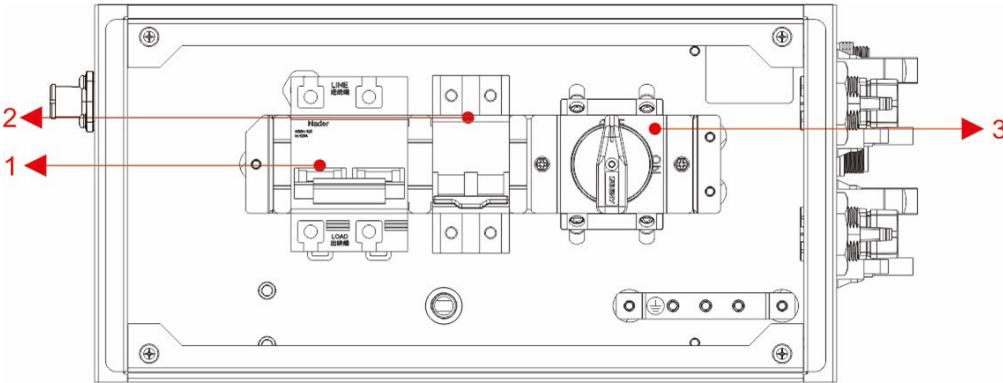
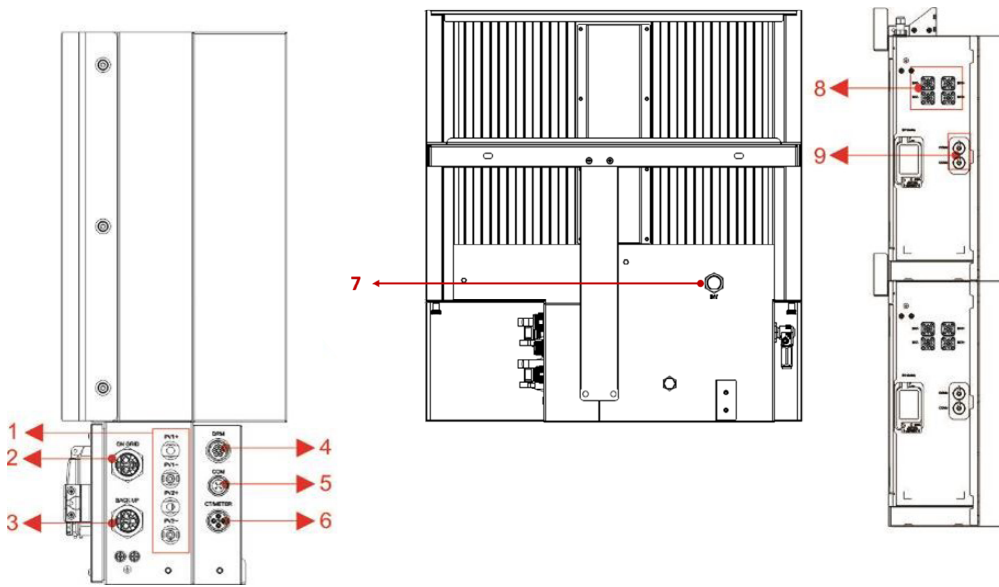

Figure 14. Cable Box Part without Covers - Front View



Object	Description
1	Battery circuit breaker
2	Output Backup circuit breaker
3	DC isolation switch

Figure 15. Cable Box Part without Covers



Object	Description	DVC class	Object	Description	DVC class
1	PV1, PV2	DVC C	2	GRID	DVC C
3	BACKUP	DVC C	4	DRM	DVC A
5	COM	DVC A	6	CT/METER	DVC A
7	INV	DVC C	8	BAT+,BAT-	DVC C
9	RJ45	DVC C			

1.7 Liability Limitation

Any product damage or property loss caused by the following conditions, does not assume any direct or indirect liability.

- Product modified, design changed, or parts replaced without authorization;
- Changes, repair attempts and erasing of series number or seals by non-company technician;
- System design and installation are not in compliance with standards and regulations;
- Fail to comply with the local safety regulations (VDE for DE, SAA for AU);
- Transport damage (including painting scratch caused by rubbing inside packaging during shipping). A claim should be made directly to shipping or insurance company in this case as soon as the container/packaging is unloaded, and such damage is identified;
- Fail to follow any/all of the user manual, the installation guide and the maintenance regulations;
- Improper use or misuse of the device; Insufficient ventilation of the device;
- The maintenance procedures relating to the product have not been followed to an acceptable standard;
- Force majeure (violent or stormy weather, lightning, overvoltage, fire etc.); Damages caused by any external factors.

2. System Operation

2.1 Switch On

When turning on the system, it is very important to follow the steps below to prevent damage to the system.



Please check the installation again before turning on the system.

Figure 16. Turning on the system

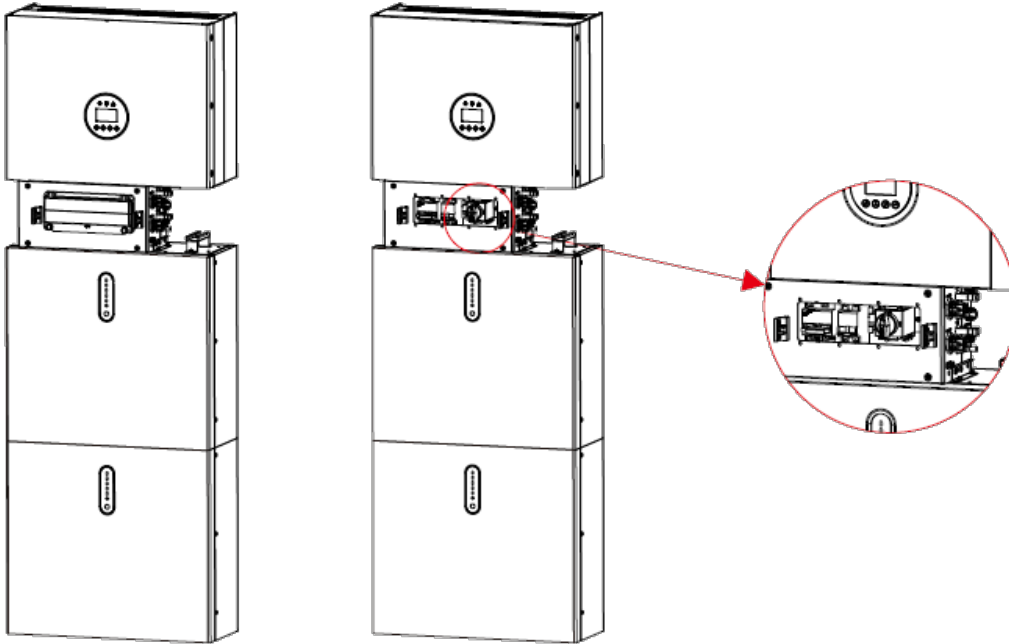

- Step 1.** Open the outer shell of the cable box.
- Step 2.** Turn on the external grid switch.
- Step 3.** Turn on the PV switch.
- Step 4.** Press power button on all the batteries until the indicator lights turn on.
- Step 5.** Open the battery switch cover and turn on the battery switch.
- Step 6.** Turn on the battery switch on the cable box.
- Step 7.** If backup load is applied, turn on the Backup switch.
- Step 8.** Close the battery switch cover and the outer shell of the cable box.



The Backup switch is only used when a backup load is applied.

2.2 Switch Off

- Step 1.** If backup load is applied, turn off the backup switch.
- Step 2.** Turn off the external grid switch.
- Step 3.** Open cable box outer shell and turn off the battery switch.
- Step 4.** Open the battery switch cover and turn off the battery switch.
- Step 5.** Press the power button on all the batteries, till the lights turn off.
- Step 6.** Turn off the PV switch on the cable box.
- Step 7.** Close the battery switch cover and the outer shell of cable box.

2.3 Emergency Procedure

When the xStorage Hybrid energy storage system appears to be running abnormally, you can turn off the grid-connected main switch that directly feeding the BESS, and turn off all load switches within the BESS, turn off the battery switch at the same time. To prevent a potentially fatal personal injury, if you want to repair or open the machine after the power is switched off, please measure the voltage at the input terminals with a suitably calibrated voltage tester. Before working on this equipment, please confirm that there is no grid electric supply to the BESS! The upper cover plate cannot be opened until the DC-link capacitance inside the battery modules discharges completely about 15 minutes later.

2.3.1 Emergency Handling Plan

1. Disconnect the AC breaker.
2. Check the control power supply. If it is OK, return the power supply to find out the reason.
3. Please record every detail related to the fault, so Company can analyses and solve the fault. Any operation of equipment during a fault is strictly forbidden, please contact Company as soon as possible.
4. As battery cells contain a little Oxygen inside and all cells have got explosion-proof valves, explosion hardly happens.
5. When the indicator light on the battery shows a red fault, check the fault type through the communication protocol, and contact our after-sales service personnel for advice.

2.3.2 Hazards

If the battery pack leaks electrolyte, avoid contact with the leaking liquid or gas. If one is exposed to the leaked substance, immediately perform the actions described below:

Inhalation: Evacuate the contaminated area and seek medical attention.

Eye contact: Rinse eyes with running water for 5 minutes and seek medical attention.

Contact with skin: Wash the affected area thoroughly with soap and water and seek medical attention.

Ingestion: Induce vomiting and seek medical attention.

2.3.3 Fire

If a fire breaks out in the place where the battery pack is installed, perform the following countermeasures:

Fire extinguishing media

During normal operation, no respirator is required. Burning batteries can't be extinguished with a regular fire extinguisher, this requires special fire extinguishers such as the Noves 1230, the FM-200 or a dioxin extinguisher. If the fire is not from a battery, normal ABC fire extinguishers can be used for extinguishing.

Fire -fighting instructions.

1. If fire occurs when charging batteries, if it is safe to do so, disconnect the battery pack circuit breaker to shut off the power to charge.
2. If the battery pack is not on fire yet, extinguish the fire before the battery pack catches fire.
3. If the battery pack is on fire, do not try to extinguish but evacuate people immediately.



There may be a possible explosion when batteries are heated above 150°C. When the battery pack is burning, it leaks poisonous gases. Do not approach.

Effective ways to deal with accidents.

Battery in dry environment: Place damaged battery into a segregated place and call local fire department or service engineer.

Battery in wet environment: Stay out of the water and don't touch anything if any part of the battery, inverter, or wiring is submerged.

Do not use a submerged battery again and contact the service engineer.

3. EMS Introduction and Set Up

3.1 Function Description

Figure 17. Hybrid Inverter EMS Interface and PACK interface

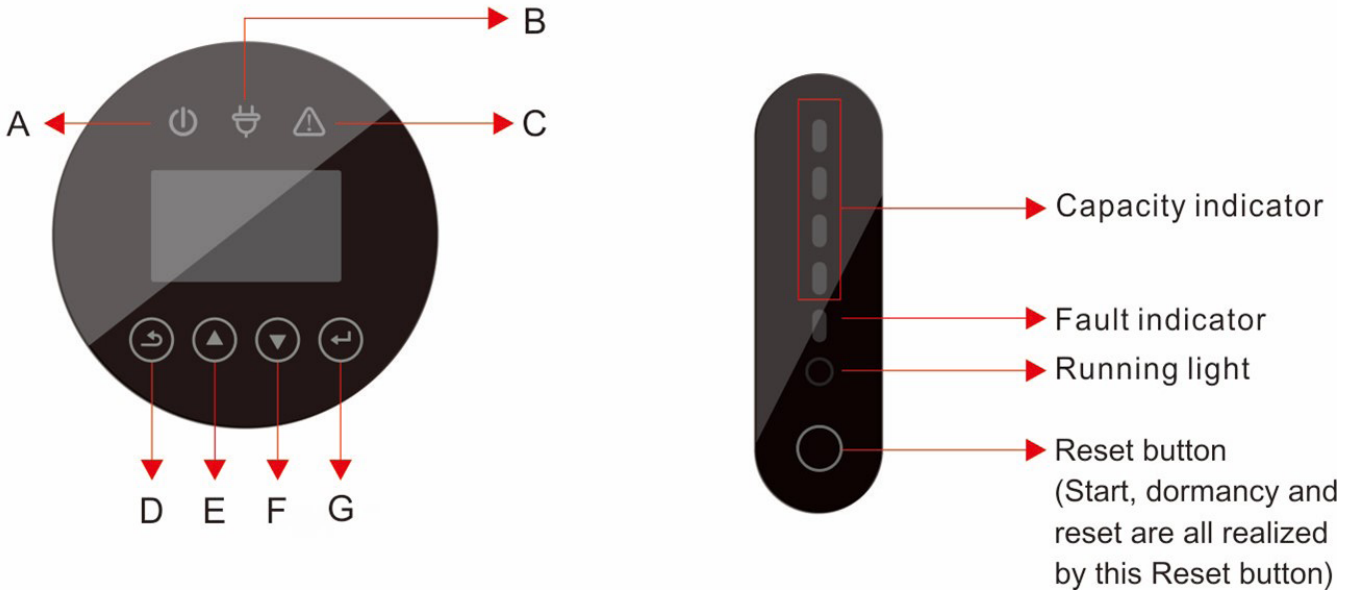

Object	Description	Description
A	Indicator LED	Grid connection
B		Off-grid
C		Red: The inverter is in fault.
D	Button Function	Return Button: Escape from current interface or function. Enter the setting interface.
E		Up button: Move cursor to upside or increase value.
F		Down Button: Move cursor to downside or decrease value.
G		ENT Button: Confirm the selection.

Table 2. LED blink description



Blink Sequence Number	Blink Mode	Blinking (Sec)	Off (Sec)
1	Blinks once every 4 seconds	0.25	3.75
2	Blinks twice every 2 seconds	2 times of 0.25/0.25	1s
3	Blinks three times every 3 seconds	3 times of 0.25/0.25	1.5S

Table 3. Battery level indication - when there is no fault or Alarms

Status	Charging				Discharge				
Battery level indicator	●	●	●	●	●	●	●	●	
Battery level (%)	0-25%	Blinks twice	Off	Off	Off	Off	Constantly On	Off	Off
	26-50%	On	Blinks twice	Off	Off	On	On	Off	Off
	51-75%	On	On	Blinks twice	Off	On	On	On	Off
	76-100%	On	On	On	Blinks twice	On	On	On	On

4. Stick Logger usage

Table 4. Indicator lights

Lights	Implication	Status Description (All lights are single green lights.) Interval
	Communicate with router	Light off: Fail to connect to the router. On 1s/Off 1s (Slow flash): Successful connection to the router. Light keeps on: Successful connection to the server. On 100ms/Off 100ms (Fast flash): Distributing network fast.
	Communicate with inverter	Light keeps on: Logger connected to the inverter. Light off: Fail to connect to the inverter. On 1s/Off 1s (Slow flash): Communicating with inverter.
	Logger running status	Light off: Running abnormally. On 1s/Off 1s (Slow flash): Running normally. On 100ms/Off 100ms (Fast flash): Restore factory settings.

The normal operation status of the stick logger, when router connected to the network normally:

1. Successful connection status with serve: NET light keeps on after the logger powered on.
2. Logger running normally: READY light Flashes.
3. Successful connection status with inverter: COM light keeps on.

4.1 Usage Methods and Notices for Reset Button

Table 5. Usage methods and notices for the reset button

	Keypress	Status Description	Light Status
	Short press 1s	SMARTLINK rapid networking status.	NET light flashes fast for 100ms.
	Long press 5s	Rebooting the stick logger.	All lights are extinguished immediately.
	Long press 10s	Resetting the stick logger.	1. All lights are extinguished after 4s. 2. READY light flashes fast for 100ms.



Do not remove waterproof plug.



8. Fault Diagnosis and Solutions

The inverter is easy to maintain. When you encounter the following problems, please refer to the Solutions below, and contact the local distributor if the problem remains unsolved. The following table lists some of the basic problems that may occur during the actual operation as well as their corresponding basic solutions.

Table 6. Fault diagnosis

Types	Codes	Solutions
Soft Time Out	F00	(1) Restart the inverter and wait until it functions normally; (2) Contact customer service if error warning continues.
INV Volt Short	F01	(1) Cut off all the power and shut down all the machines; disconnect the load and plug in to restart machines, then check whether the load is short circuited if the fault has been eliminated; (2) Contact customer service if fault remains unremoved.
GFCI Sensor Fault	F02	(1) Cut off all the power, Restart the inverter and wait until it functions normally. (2) Contact customer service if error warning continues.
Bus Volt Low	F04 F05	(1) Check the input mode setting is correct. (2) Restart the inverter and wait until it functions normally. (3) Contact customer service if error warning continues.
Bus Volt Short	F06	(1) Restart the inverter and wait until it functions normally. (2) Contact customer service if error warning continues.
PV ISO Under Fault	F07	(1) Check for good ground connection; (2) Check if the earth resistance of PV+ and PV- is greater than 2MΩ; (3) If it is smaller than 2MΩ, check PV string for ground fault or poor ground insulation; if it is greater than 2MΩ, please contact the local inverter customer service once fault is not removed.
PV Input Short Circuit	F08	(1) Check the input mode setting is correct. (2) Disconnect the PV input, restart the inverter and wait until it functions normally. (3) Contact customer service if error warning continues.
Relay Fault	F09 F14 F19	(1) Disconnect the PV input, restart the inverter and wait until it functions normally. (2) Contact customer service if error warning continues.
INV Current Over	F10	(1) Wait five minutes for the inverter to automatically restart; (2) Check whether the load is in compliance with the specification; (3) Contact customer service if error warning continues.
INV DC Over	F11	(1) Restart the inverter and wait until it functions normally. (2) Contact customer service if error warning continues.
NTC/Sink Temp Over	F12 F13	(1) Restart the inverter, restart the machine after a few minutes of cooling, and observe whether the machine can return to normal. (2) Check if the ambient temperature is outside the normal operating temperature range of the machine. (3) Contact customer service if error warning continues.
Dischg Curr Over	F15	(1) Wait one minute for the inverter to restart; (2) Check whether the load is in compliance with the specification; (3) Contact customer service if error warning continues.
CHG Current Over	F16	(1) Check if battery wiring port is short circuited; (2) Check if charging current is in compliance with presetting; (3) Contact customer service if error warning continues.
Current Sensor Fault	F17	(1) Restart the inverter and wait until it functions normally. (2) Contact customer service if error warning continues.
INV Abnormal	F18	(1) Please contact the distributor.
EPS Relay Fault	F19	(1) The off-grid relay is faulty. (2) Contact customer service if error warning continues.
always Overload	F20	(1) The system load always exceeds the rated value. (2) Contact customer service if error warning continues.
Communication Fault	F32	(1) Restart the inverter and wait until it functions normally. (2) Contact customer service if error warning continues.

Types	Codes	Solutions
Grid Fault	W00 W01 W02 W03	(1) Check if the local voltage and frequency is in compliance with the machine specification; (2) If voltage and frequency are within the accepted range, then wait 2 minutes for the inverter to function normally; but if no recovery or fault repeats, please contact the local inverter customer service; (3) Contact the local power company if voltage and frequency are beyond range or unstable.
Solar Loss	W04	(1) PV is not connected; (2) Check grid connection; (3) Check PV availability.
Bat Loss	W05	(1) Battery is not connected; (2) Check if battery wiring port is short circuited; (3) Contact customer service if error warning continues.
Bat Volt Low	W06 W07	(1) Check the battery availability; (2) Contact customer service if error warning continues.
Bat Volt High	W08	(1) Check if the battery is in line with the presetting; (2) If so, power off and restart; (3) Contact customer service if error warning continues.
Overload Warning	W09	(1) Wait one minute for the inverter to restart; (2) Check whether the load is in compliance with the specification;
GFCI Over	W10	(1) Check PV string for direct or indirect grounding phenomenon; (2) Check peripherals of machine for current leakage; (3) Contact the local inverter customer service if fault remains unremoved.
LN Reverse	W11	(1) Check whether the installation follows the instructions; (2) Contact customer service if error warning continues.
Fan Fault	W12	(1) Restart the inverter and wait until it functions normally. (2) Contact customer service if error warning continues.
BMS Fault	W14~W27	(1) Please contact the distributor.
CT Reverse	W28	(1) Perform CT self-check; (2) Contact customer service if error warning continues.
Clock Initiate Fail	W29	(1) Restart the inverter and wait until it functions normally. (2) Contact customer service if error warning continues.

10. Routine Maintenance

10.1 Maintenance Plan

- Check if wire connections are loose.
- Check if cables are aged/damaged.
- Check if cable insulating ribbon drops.
- Check if cable terminal is loose, any overheat sign.
- Check if ground connection is good.

10.1.1 Operating Environment

(Every six months)

Carefully observe whether the battery system equipment is ineffective or damaged;

When the system is running, listen to any part of the system for abnormal noise;

Check whether the voltage, temperature and other parameters of the battery and other equipment parameters are normal during system operation;

10.1.2 Equipment Cleaning

(Every six months to one year, depending on the site environment and dust content, etc.) Ensure that the ground is clean and tidy, keep the maintenance access route unblocked, and ensure that the warning and guiding signs are clear and intact.

Monitor the temperature of the battery module and clean the battery module if necessary.

10.1.3 Cable, Terminal, and Equipment Inspection

(Every six months to one year)

- Check if the cable connections are loose. Check whether the cables are aged / damaged.
- Check whether the cable tie of the cable has fallen off.
- Check if the cable terminal screws are loose and the terminal position has any signs of overheating.
- Check whether the management system of the system equipment, monitoring system and other related equipment are invalid or damaged.
- Check that the grounding of the equipment is good, and the grounding resistance is less than 10 ohms.

10.2 Notes

After the equipment is out of operation, please pay attention to following notes while maintaining:

- Related safety standards and specifications should be followed in operation and maintenance.
- Disconnect all the electrical connections so that the equipment would not be powered on.
- Wait at least 5 minutes after disconnection, so that the residual voltage of the capacitors drops to a safe voltage. Use a multimeter to make sure that the equipment is completely discharged.
- The equipment should be repaired by professional staff only and it is strictly forbidden for maintenance staff to open equipment modules on their own.
- Appropriate protective measures should be taken while maintaining, such as insulated gloves, shoes, and anti-noise ear plugs.
- Life is priceless. Make sure no one would get hurt first.
- In case of a deep discharge, the battery must be charged to a SOC rate of 30% to 50%. If the entire system is static (i.e., the battery has not been charged for two weeks or more).

Please contact us in time if there are any conditions that could not be explained in the manual.

11. Quality Assurance

When product faults occur during the warranty period, his partner will provide free service or replace the product with a new one.

Evidence

During the warranty period, the customer shall provide the product purchase invoice and date. In addition, the trademark on the product shall be undamaged and legible. Otherwise, company has the right to refuse to honor the quality guarantee.

Conditions

Please refer to the xStorage Hybrid warranty conditions documentation on the website www.eaton.com/xstoragehybrid.

Cybersecurity recommendations

To protect and protect yourself from any cyberattack, Eaton strongly recommends that you change your password after completing commissioning. Write down and store your password in a safe place hidden from everyone so you can find it if you need to change your settings.

Monitoring through applications

Note:

At Eaton we do not currently have a Mobile or Web application capable of connecting to products. Customer can connect their own application such as a Home assistant to monitor their production, consumption and be notified of possible events appearing on its installation. Some apps such as Solarman app, BliQ app for (NL and BE) can be used.

For more information, please visit:
eaton.com/xstoragehybrid



Eaton Manufacturing LP, Morges Branch
Chemin de Maillefer 61,
1052 Le Mont-sur-Lausanne,
Switzerland
[Eaton.com/xstoragehybrid](https://eaton.com/xstoragehybrid)

©2024 Eaton
All Rights Reserved
Publication No. IL700002EN
June 2024

Changes to the products, to the information contained in this document, and to prices are reserved; so are errors and omissions. Only order confirmations and technical documentation by Eaton is binding. Photos and pictures also do not warrant a specific layout or functionality. Their use in whatever form is subject to prior approval by Eaton. The same applies to Trademarks (especially Eaton, Moeller, and Cutler-Hammer). The Terms and Conditions of Eaton apply, as referenced on Eaton Internet pages and Eaton order confirmations.

Eaton is a registered trademark.

All other trademarks are property of their respective owners.

Follow us on social media to get the latest product and support information.

