

xStorage Hybrid Inverter Single-phase LFP Battery Solutions

Quick Start Guide

Never turn on equipment when there is evidence of fire or structural damage.

xStorage Hybrid must be installed only by professional and qualified personnel.

During installation, unplug xStorage Hybrid. Read and understand the safety instructions and warnings prior to installation.

1. Battery Installation

Step 1 Remove the battery and inverter from the packaging box.

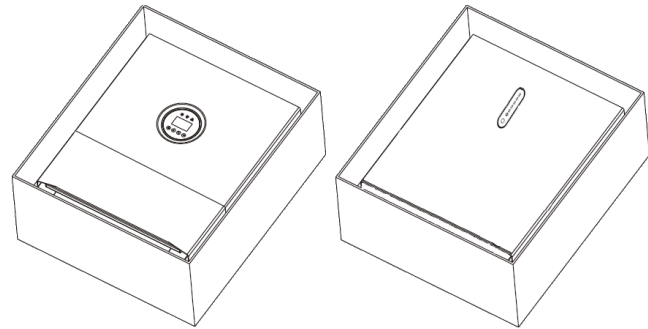

Step 2 Assemble the battery mounting panel on the battery.

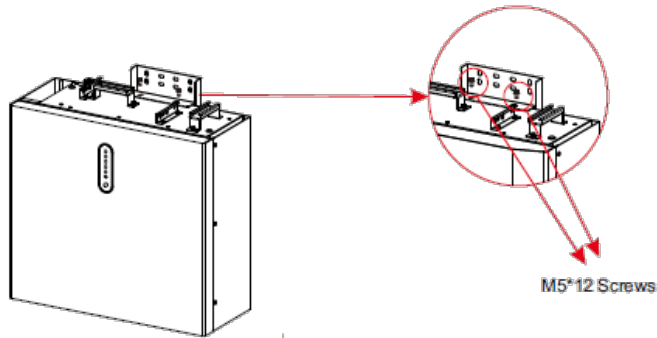

Step 3 Position the battery parallel to the wall and use a $\Phi 8$ mm drill to drill holes at a depth of about 70mm in the wall for subsequent fixation of the mounting plates.

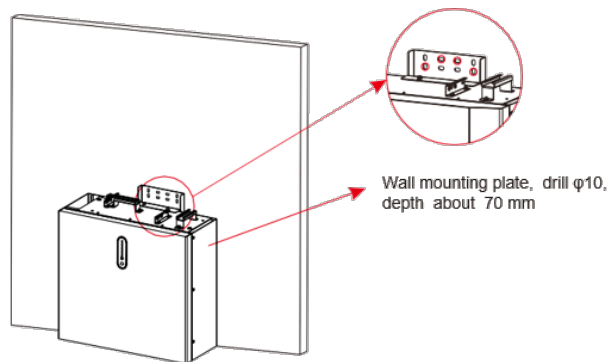

The type B RCD must be installed on the backup port of the system. In addition, the installation of inverter must fulfill AS/NZS 3000, AS/NZS 4777.1 and AS/NZS 5033.

Step 4 Please use the appropriate wall plugs and screws for the wall on which you plan to attach the battery mounting bracket

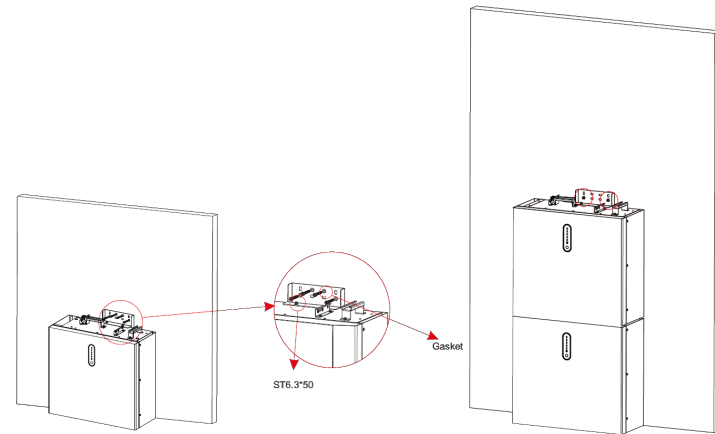

Step 5 To assemble the second (and all other) battery, repeat steps 2 and 3 respectively.

2. Inverter Installation

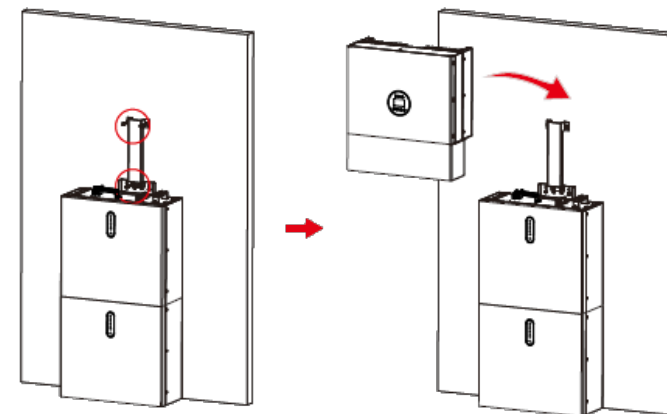

Step 1 Hang the inverter onto the mounting panels, adjust the entire system and ensure that the battery and the inverter have been securely hung onto the panels and brackets.

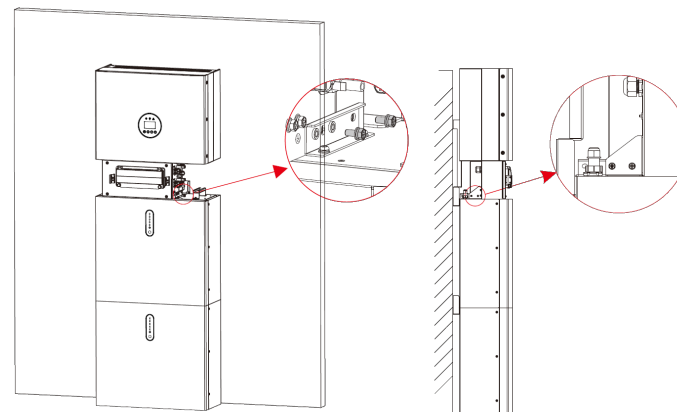

Prior to installation it is required to download (www.eaton.com/xstoragehybrid), read, and understand the step-by-step instructions from the latest installation and user manuals.

3. AC cable assembly and connection

Recommended cables: a 12 AWG or 4 -mm² cable for BACK UP connection and a 10 AWG or 6 -mm² cable for ON GRID connection. Make sure that the resistance of the wires is lower than 1 Ω . If the wire is longer than 20m, we recommend using a 10mm² cable.



There are "L" "N" "PE" symbols marked inside the connector, the Line wire of grid must be connected to "L" terminal; the Neutral wire of grid must be connected to "N" terminal; the Earth of grid must be connected to "PE"

Object	Description	Value
A	External diameter	12mm to 18mm
B	Copper conductor cross-section	4mm ² to 10mm ²
C	Stripping length of the insulated conductors	approx. 13mm
D	Stripping length of the outer sheath of the AC cable	approx. 53mm

The PE conductor must be 10mm longer than the L and N conductors



Step 1 Insert the conductor into the suitable ferrule acc. to DIN 46228-4 and crimp the contact

Step 2 Unscrew the swivel nut from the threaded sleeve and thread the swivel nut and threaded sleeve over the AC cable.

Step 3 Insert the crimped conductors L, N and PE into the corresponding terminals and tighten the screw with a hex key wrench screwdriver (size: 2.5, 1.2-2.0Nm). Ensure that all conductors are securely in place in the screw terminals on the bush insert.

Step 4 Screw the swivel nut onto the threaded sleeve. This seals the AC connector and provides strain relief for the AC cable. When doing so, hold the bush insert firmly by the locking cap. This ensures that the swivel nut can be screwed firmly onto the threaded sleeve.

Step 5 Assemble the plug shell, adapter as below picture, Push the adapter and Shell by hand until a "Click" is heard or felt.

Step 6 Plug the AC connector into the jack for the AC connection by hand until a "Click" is heard or felt.



4. Battery cable assembly and connection

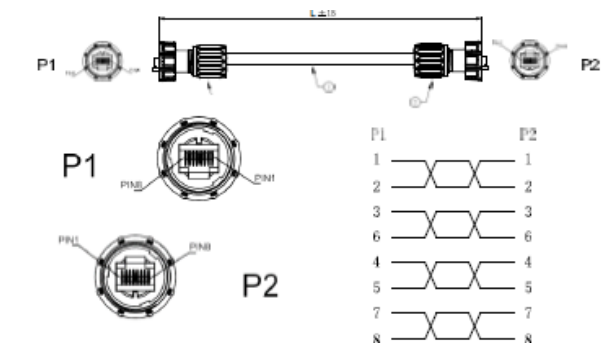

The communication cable is in type B, see Figure . Leave the power cables and communication cables hanging on outside. Leave the device aside.

Step 1 Connect the BAT communication cable of the cable box to the topmost battery at the right side.

Step 2 Use the communication cable supplied with the batteries to connect the batteries to each other via the respective connectors on the left side.

Step 3 After you have connected all the modules together, close all covers (if you want to connect further battery modules, you must mount them before closing).

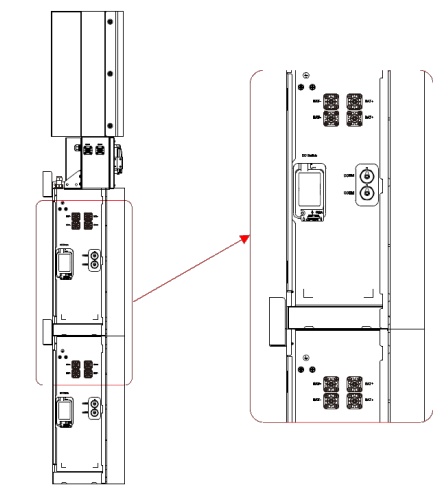

xStorage Hybrid Inverter Single-phase LFP Battery Solutions

Quick Start Guide

Never turn on equipment when there is evidence of fire or structural damage.

xStorage Hybrid must be installed only by professional and qualified personnel.

During installation, unplug xStorage Hybrid. Read and understand the safety instructions and warnings prior to installation.

Step 4 Connect the power cables of the bottom battery to the side terminals of the top battery. Make sure that red connects to red and black connects to black.

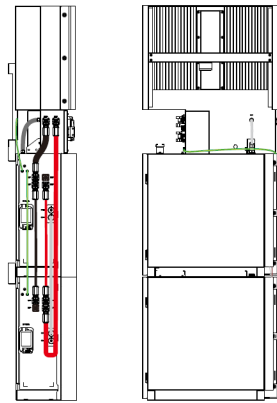

Step 5 Close the battery covers and connect the PV-MC4 connectors to the system (connect ion on both sides).

Step 6 Connect all AC cables, the meter communications cable METER, and the Ethernet cable LAN.

Step 7 Close the cable box cover.

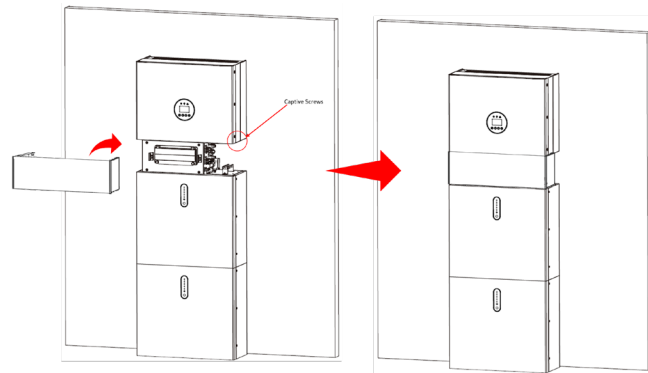

Step 8 Close the lid and tighten the screw. The installation is now complete.

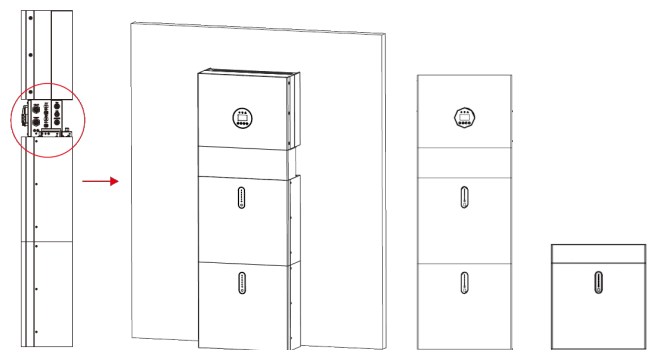

If you connect more than 2 battery modules to the system, please only install the additional batteries. If you connect more than 2 battery modules to the system, please only install the additional batteries 3, 4 & 5 on the side of the system. You can connect to 5 batteries, 3 each mounted on top of each other, to the XST Home Inverter.

To do this, carry out the individual installation steps as for the first two batteries.

5. External CT connection

The electricity meter should be mounted and connected at the grid transition point (feed-in point) so that it can measure the grid reference and feed-in power.

Step 1 Loosen the nut and untangle the single-aperture sealing ring.

Pin	Description	Pin	Description
1	CTpositiveelectrode(White)	3	RS485-A
2	CTnegativepole(Black)	4	RS485-B

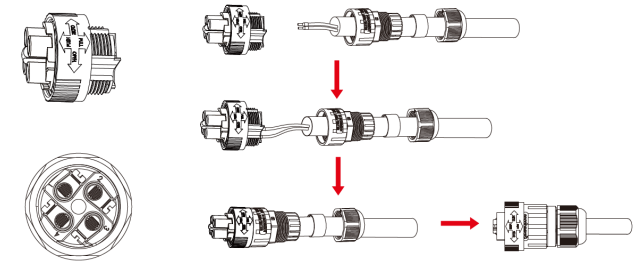

Step 2 Install the waterproof component and screw on the waterproof sheath nut

Step 3 Open the external CT wiring port, the arrow points to the direction of the power grid, put the wire into the external CT card slot, and buckle the buckle.

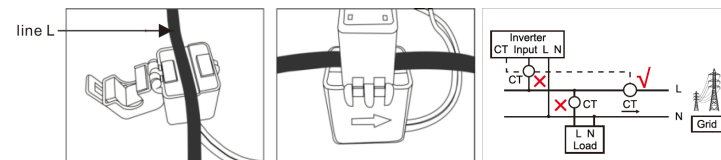

External CT should be placed near the power grid. If CT test passes but inverter still can't achieve export power (power is not controllable or always 0 power output), check installation location of the CT.

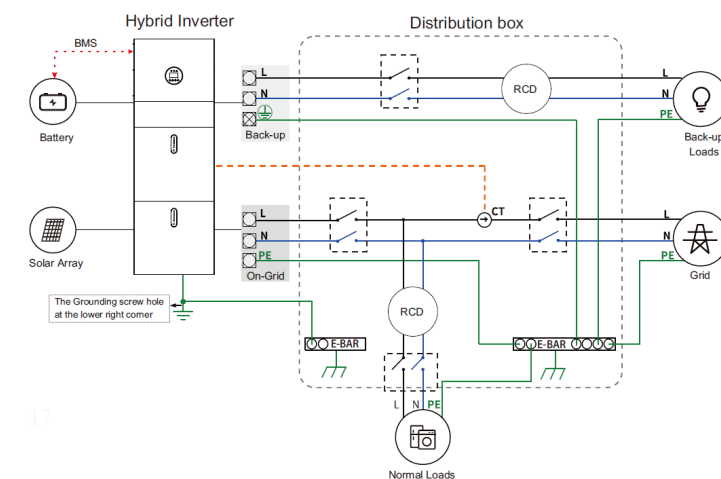

Prior to installation it is required to download (www.eaton.com/xstoragehybrid), read, and understand the step-by-step instructions from the latest installation and user manuals.

6. Switch On

When turning on the system, it's very important to follow steps to prevent damage to the system.



Please check the installation again before turning on the system

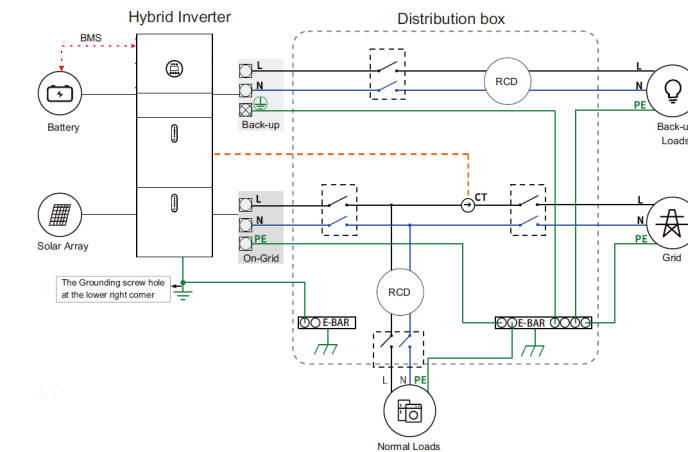

Step 1 Open the outer shell of the cable box.

Step 2 Turn on the external grid switch.

Step 3 Turn on the PV switch.

Step 4 Press power button on all the batteries until the indicator lights turn on.

Step 5 Open the battery switch cover and turn on the battery switch.

Step 6 Turn on the battery switch on the cable box.

Step 7 If backup load is applied, turn on the Backup switch.

Step 8 Close the battery switch cover and the outer shell of the cable box.



The Backup switch is only used when a backup load is applied.

7. Connect Wi-Fi Datalogger

Step 1 Select the same number of Wi-Fi PlugII PN to connect on your phone WLAN. The Password can be found on the label of the collector

Step 2 Open the APP, tap the Wi-Fi Config button to enter this page.

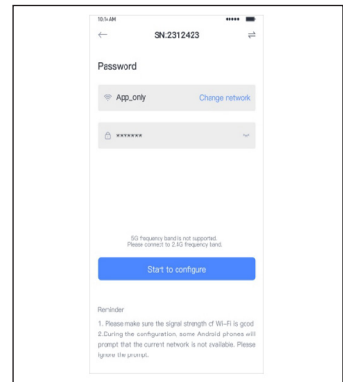
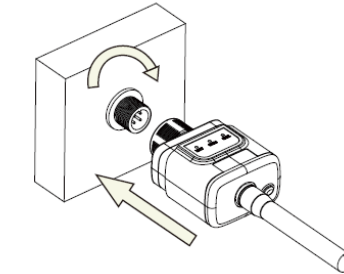

Please do not hold the logger body to rotate while install or remove the logger.

