

# HD TAB 900

## & TAB 900 Plus

9"

TFT 16:10



PLAN	MODULAT	BW	DC@RF	FREQ	CHAN
EUROPE	DVB-T2	8	OFF	810.00	63

POWER : 72.2 dBuV

30	45	60	75	90	105	120
----	----	----	----	----	-----	-----

MER : 35.2 dB      SNR : 35dB

8	12	16	20	24	28	32	36	40
---	----	----	----	----	----	----	----	----

NsMAR : 17.1 dB      QLY : PASS

-1	3	7	11	15	19	23
----	---	---	----	----	----	----

6x10<sup>-4</sup>      <10<sup>-8</sup>

bBER      LBER

VPID : 100      APID : 101

ENCRYPT.:      256QAM Clear

NID: 2000      NETW: Network      MENU & ?

Professional HD SAT, TV, CATV & Optical Analyzer 4-2600 MHz

WIDE BAND

CE

DVB-T2/C/S2

## USER'S GUIDE



[www.roverinstruments.com](http://www.roverinstruments.com)

# GET TO KNOW YOUR TAB 900

## FRONT PANEL



**NB:** The MENU (functions and Graphics) can be changed without notice.

### • POWER



To turn on press the 'HOME' key.



To turn off press and hold the 'HOME' key

### • WHEEL

Use the wheel to navigate across the screen and adjust the values



Rotate to select a menu item or to change a value



Press to select a menu item or a numeric field,



Select a menu item, press and hold 2" to display the pop-up menu.

### • RESET HARDWARE



With instrument ON, keep the "HOME" key pressed for 10" and turn on again.

### • RESET SOFTWARE



+



From instrument OFF, Switch on the meter, immediately after keep the "VOLUME" key pressed until a beep is heard.

# SIDE PANELS

## • LEFT SIDE

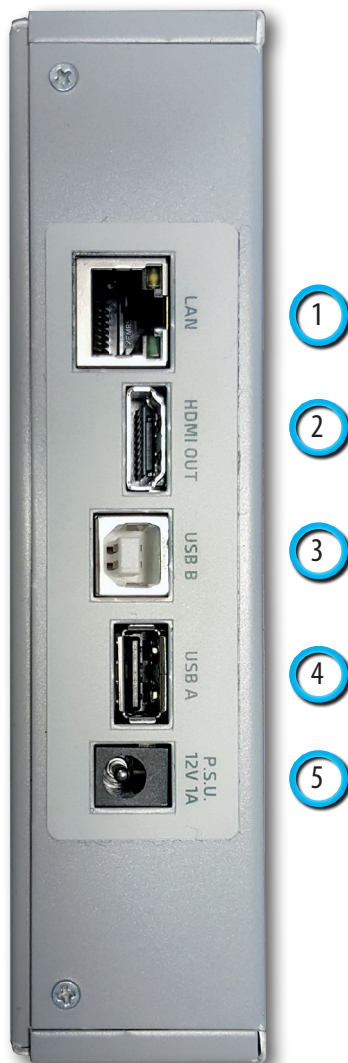

## • RIGHT SIDE



## • TOP SIDE



- |    |   |                                   |     |   |  |
|----|---|-----------------------------------|-----|---|--|
| 1. | = | LAN Ethernet RJ45                 | 7.  | = | Analog video IN (CVBS)                           |
| 2. | = | HDMI Output                       | 8.  | = | Remote Power Supply switch<br>DC at RF IN ON/OFF |
| 3. | = | USB B SW upgrades                 | 9.  | = | IF/RF IN "F" 75 Ω                                |
| 4. | = | USB A memory stick                | 10. | = | OPTIC IN: SC opt.                                |
| 5. | = | Power Supply input (12 V DC - 2A) |     |   |  |
| 6. | = | Fan                               |     |   |  |

# MULTI-PURPOSE BAG

Make work easier by taking advantage of your multi-purpose bag.



1

Work safely and without restrictions with both hands free.

Connect the shoulder strap to the two hooks at the corners of the bag (top left and bottom right), so you can hang your meter around your neck leaving both hands free.

2



3

The sunlight shield flap allows improved visibility of the high brightness display.

4

Secure your meter by connecting it to the antenna mast or in your car using the practical ring belt with quick attachment.



5

If you change the configuration of the shoulder strap, you can easily carry the meter vertically by your side.

6

You can also carry your instrument using its practical handle.



7

You can use the bag's convenient stand flap for operation on a counter.

# HOME AND NAVIGATION

## 'HOME' SCREEN

Press the 'HOME' key to go to the home screen, then rotate the wheel to navigate on 'SAT', 'TV' or 'CATV' icons and press the wheel to select the measurement mode required.



Press the 'HOME' key at any time to return to the home screen

## NAVIGATION

Use the touch screen and the wheel to navigate across the screen and to change values

### DISPLAY ZONES

- 1 tuning parameters
- 2 live picture
- 3 measurements
- 4 channel info
- 5 transport stream info
- 6 context sensitive menu

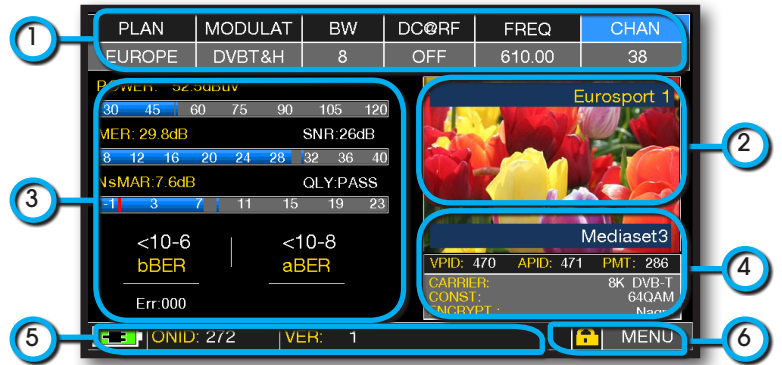

### NAVIGATION USING MECHANICAL COMMANDS

How to select from the menus and adjust the value:

- Rotate the wheel and select from the menu required (fig. 1)
- Press the wheel (fig. 2)
- Rotate the wheel to adjust the value (fig. 3)
- Press the wheel and confirm the selection (fig. 4)

Example of TV/CATV channel selection:



Example of SATELLITE transponder selection (TP/TS):



Example of remote TV-CATV power supply selection (DC&RF):



How to select from the menus and change a value using the drop down menus:

- Rotate the wheel and select the menu required (fig. 1)
- Keep the wheel pressed for 2" to visualized the drop down menu (fig. 2)
- Rotate the wheel to adjust the value (fig. 3)
- Press the wheel and confirm the selection (fig. 4)

Example of TV/CATV channel selection:

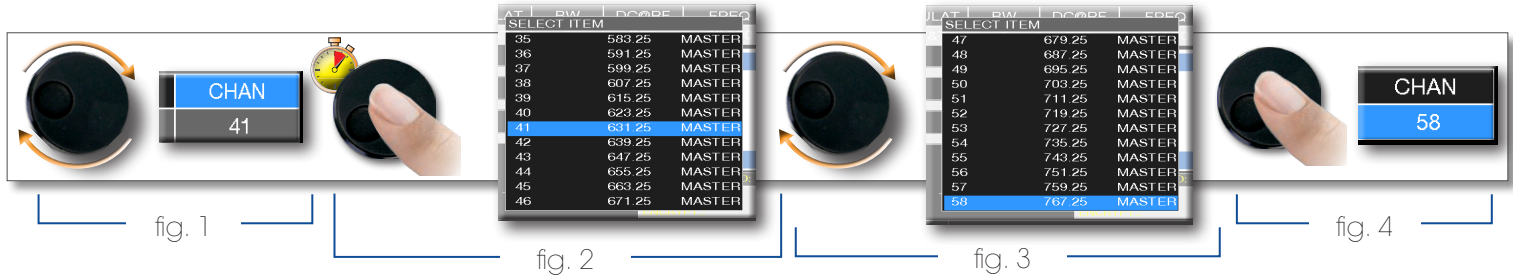

Example of SATELLITE transponder selection (TP/TS):

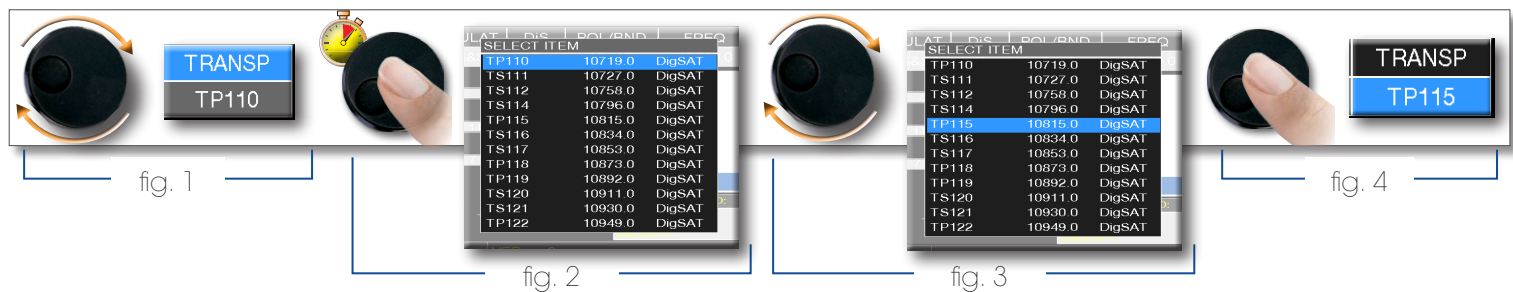

How to select the frequency and set the value using the numerical keyboard:

- Rotate the wheel and select frequency (FREQ) (fig. 1)
- Keep the wheel pressed for 2" to visualize the keyboard (fig. 2)
- Press the relative number keys to digit the frequency value required, rotate the wheel to navigate within the window (fig. 3)
- Finally rotate the wheel and select enter (fig. 4)
- Press the wheel and confirm the selection (fig. 5)

Example of manual frequency (FREQ) selection:

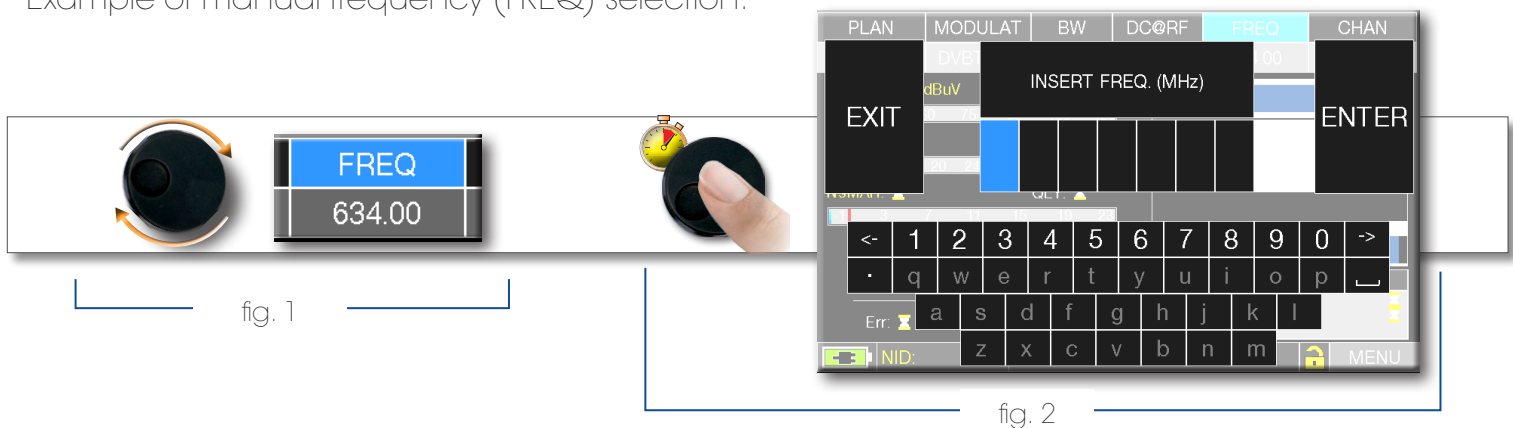

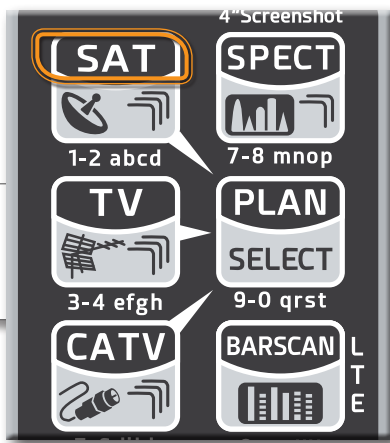

fig. 3



fig. 4



fig. 5

## NAVIGATION USING MIXED COMMANDS: MECHANICAL & TOUCH

- Touch a value in the menu (fig. 1)
- Rotate the wheel to adjust the value (fig. 3) or touch the value required (fig.2)
- Press the wheel and confirm the selection (fig.3) or touch the monitor outside the drop down menu (fig.3)

Select from the menus and adjust the value using the drop down menu:

- Touch a value in the menu to visualize the drop down menu (fig. 1)
- Rotate the wheel to adjust the value (fig. 2) or touch the value required (fig. 2)
- Press the wheel and confirm the selection (fig. 3), or touch the monitor outside the drop down menu (fig. 3)

Example of TV channel selection:

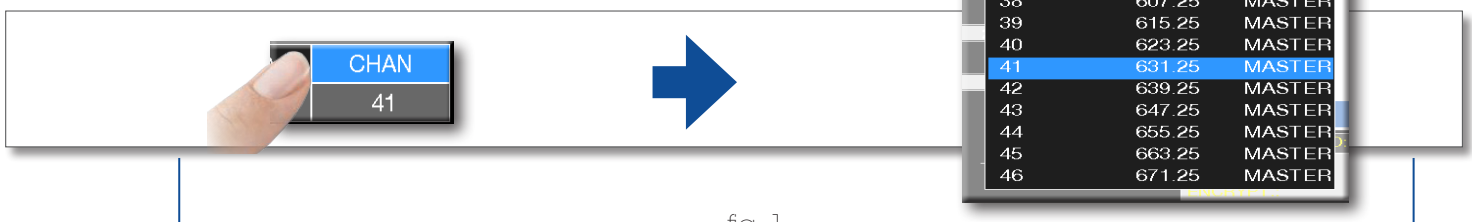

fig. 1

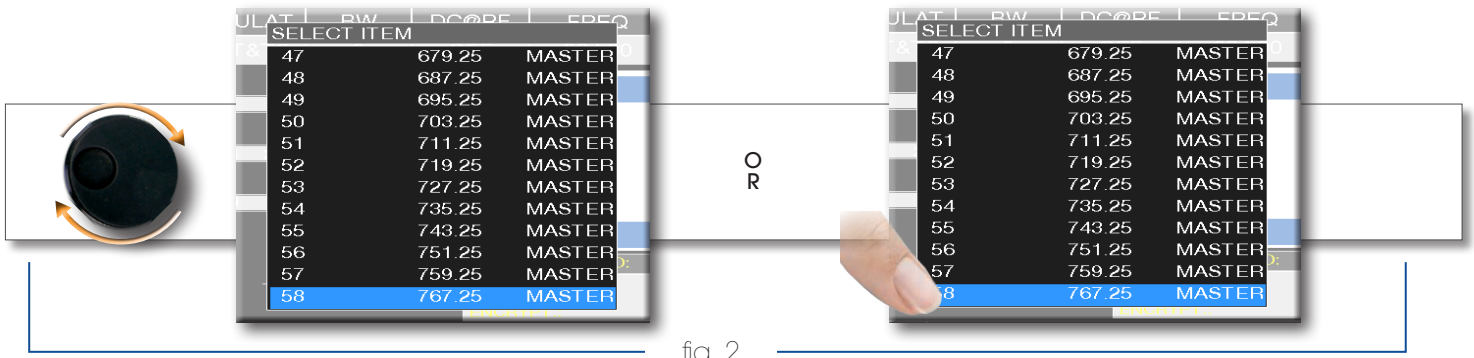

fig. 2



fig. 3

Example of SATELLITE transponder selection (TP/TS):

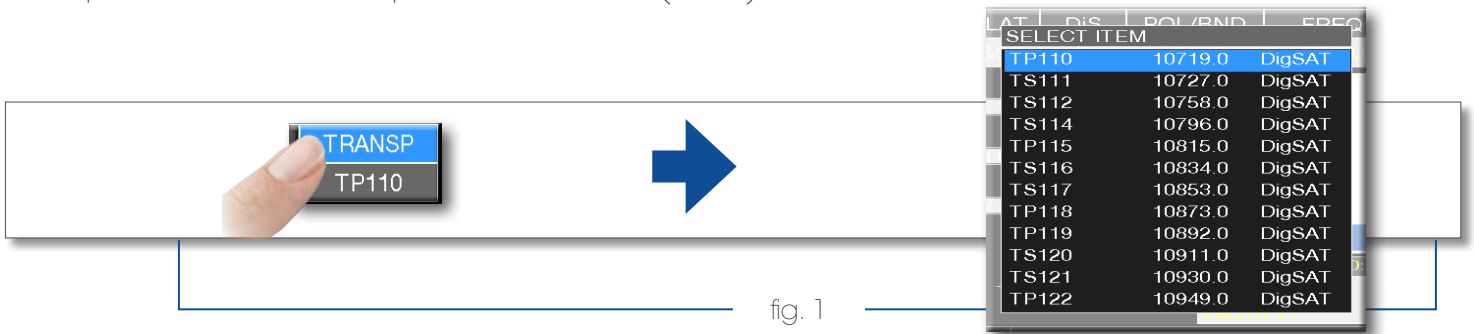

fig. 1

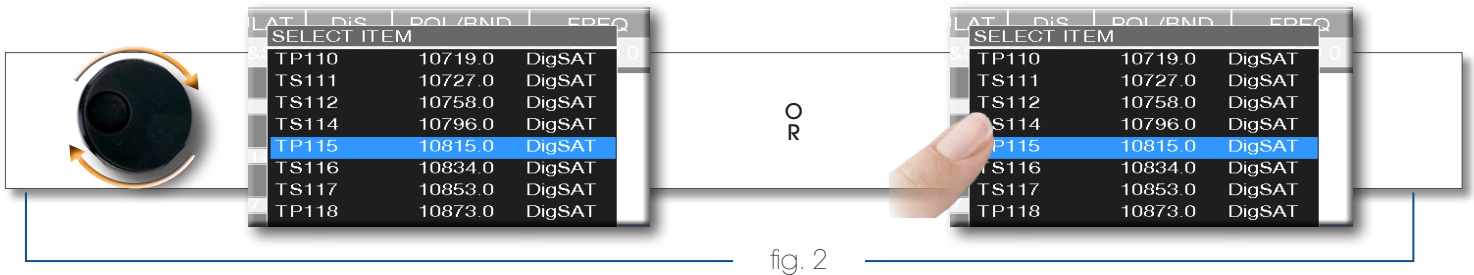

fig. 2

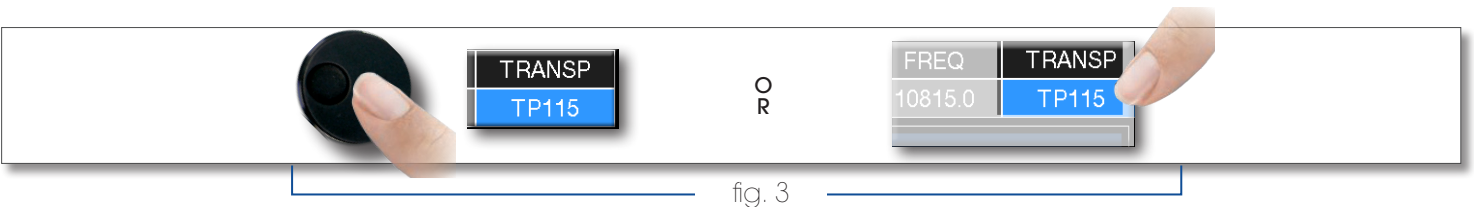

fig. 3



Select the frequency and set the value using the numerical keyboard:

- Touch **FREQ** to show the menu "INSERT FREQ" (fig. 1)
- Touch the numbers to digit the required frequency value (fig. 2)
- Finally touch enter and confirm the selection (fig. 3)

Example of manual frequency selection (FREQ):

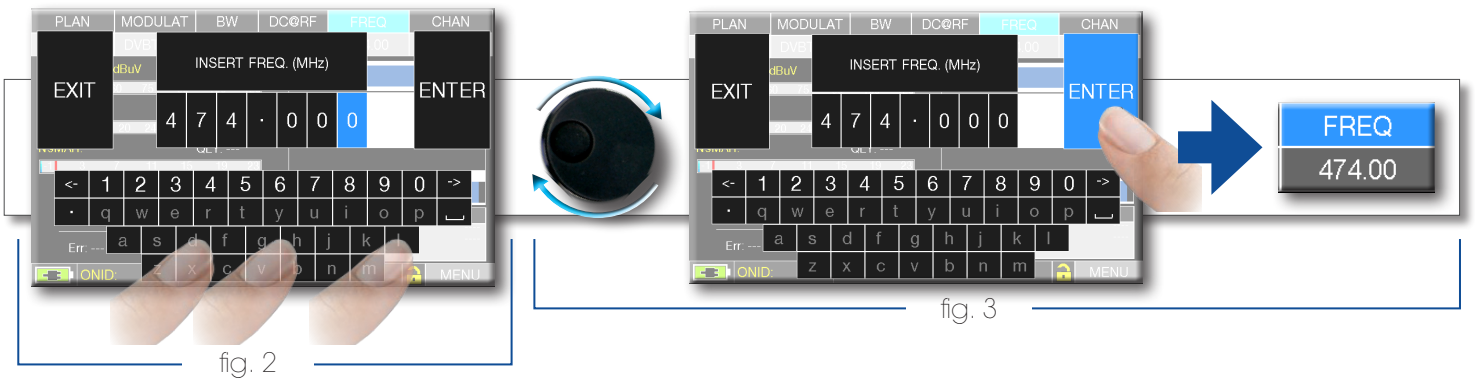
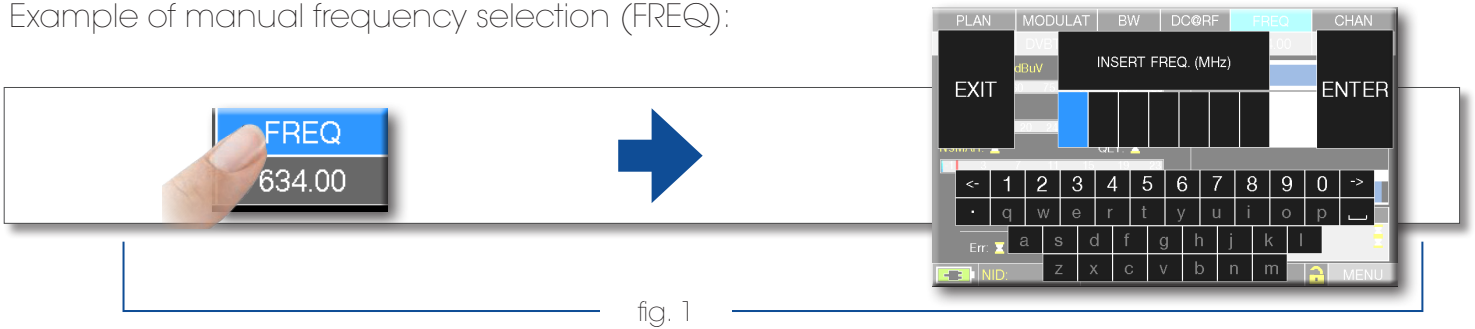

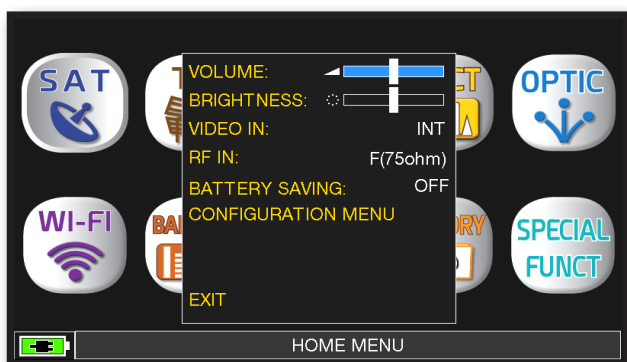

Volume selection is immediately active, press "ENTER" for the Display configuration and other important settings

## VIDEO IN AND HDMI OUT

- "HDMI OUT" (connector 2): Connect an HDMI cable to automatically send the TFT monitor pictures to a TV or video projector. The video will only be available on an external display;
- "VIDEO IN" (connector 7): Select "EXT" to visualize an external video source.

## BATTERY SAVING AND TIMER OFF

Settings for battery save mode.

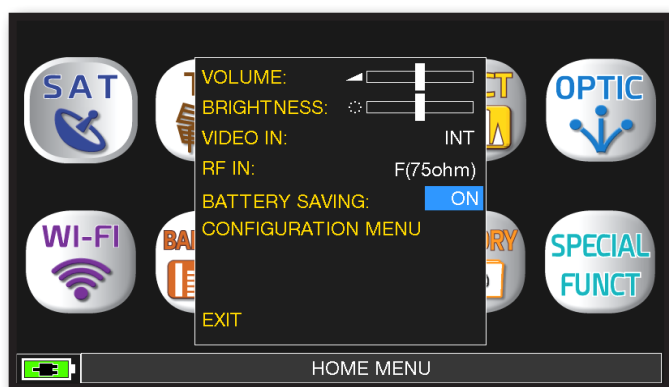

Choose "BATTERY SAVING" from the volume screen. In ON mode, if no key is pressed, after 30 seconds, the display brightness is reduced and after 5 minutes the meter automatically turns off. Press any key to temporarily reset the battery save mode.

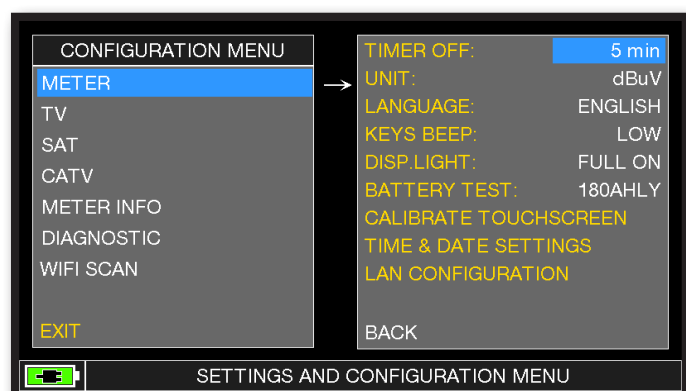

Touch "CONFIGURATION MENU" then "METER" in the volume screen and set the "TIMER OFF" value required. The meter will turn off after 5, 10, 15 or 30 minutes of inactivity. Press any key to interrupt the automatic turn-off.

# TOUCHSCREEN CALIBRATION

if the touchscreen does not respond to the commands, it may be necessary to calibrate:

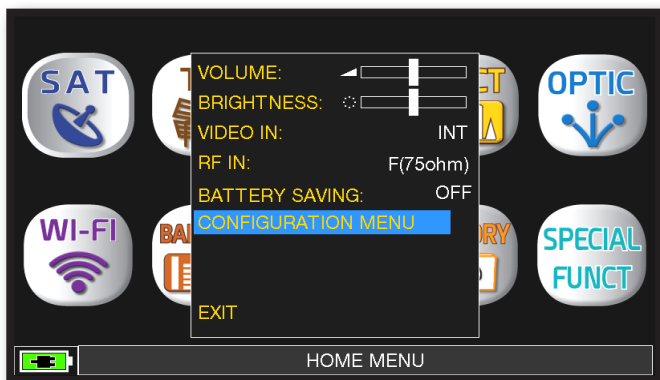

Touch "CONFIGURATION MENU"  
from the volume window;

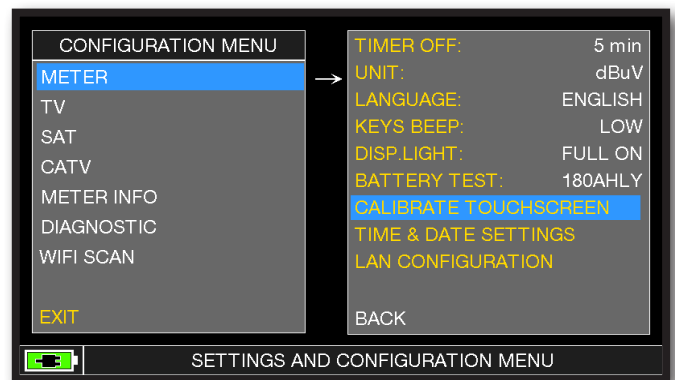

Touch "METER"  
then "CALIBRATE TOUCHSCREEN";



Touch the center of the squares that appear  
in the corners of the screen,  
repeat four times for every squares.

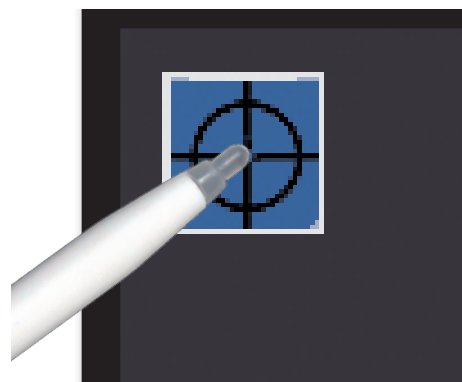

**NOTE:** use the pen and touch the the screen  
exactly in the center of the circle. if you do not  
carry out this procedure correctly the touch  
commands may be inaccurate.

# DISCOVERY

Identifies the modulation of a tuned TV channel in the TV master PLAN



Touch the "CONFIGURATION MENU" in the VOLUME window.

## TV MODE

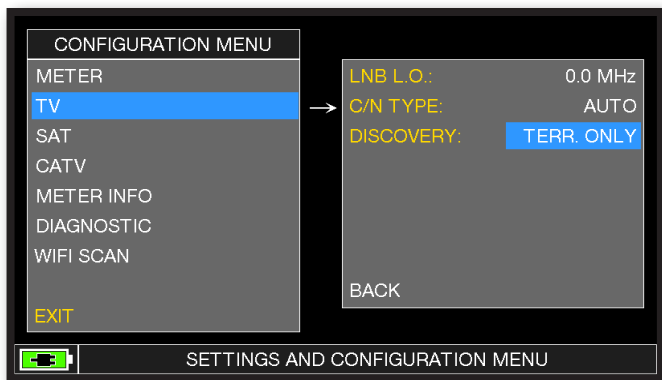

Touch "TV" and then "DISCOVERY" and set the identification mode:

- TERR ONLY
- TERR & CABLE

## CATV (CABLE) MODE

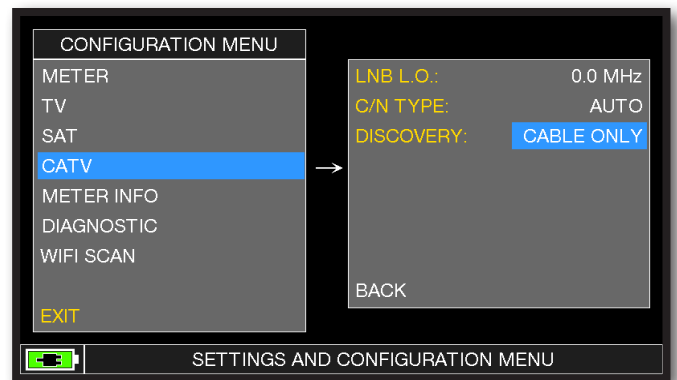

Touch "CATV" and then "DISCOVERY" and set the identification mode:

- CABLE ONLY
- TERR & CABLE

### NOTES:

- DISCOVERY mode is active only if the antenna cable is connected to the instrument
- DISCOVERY mode is not active if you use a manual (ManuMemory Mix) or automatic memory plan (Automemory TV)

# C/N TYPE

Set the measurement mode of the carrier noise ratio "C/N" (in band-out band).

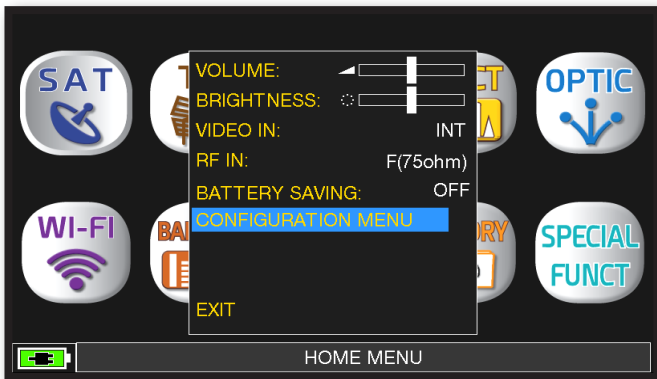

Touch 'CONFIGURATION MENU' from the volume screen.

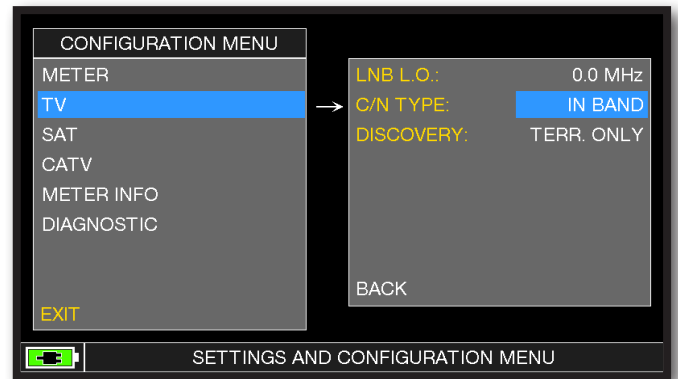

Touch "TV" then "C/N TYPE".

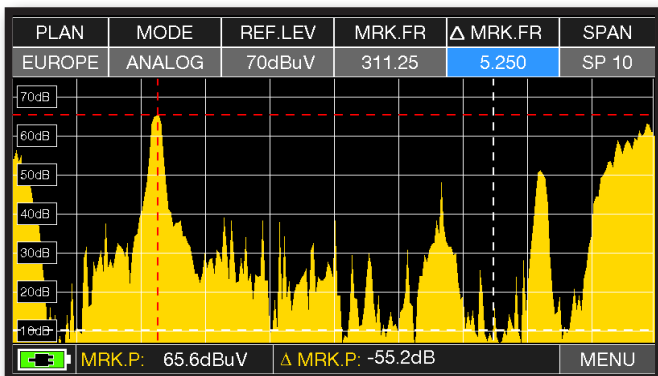

C/N measurement mode "IN BAND":  
the signal/noise ratio is measured between the signal level of the video carrier (signal/carrier, red marker) and the noise level, estimated in the band between the coloured subcarrier and the audio carrier (white marker).

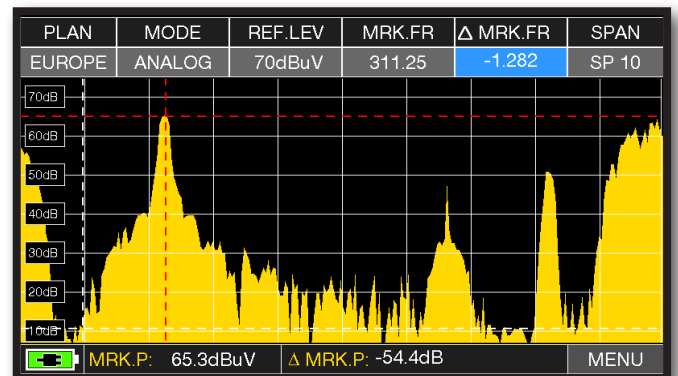

C/N measurement mode "OUTSIDE THE BAND":  
The signal/noise ratio is measured between the signal level of the video carrier (signal/carrier, red marker) and the noise level estimated in the guard band (-1.282 MHz from the video carrier, white marker).

**NOTE:** the "C/N TYPE" setup is available in TV and CATV mode.



# SCREEN SHOT

The "SCREEN SHOT" function allows you to directly save the TFT monitor screens in an external memory.



- Connect an external memory source (not provided) to the USB A socket.
- Set the instrument on the screen to be saved: Spectrum, Measurements, Constellation, Echoes etc.
- Press the SPECT (4" Screenshot) key for 4 seconds keys and wait for file to be saved: the instrument will make a series of beeps.
- Digit the file name and touch ENTER.

## N.B.:

- If the memory is not inserted correctly, or is not recognised, the following message will be shown: "PLEASE INSERT USB MASS STORAGE DEVICE".
- Full screen picture zooms can not be saved.
- the ENTER command is not active If the file name is already present in the external memory source.
- The files are saved in .bmp (bitmap) format.



# SAT MEASUREMENTS



Press the "HOME" key.

or



Touch "SAT", and then "PLAN" or use the encoder to obtain the Satellite list.

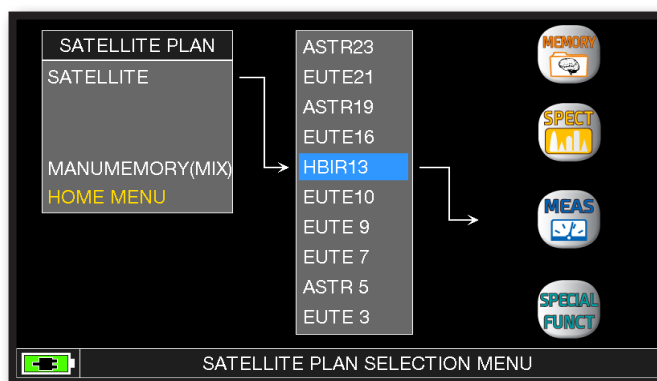

Touch directly the desired satellite, or use the encoder. At the end touch "MEAS" to make the measure or "SPECT" for visualize the spectrum.

## NOTE:

The chosen Satellite and Transponder will remain in memory also if you change mode (TV/CATV) or if you switch off the meter.

# DVB-S, DVB-S2 & S2M SAT MEASURES

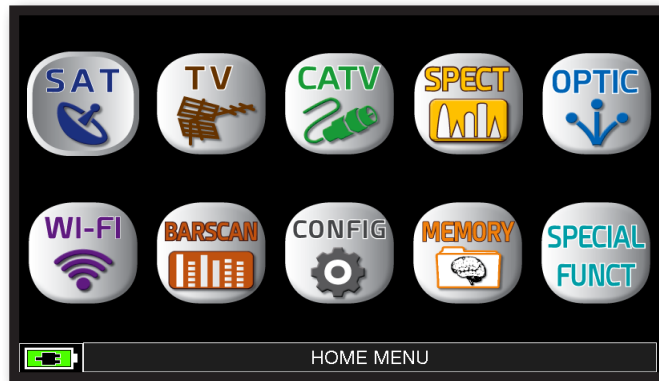

Press the "HOME" key.



Touch "SAT" and then "MEAS & PICT" or use the encoder.

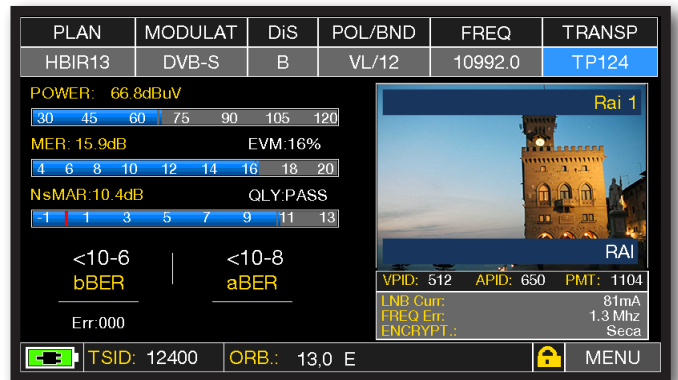

Main measures and image.

## RELATED FUNCTIONS



Press repeatedly to navigate into SAT measures screens: Measures, Constellation.



Press to enter in the spectrum.



# VISUALIZE NIT

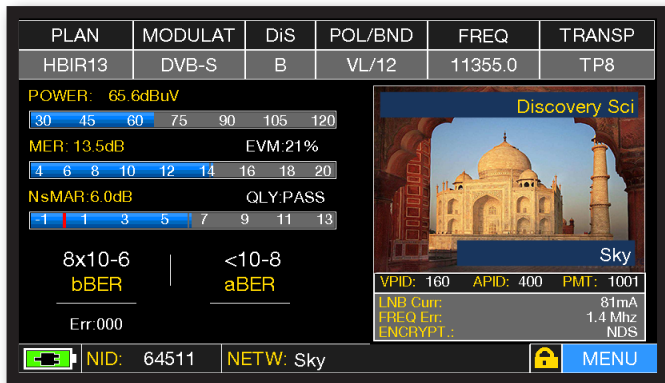

Touch "MENU" from the "MAIN MEASUREMENTS & PICTURES".

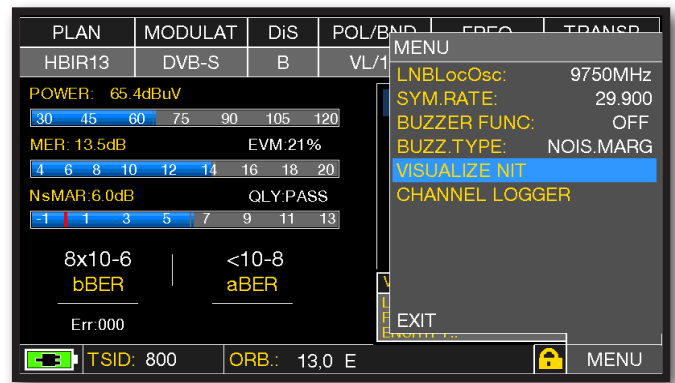

Touch "VISUALIZE NIT".

## Example 1:

NIT INFO VISUALIZATION					
FREQ	POL	SYM.RATE	MODE	TYPE	FEC
11842.0	vert	29900.00	DVB-S2	8PSK	3/4
12731.0	hor	29900.00	DVB-S	QPSK	5/6
11976.0	hor	29900.00	DVB-S	QPSK	5/6
12713.0	vert	29900.00	DVB-S	QPSK	5/6
12616.0	hor	29900.00	DVB-S	QPSK	5/6
12635.0	vert	29900.00	DVB-S	QPSK	5/6
12054.0	hor	29900.00	DVB-S	QPSK	5/6
12034.0	vert	29900.00	DVB-S	QPSK	5/6
11958.0	vert	27500.00	DVB-S	QPSK	3/4
11861.0	hor	29900.00	DVB-S	QPSK	5/6
12465.9	vert	29900.00	DVB-S	QPSK	5/6

"NIT INFO VISUALIZATION" referring to an HOTBIRD 13° East transponder

### NOTE:

The function VISUALIZE NIT is available also in TV & CATV mode

# CHANNEL MONITOR

The weekly application of SW CHANNEL MONITOR allow you to controll and register the trend of the main parameters of a digital signal over time (from 30 minutes to one week): TV, CATV & SAT. This application is indicated to resolv the reception problems which occur occasionally, it allow you also to measure, memorize and visualize (local or in remote) the digital signals parameters tested: DVB-S/T/C = Power, MER, ERROR, bBer, aBer; DVB-S2 / T2 / C2 = Power, MER, ERROR, aBer, Lber, PER, LDPC.

Every registered parameters is graphically represented on the display using differents colours for a easy identification.

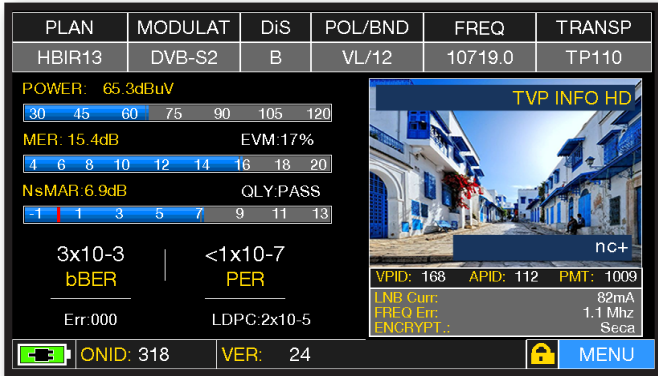

Touch "MENU" from MAIN MEASURES & IMAGES screen.

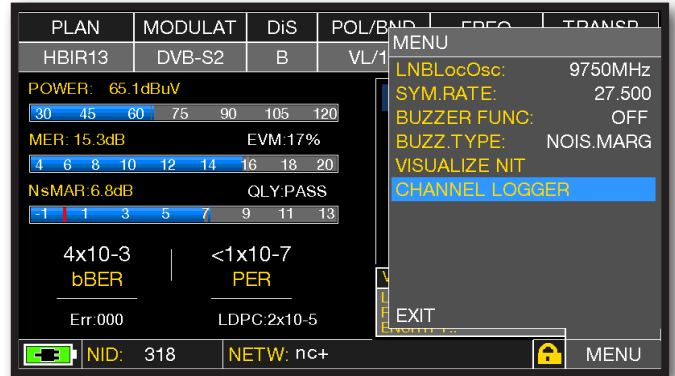

Touch "CHANNEL LOGGER".

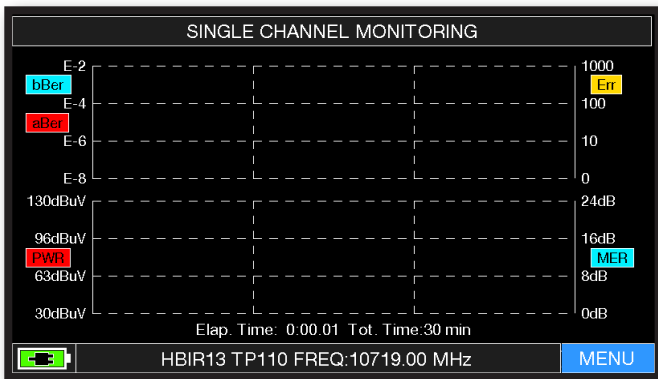

Touch "MENU".

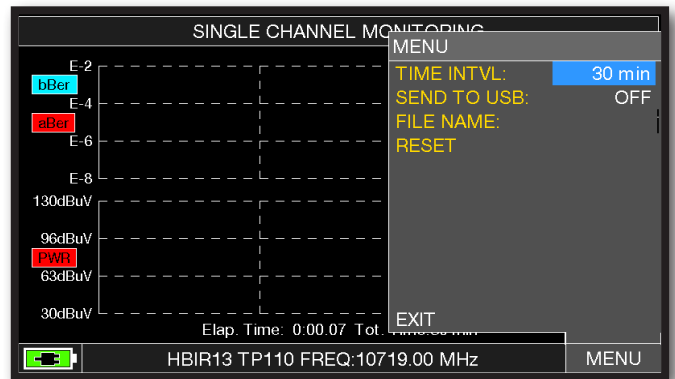

Select the time interval (TIME INTVL) and where you want to store the file, either in the meter's memory, or in the USB memory stick (send to USB-ON), with the relative file name (File name).

## Example 1:

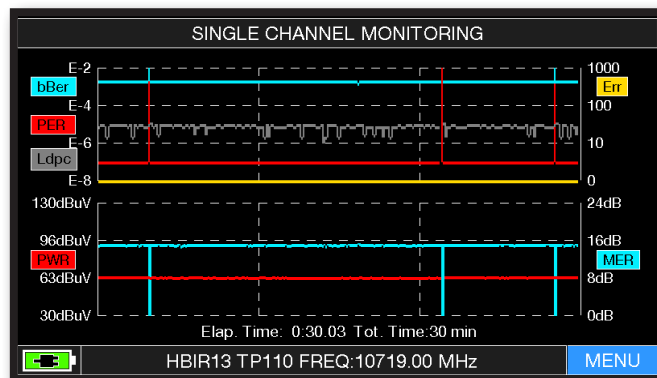

SINGLE CHANNEL MONITORING: 30 minutes.

**NOTE:** the Channel Monitor function is available also in TV and CATV mode.

# DVB-S2M SIGNAL: ISI SELECTION

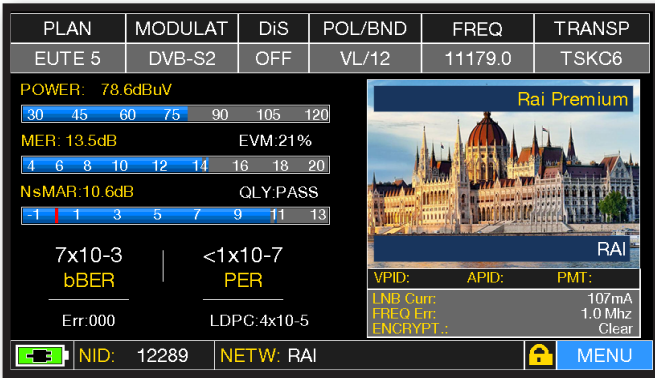

Touch "MENU" on the main measurements and picture screen

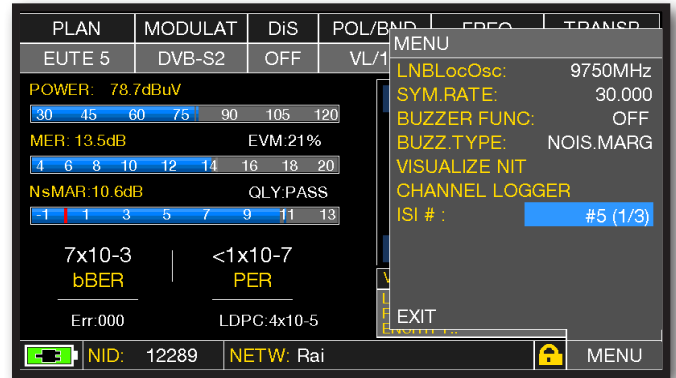

Touch "ISI #" and select the ISI (Transport Stream) required

# PLS CONFIGURATION

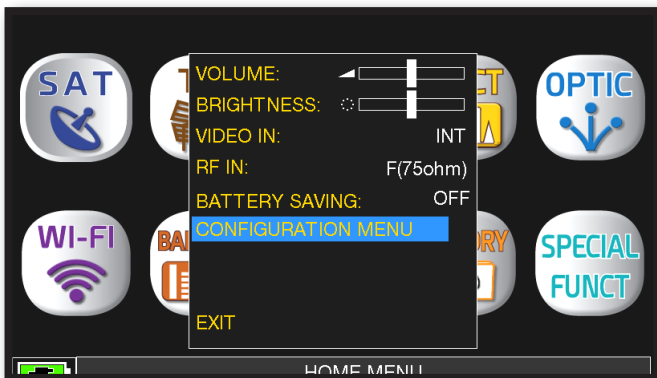

Touch "CONFIGURATION MENU" in the volume window

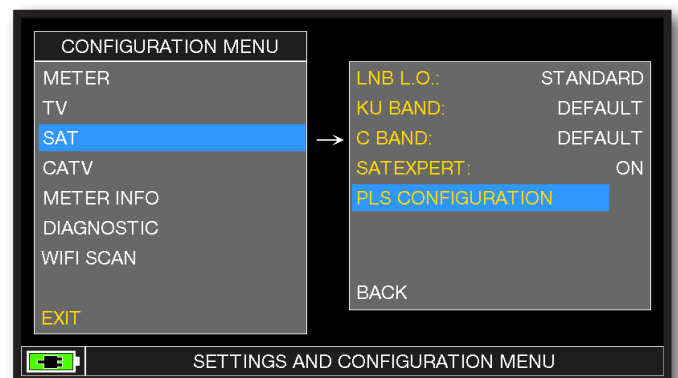

Touch "SAT" and select "PLS CONFIGURATION"

## Example 1:

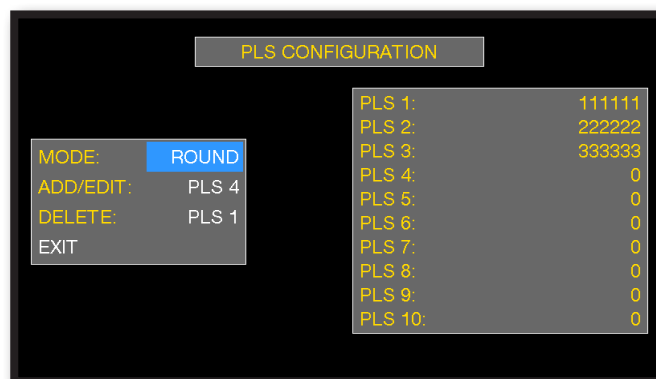

Select the PLS required and set the parameters

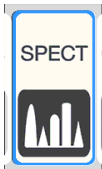

# SPECTRUM ANALYZER



Press the "HOME" key.



Touch "SAT" and then "SPECT" or use the encoder.

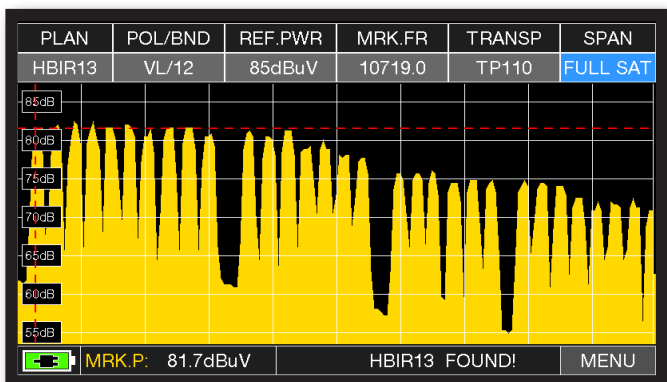

SAT SPAN FULL SAT Spectrum (from 930 to 2250 MHz).

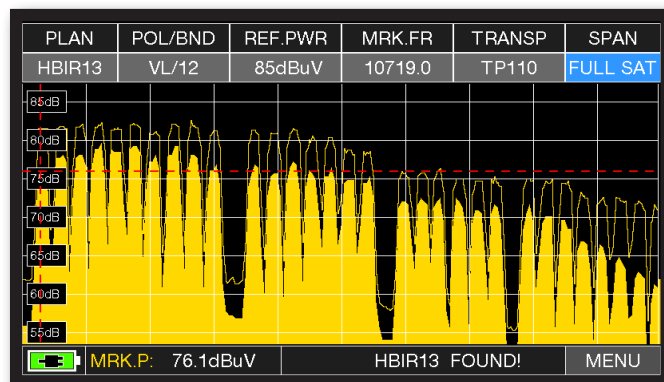

Press again the SPECT key to activate the "MAX HOLD" function.

Touch "SPAN" and rotate the encoder to select the SPAN value desired:  
10-20-50-100-200-500-FULL SAT-FULL EXT

### Example 1:

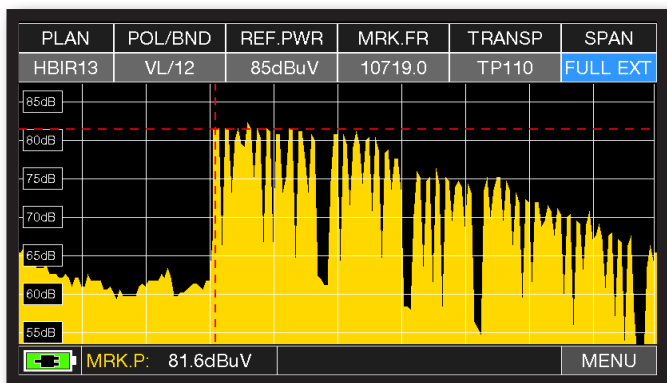

"SAT" spectrum SPAN FULL EXT (from 230 to 2610 MHz) with universal LNB.

### Example 2:

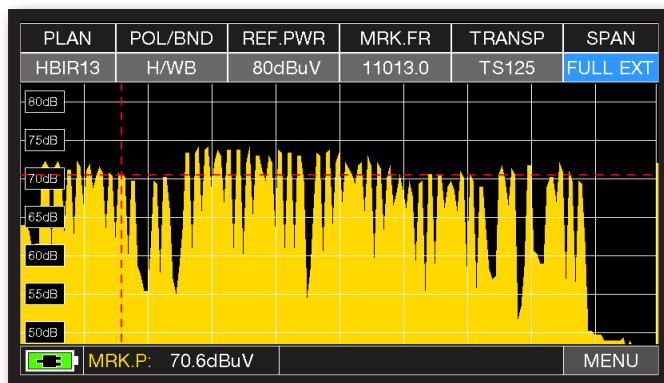

"SAT" spectrum SPAN FULL EXT (from 230 to 2610 MHz) with LNB WIDE BAND.

# RBW FILTER

The RBW (Resolution Bandwidth) filter function determines the bandwidth of the bandpass filter, which is used to generate the spectrum of the input signal (IF).

This bandpass filter works like a window: the smaller the bandwidth, the more detailed is the representation of the spectrum. However, a smaller value RBW provides a slower refresh rate of the spectrum.

You can choose (high resolution, slower refresh rate) between the RBW filter between a bandwidth of 1 MHz or 5 MHz (lower resolution, fast refresh rate).

## EXAMPLE 1:

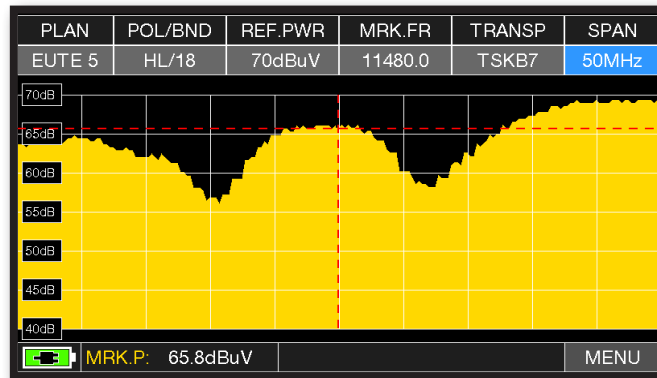

Visualization of an SCPC transponder with settings: "RBW FILTER 5 MHz" and "dB DIV 5dB" (Span 50 MHz)

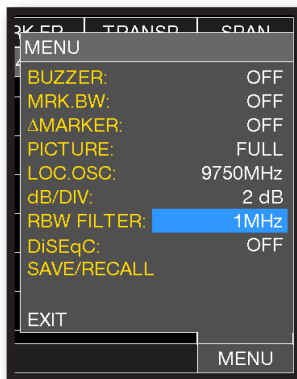

Touch "MENU&?" from the SAT SPECTRUM screen, select "dB DIV 2dB" and "RBW FILTER 1 MHz".

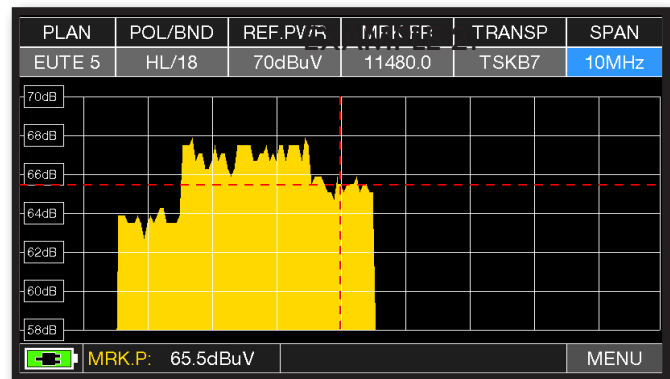

Visualization of a SAT SCPC transponder (SPAN 10 MHz).

**NOTE:** You can only select RBW filter in SAT mode.

# SAT EXPERT

The SATEXPERT SW function (guided satellite tracking function), is a valuable aid for a fast satellite antenna pointing to a wanted satellite.

Through text messages, which appear from time to time on the screen, the measuring instrument will indicate in which direction to move the satellite dish, to the east or to the west, until you reach the wanted satellite.

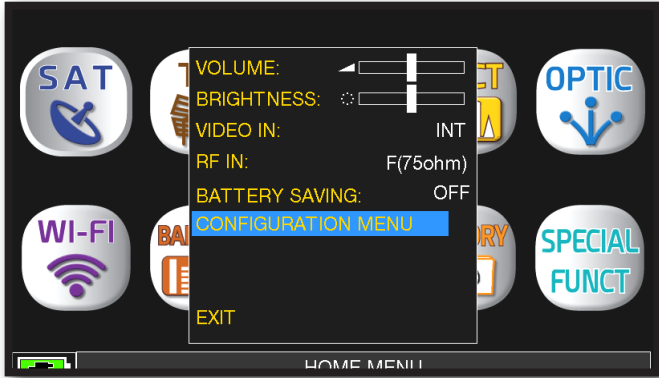

Touch "CONFIGURATION MENU" from the VOLUME screen

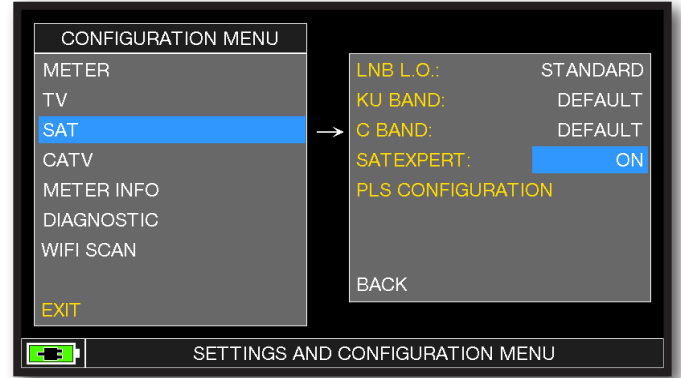

Touch "SAT", then in "SAT EXPERT" and select "ON"

In SAT mode, press the PLAN key and select the satellite to be pointed, for example HBIR 13. Press the SPECT key, touch "SPAN" and select "Satxpert".

Here you can find some examples:

## EXAMPLE 1:

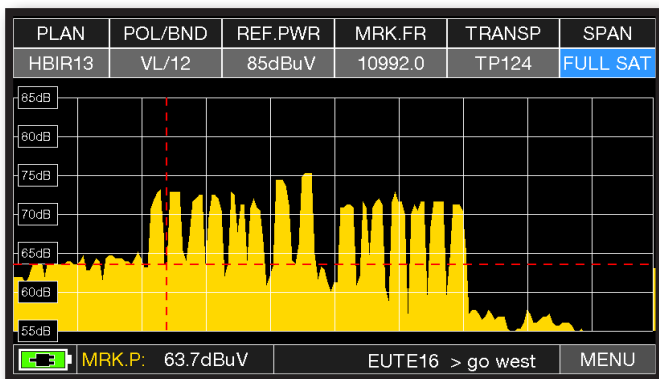

The satellite you have pointed is not correct. the lower part of the display shows the following information:  
**EUTE 16 > GO WEST**  
 (move the satellite dish west).

## EXAMPLE 2:

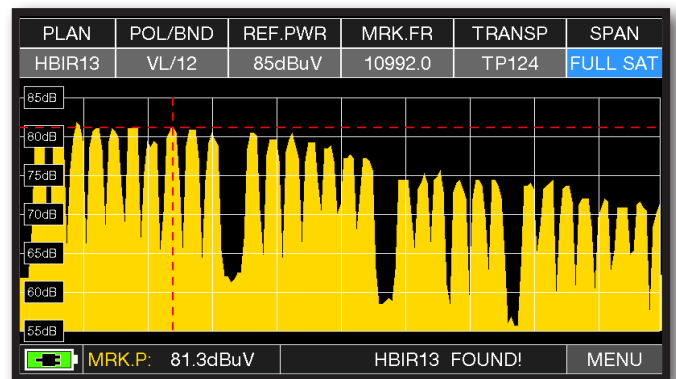

Satellite found. the lower part of the display shows the following information:  
**HBIR13 FOUND!**  
 (the satellite that has been pointed is correct)

### EXAMPLE 3:

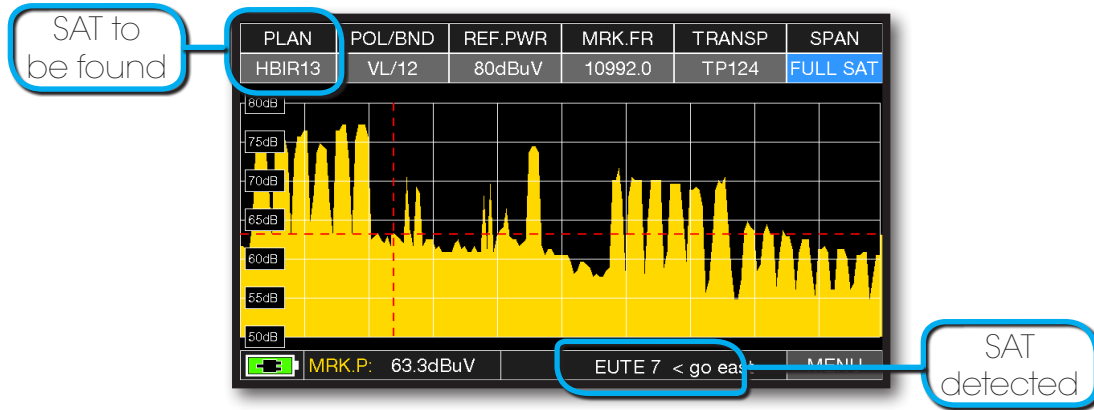

The pointed Satellite is not the correct one.  
The lower part of the display shows the following information:  
**EUTE7 < GO EAST** (move the satellite dish EAST).

**IMPORTANT:** The text messages that from time to time will appear on the screen of the instrument when moving the satellite dish to east or west, are bounded to the diameter of the used antenna: 60-80-90 cm etc.  
Therefore, using antennas with a small diameter, the messages related to some satellites may not be reported.

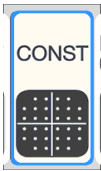

# CONSTELLATION ANALYSIS



Press the "HOME" key.



Touch "SAT" and then "CONST" or use the encoder.

## Example 1:

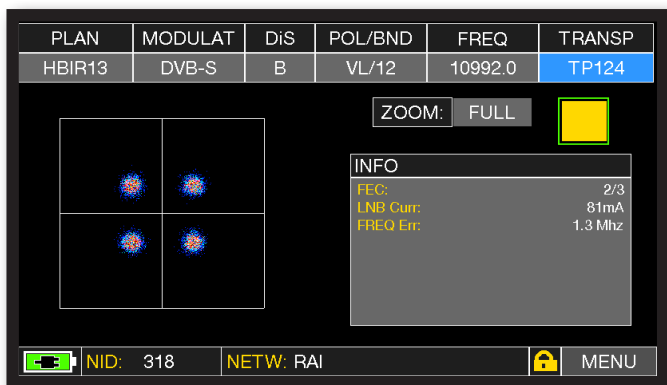

QPSK constellation.

## Example 2:

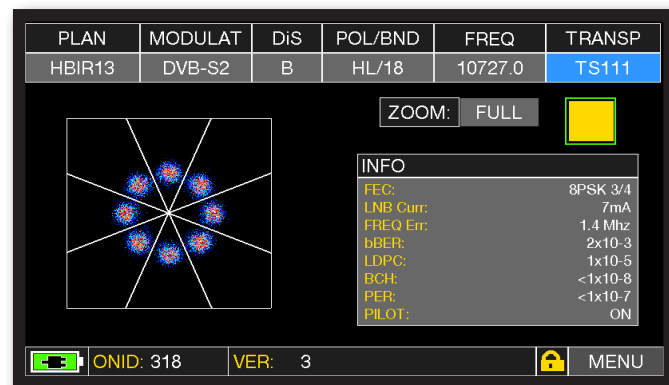

8PSK constellation.



Touch "FULL" and select the zone of constellation to enlarge.

# RELATED FUNCTIONS



Press repeatedly to navigate into SAT measures screens: Measures, Constellation.



Press to enter in the spectrum.





# SAT FINDER

The SAT FINDER function allow you to check the quality of 4 transponders simultaneity and to check the operation of the 4 LNB polarities.



Press the "HOME" key.



Touch "SAT" and then "SAT FINDER" or use the encoder.

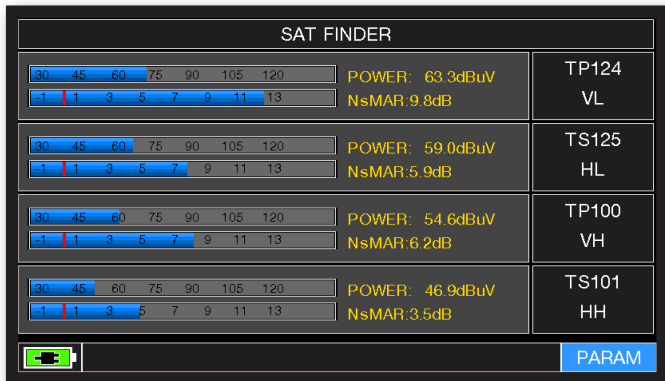

Satellite locked.

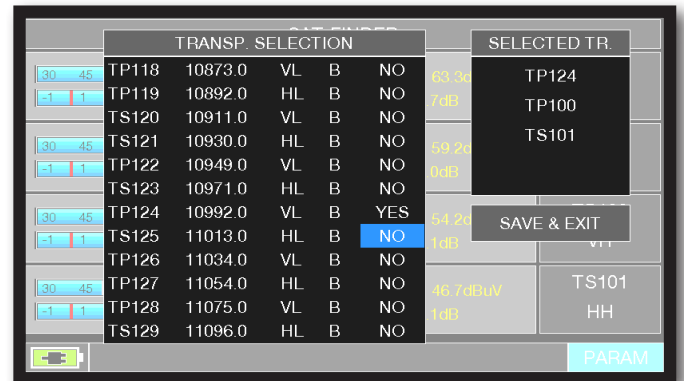

Touch "PARAM" to modify the transponders list.

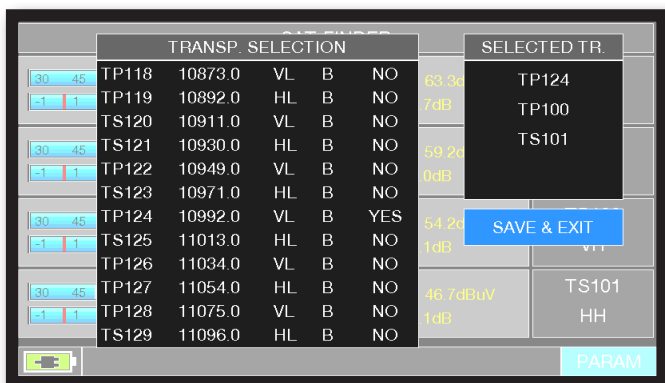

Touch the selected transponder, touch YES/NO to added or delete from list. Touch "SAVE & EXIT" to save and exit.

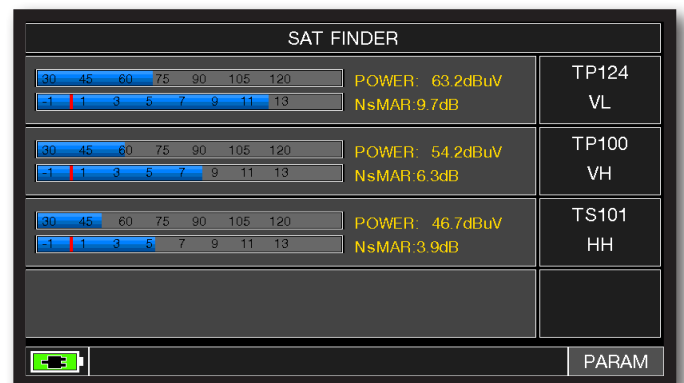

Satellite locked.

If the chosen satellite is found the buzzer will start, if this does not happen, continue looking for the right satellite. Optimize the dish alignment and skew to obtain the maximum NsMAR value (noise margin).

**NOTE:** For a proper use of the "SAT FINDER" function, verify the tuning parameters for all three transponders (frequency, polarity, band, and symbol rate) and the type of lnb you are using (universal or quatro)

Go to the [www.lyngsat.com](http://www.lyngsat.com) site for more information



# AZ/EL POINTING DATA



Press "HOME" key.



Touch "SAT" and then "AZ/EL".

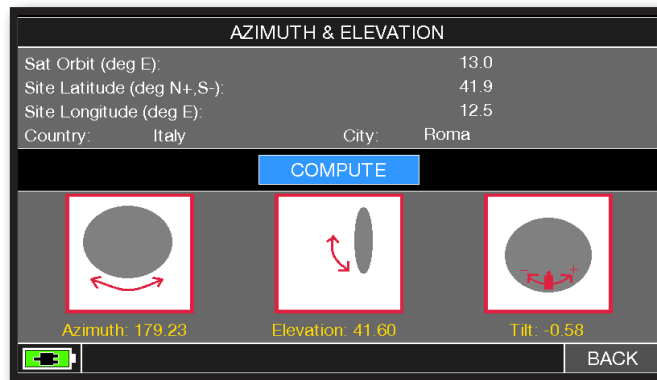

Calculation of the pointing data:

- Touch "SAT ORBIT" and set up the orbit position of the desired satellite, for example 13,0 EAST.
- Touch "COUNTRY" and select your Nation, for example Italy.
- Touch "CITY" and select your city, for example Roma.
- Touch "COMPUTE" to obtain the automatic calculation of pointing parameters: Azimuth, Elevation & Tilt.



# MEASURES WITH SCR LNB/MULTISWITCH



Touch the "HOME" key.



Touch "SAT" and then "SCR DCSS" or use the encoder.

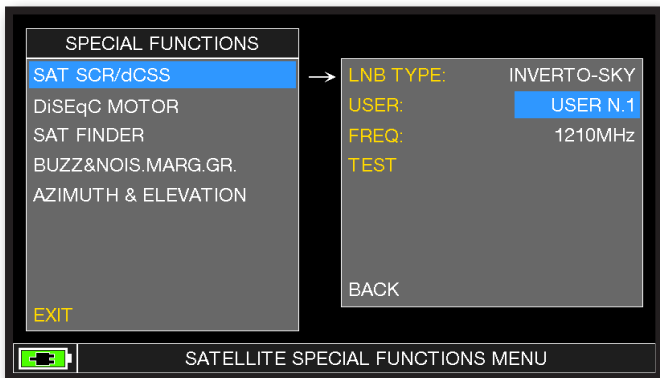

- Touch "LNB TYPE" and select the installed LNB/multiswitch model (see NOTE).
- Touch "USER" and select the user's number to test (user 1-4).
- Press "SPECT" to visualize the spectrum or "SAT" to make the measure.

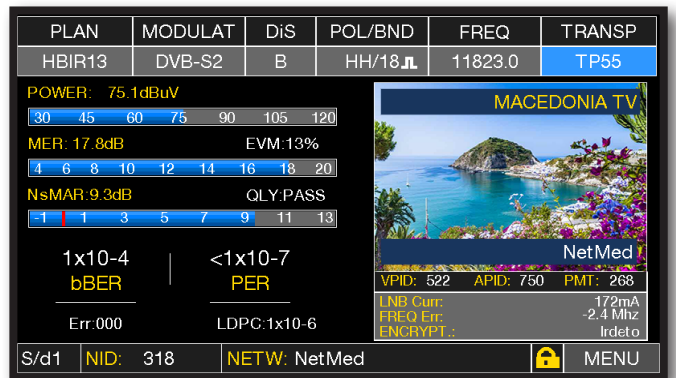

SCR measures.

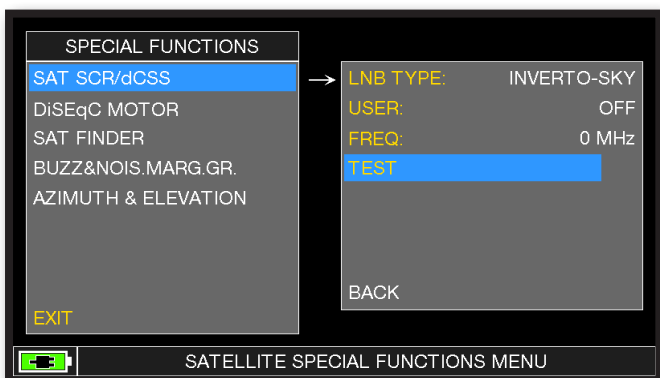

Or touch "TEST", in Spectrum mode, to perform a verify of the 8 exit frequencies (user 1-4) from LNB/multiswitch.

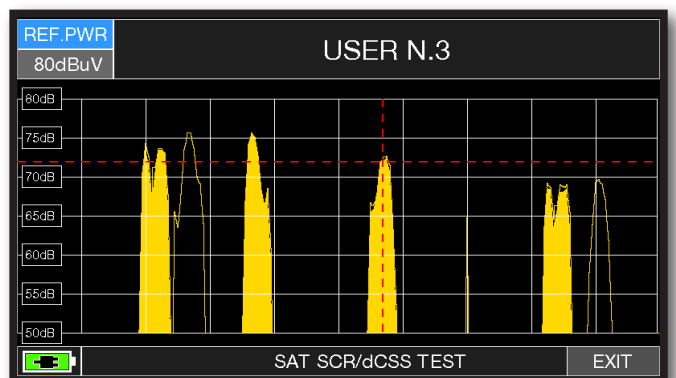

SCR test.

# LNB/MULTISWITCH dCSS MEASURES



Press the "HOME" key.



Touch "SAT" and then "SCR DCSS" or use the encoder.

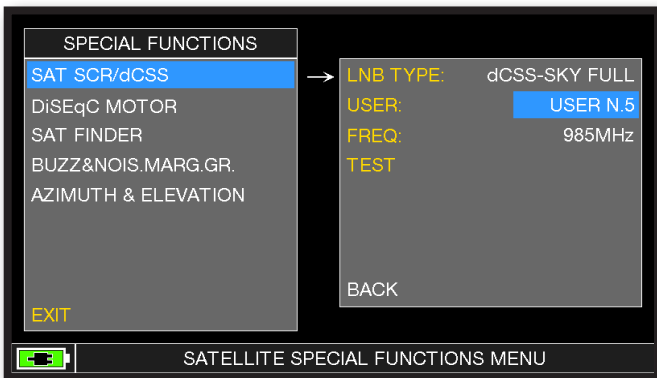

- Touch "LNB TYPE" and select the installed LNB/multiswitch model (see NOTE).
- Touch "USER" and select the user's number to test (user 5-16).
- Press "SPECT" to visualize the spectrum or "SAT" to make the measure.

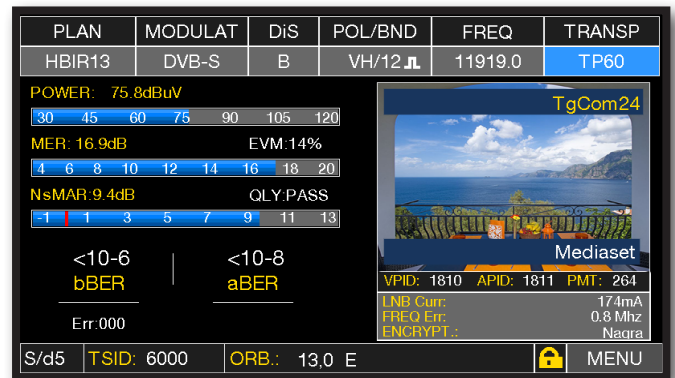

dCSS measures.

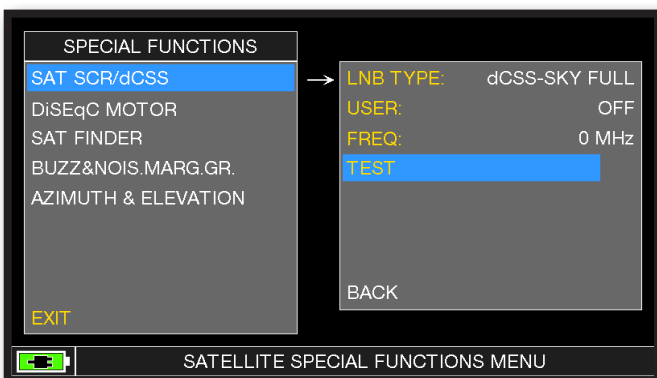

Or touch "TEST", in Spectrum mode, to perform a verify of the 8 exit frequencies (user 5-16) from LNB/multiswitch.

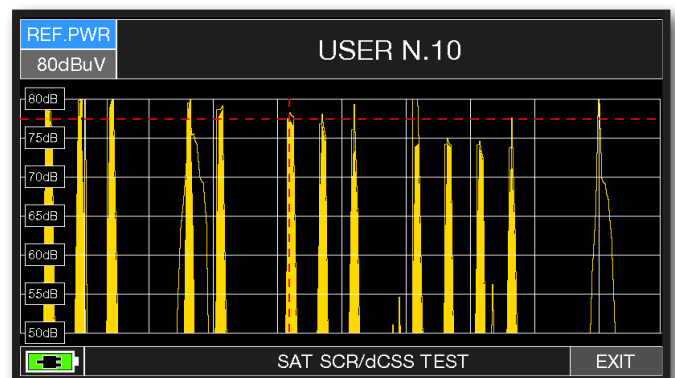

dCSS test.



# IMAGES VISUALIZATION & SERVICE CHOICE



Press "HOME" key.



Touch "SAT" and then "MPEG" or use the encoder.

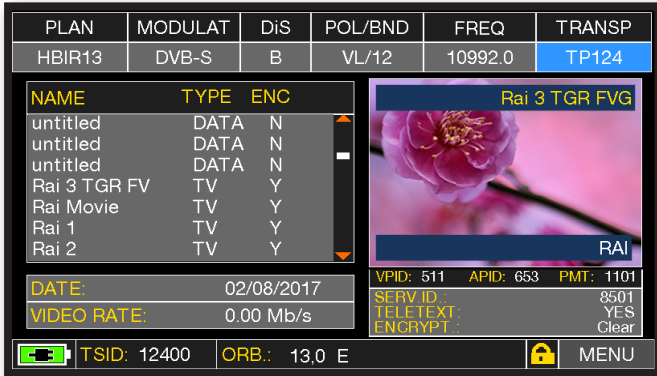

Images and MPEG service list.

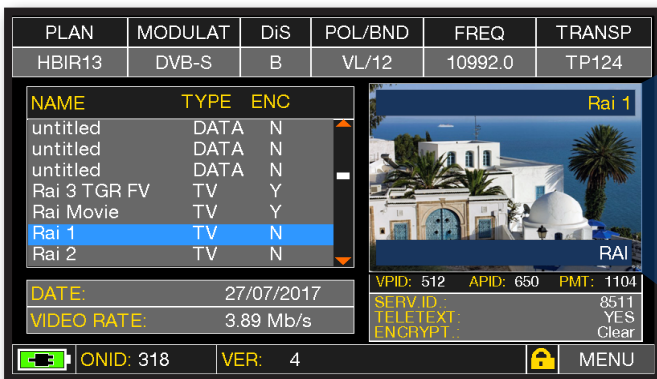
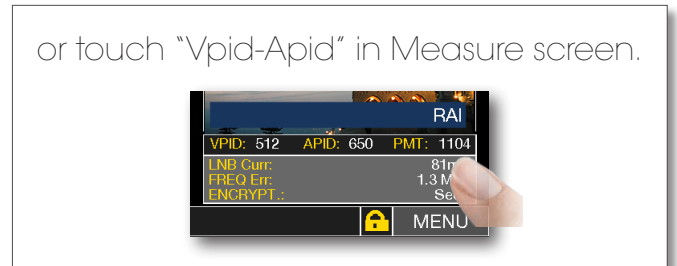
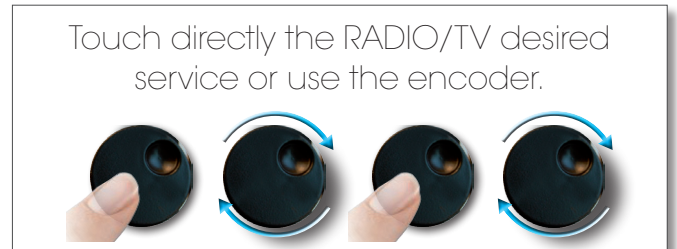

RADIO & TV service selection.



Touch the image to enlarge. Touch again to come back at the service list.



# TV MEASURE



Press the "HOME" key.



or



Touch "TV" and then "PLAN"  
or use the encoder to access  
at the TV canalizations list.

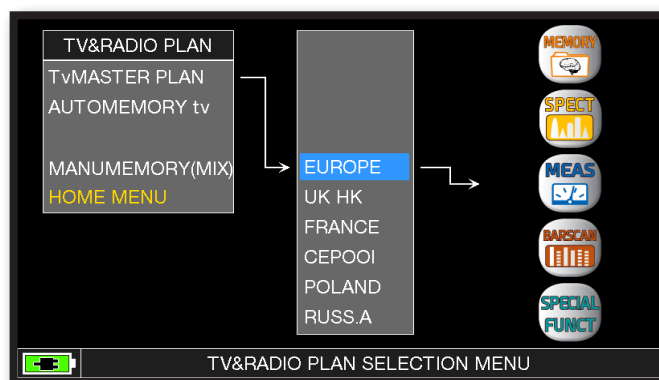

Touch directly the decided canalization  
or use the encoder. At the end touch  
"MEAS" to make the measure or "SPECT"  
for visualize the spectrum.

## NOTE:

The chosen canalization and channel will remain in memory also if you change mode (CATV/SAT) or if you switch off the meter.



# DIGITAL TV MEASUREMENT DISPLAYS DVB-T & DVB-T2 M-PLP



Press the "HOME" key.



Touch "TV" and then "MEAS & PICT" or use the encoder.

PLAN	MODULAT	BW	DC@RF	FREQ	CHAN
EUROPE	DVBT&H	8	OFF	698.00	49

POWER: 74.1dBuV  
 30 45 60 75 90 105 120  
 MER: 35.7dB SNR: 39dB  
 8 12 16 20 24 28 32 36 40  
 NsMAR: 15.0dB QLY: PASS  
 -1 3 7 11 15 19 23

<10-6 bBER | <10-8 aBER  
 Err: 000

NID: 12289 NETW: Mediaset4 MENU

VPID: 1630 APID: 1631 PMT: 204  
 CARRIER: 8K DVB-T  
 CONST: 64QAM  
 ENCRYPT: Seca

Main menu and image.

## RELATED FUNCTIONS



Press repeatedly to navigate into TV measures screens: Measures, Constellation.



Press to enter in the spectrum.

# DVB-T2 SIGNAL: PLP SELECTION

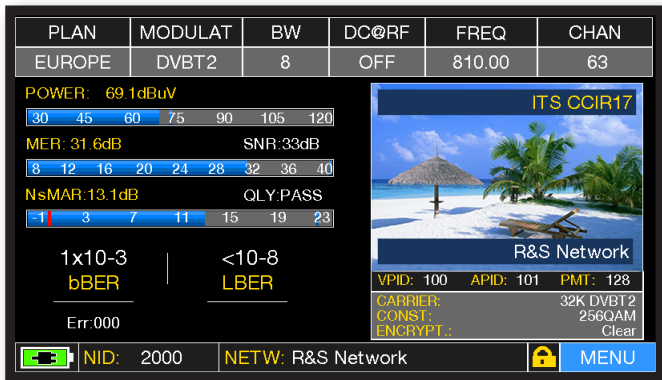

Touch "MENU" from MAIN MEASURES & IMAGES screen.

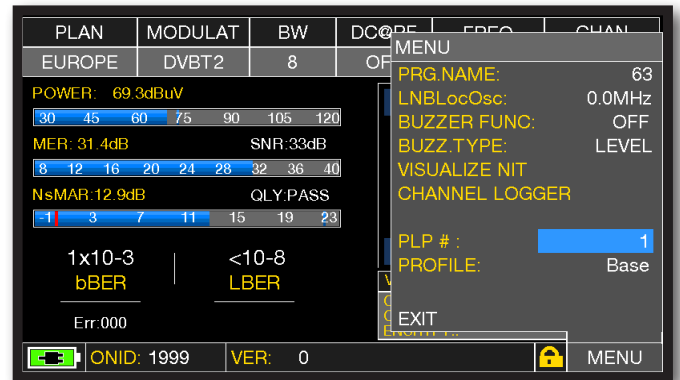

Touch "PLP #" and select the desired PLP (transport Stream)

# DVB-T2 SIGNAL: PROFILE SELECTION

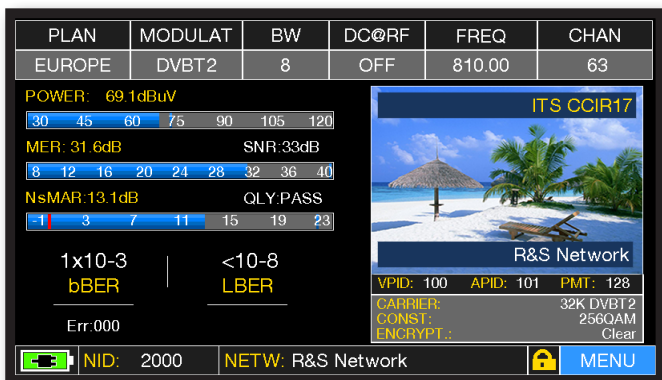

Touch "MENU" from MAIN MEASURES & IMAGES screen.

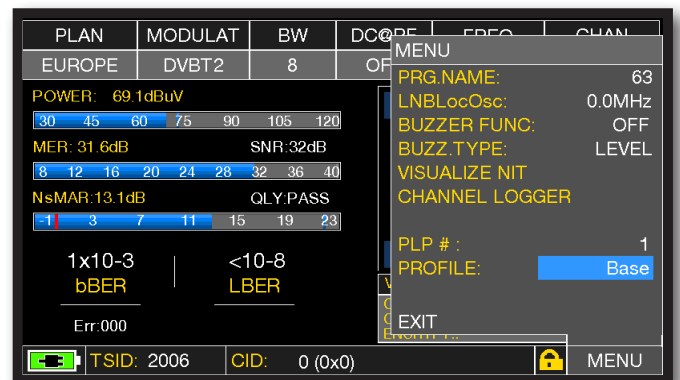

Touch "PROFILE" and select the desired profile: "Basic" or "Lite".





# SPECTRUM ANALYZER



Press the "HOME" key.



Touch "TV" and then "SPECT" or use the encoder.

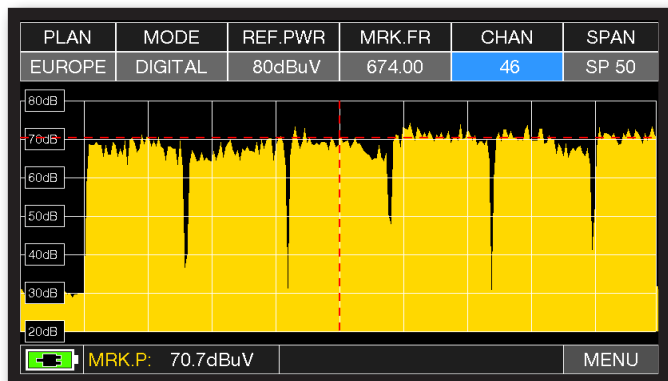

TV spectrum SPAN 50 MHz

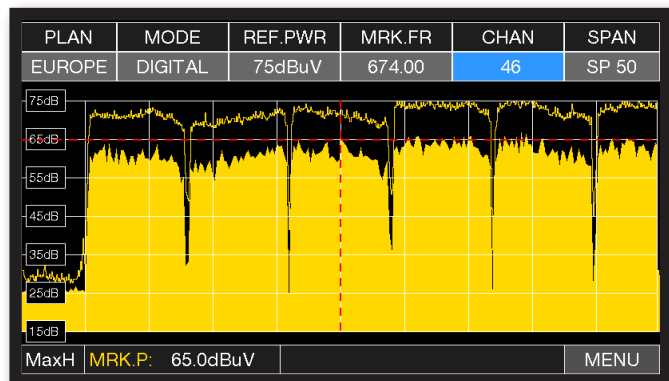

Press again to spectrum key to activate the "MAX HOLD" function.

Touch "SPAN" and rotate the encoder to select the desired SPAN value:  
1-2-5-7-10-20-50-100-200-500-FULL-UHF VHF

*Example 1:*

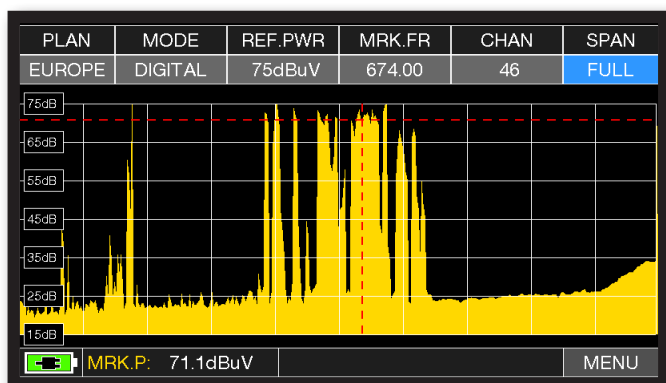

"TV" SPAN FULL spectrum (from 5 to 1.250 MHz).

*Example 2:*

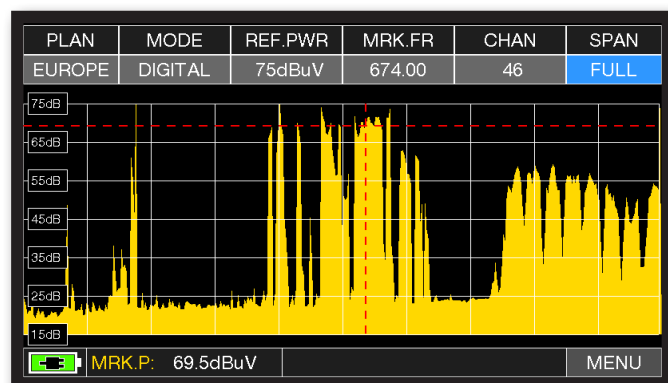

TV SPAN FULL spectrum with mixed channels SAT signals (from 5 to 1.250 MHz).

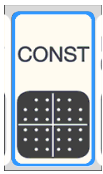

# CONSTELLATION ANALYSIS



Press the "HOME" key.



Touch "TV" and the "CONST" or use the encoder.

## Example 1:

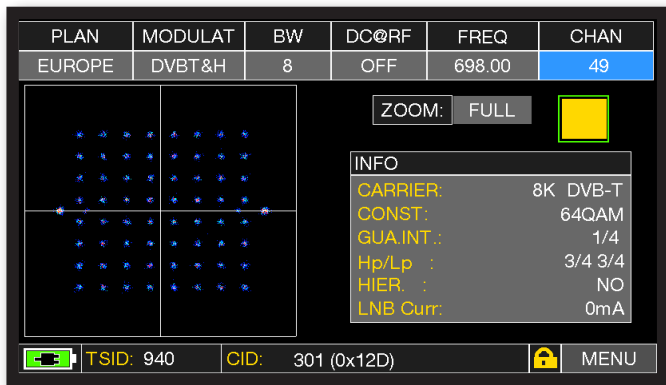

Constellation DVB-T.

## Example 2:

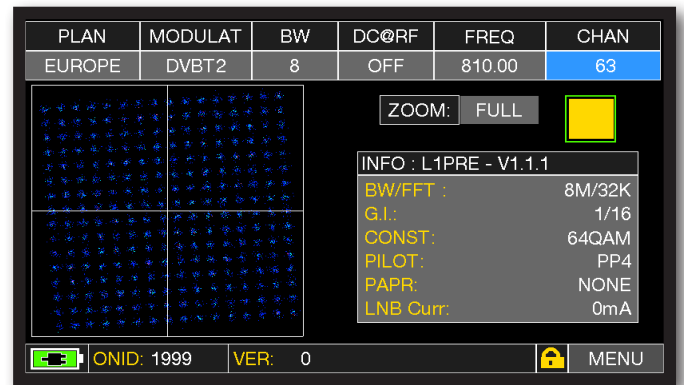

Constellation DVB-T2.



Touch "FULL" and select the box of constellation to enlarge.

## RELATED FUNCTIONS



Press repeatedly to navigate into TV measures screens: Measures, Constellation, echoes, MER vs CARRIER



Press to enter in the spectrum.

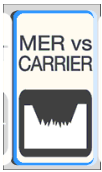

# MER VS CARRIER MEASUREMENT

The MER vs CARRIER measure allow to make analysis of the trend MER for single COFDM carriers which make up a signal DVB-T or DVB-T2.



Press the "HOME" key.



Touch "TV" and then "MER vs CARRIER" or use the encoder.

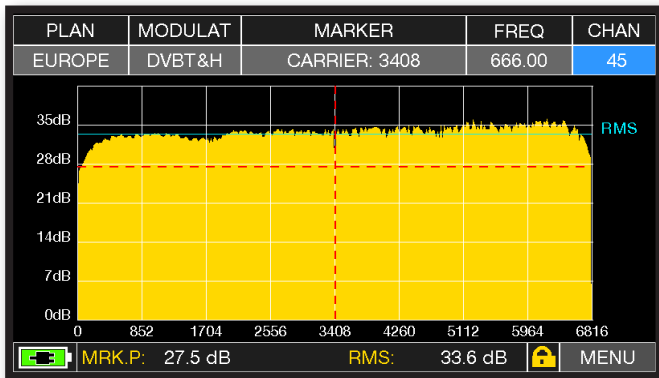

MER vs CARRIER: visualization mode "VIS. TYPE: NORMAL" & "PICTURE: FULL"

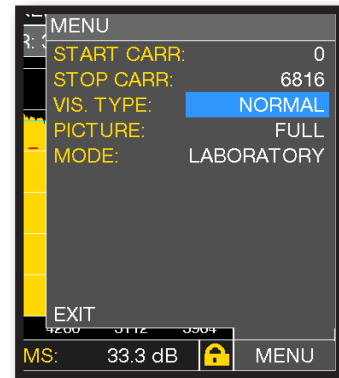

Touch "MENU & ?" to obtain different visualization modes.

Example 1:

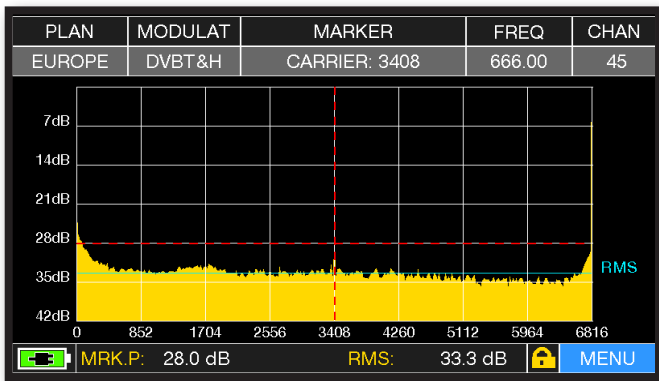

MER vs CARRIER : visualization mode "VIS. TYPE: REVERSE" & "PICTURE: FULL"

Example 2:

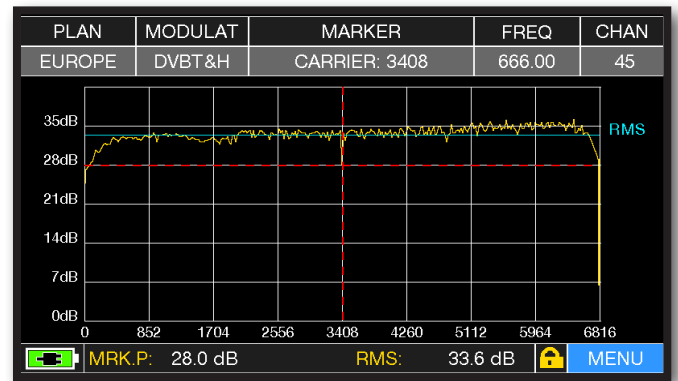

MER vs CARRIER : visualization mode "VIS. TYPE: NORMAL" & "PICTURE: CONTOURS".

Example 3:

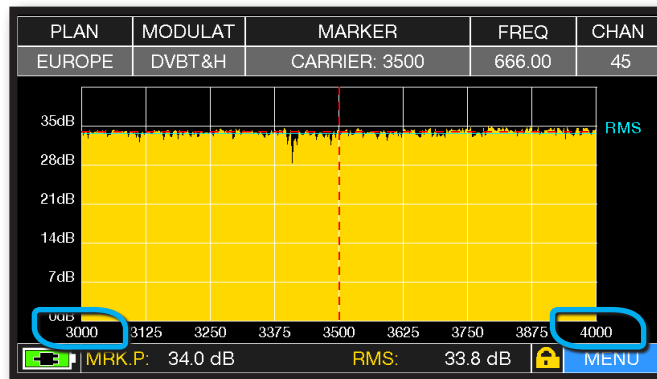

MER vs CARRIER: visualization mode "VIS. TYPE: NORMAL", "PICTURE: FULL" & "START/STOP CARR from 3000 to 4000".

## RELATED FUNCTIONS



Press repeatedly to navigate into TV measures screens: Measures, Constellation, echoes, MER vs CARRIER.



Press to enter in the spectrum.

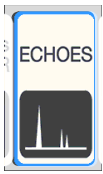

# ECHOES ANALYSIS



Press the "HOME" key.



Touch "TV" and then "ECHOES" or use the encoder.

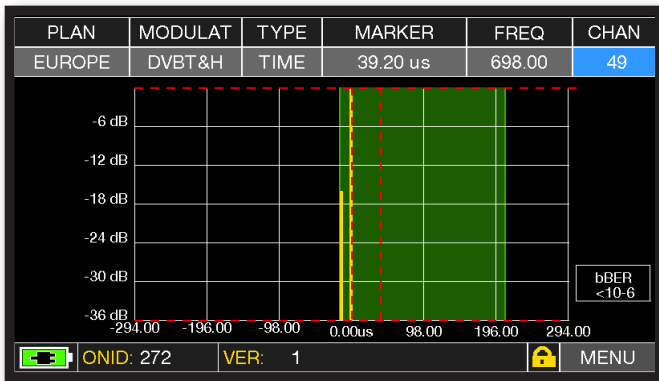

Impulse response (echo).

Touch "TYPE"

TYPE  
TIME

and select the echoes visualization mode:

TYPE  
DIST

TYPE  
TIME

DISTANCE or TIME

# MICROECHOES VISUALIZATION

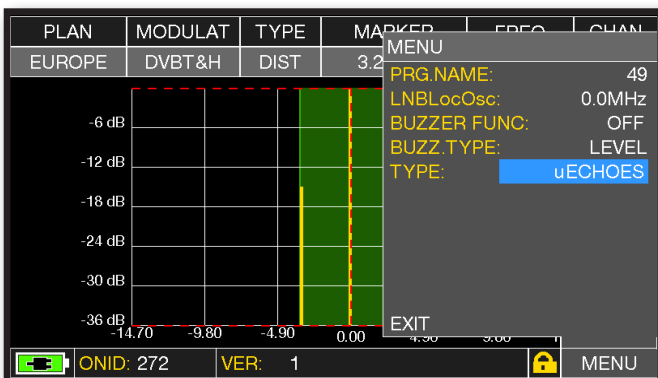

Touch "MENU", than "TYPE" and select "uECHOES".

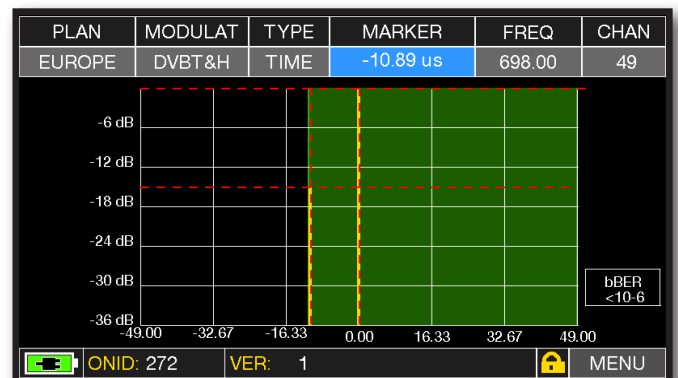

MicroEchoes visualization, touch the Marker and rotate the encoder to select the ECHOES.

**NOTE:** Other echo visualization modes are available in the "TYPE" menu

# ECHO & MICROECHO MEASUREMENT in "SFN" TV NETWORKS

## HOW TO REDUCE INTERFERENCES IN "SFN" NETWORKS

The analogue TV switch off is finish in Europe. Some countries, such as Spain and Italy, have decided to install digital TV "SFN" (Single Frequency Networks), in other words a national television broadcaster has the same frequency/channel all over the country. This provides a fantastic opportunity, but also means that in areas between two cells, it is possible to receive the same signals from more than one transmitter.

If the "SFN" network has been designed well, the SFN signals' slight propagation delay (which we will call "echoes"), coming from the different distances in which the transmitters are situated, becomes absorbed in the invaluable GUARD INTERVAL function, present in the DVB-T & T2 (COFDM) modulation and consequently there will not be any reception problems. In any case, experience over the last few years has shown us that reality is different to theory, especially when there are many local television networks that could generate many interferences.

You could therefore encounter the unpleasant experience of receiving a signal with good power, but that cannot show any pictures and not be able to establish the cause of the fault. In this case it is indispensable to measure the IMPULSE RESPONSE in real time, to measure the echo's delay or advance compared to the main signal. **When changing direction and position of the antenna it is possible to optimize reception intuitively, by maximising the power of the main signal and minimize the power of interference echoes, also at the expense of the channel power.**

Once again Rover Instruments is the first company to supply meters for TV installers, that can measure up to 16 ECHOES and PRE-ECHOES in real time. ROVER meters allow you to see ECHOES, measure the power and the delay in  $\mu$ S and the distance of the interfering broadcaster in Km. There are currently very few meters that allow you to measure ECHOES and PRE-ECHOES, in real time and at a distance of up to 75 Km, higher than the maximum amplitude possible with the GUARD INTERVAL and above all that can highlight, using the green mask, the useful reception area, in other words within the guard interval.

The width of the GUARD INTERVAL varies according to the modulation parameters: consult the table below to find the width of the GUARD INTERVAL and all the possible DVB-T configurations.

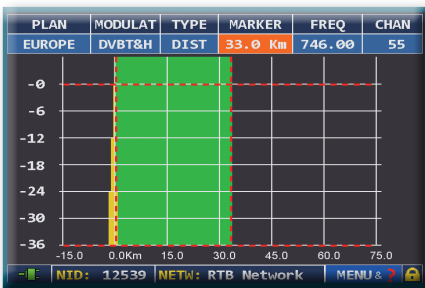

**Fig. 1:**  
**OPTIMUM RECEPTION:\***  
no ECHO present either outside or inside the guard interval mask (green area)

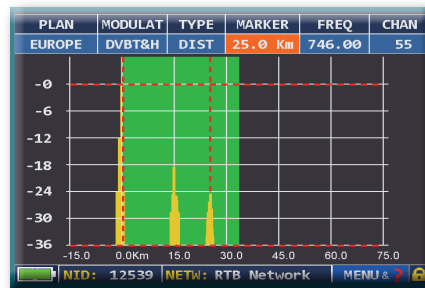

**Fig. 2:**  
**GOOD RECEPTION:\*** 2 ECHOES present, but within the guard interval mask (green area) coming from a distance of:  
1st echo: 15 Km, the same as a 50  $\mu$ s delay  
2nd echo: 25 Km, the same as a 83  $\mu$ s delay

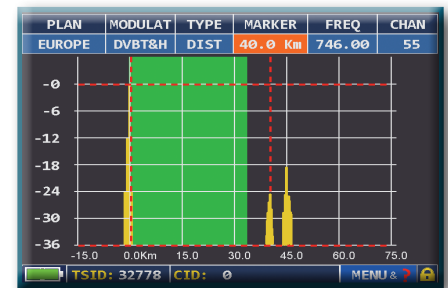

**Fig. 3:**  
**MARGINAL RECEPTION (or IMPOSSIBLE):\*** 2 ECHOES present outside the guard interval mask (green area), coming from a distance of:  
1st echo: 40 Km, the same as a 133  $\mu$ s delay  
2nd echo: 45 Km, the same as a 150  $\mu$ s delay

N.B.\* Valid examples for a DVB-T OFDM 8k signal with an 8 MHz Bandwidth and a 1/8 Guard Interval, this data is shown on ROVER meters to the right of the Constellation, see below Fig. 4.



**Fig. 4:**  
**DVB-T-64Q CONSTELLATION:**  
The table to the right shows all the received modulation parameters

### TEMPORAL GUARD INTERVAL WIDTH

(already automatically highlighted by the GREEN mask)

DVB-T 2.000 carriers (2K DVB-T)				
GUARD INTERVAL	1/4	1/8	1/16	1/32
max time (microsecondi)	56	28	14	7
max distance (Km)	16.8	8.4	4.2	2.1

DVB-T 8.000 carriers (8K DVB-T)				
GUARD INTERVAL	1/4	1/8	1/16	1/32
max time (microsecondi)	224	112	56	28
max distance (Km)	67.2	33.6	16.8	8.4



# IMAGES VISUALIZATION & SERVICE CHOICE



Press "HOME" key.



Touch "TV" and then "MPEG" or use the encoder.

PLAN	MODULAT	BW	DC@RF	FREQ	CHAN
EUROPE	DVBT&H	8	OFF	602.00	37
NAME	TYPE	ENC	 <p>R101 TV</p> <p>La3</p> <p>VPID: 610 APID: 611 PMT: 201 SERV ID: 8101 TELETEXT: YES ENCRYPT: Clear</p>		
105 TV	TV	N 157			
R101 TV	TV	N 167			
Radio R101	RADIO	N 771			
Canale5 HD	TV-HD	N 505			
Italia1 HD	TV-HD	N 506			
Premium Crim	TV-HD	Y 313	<p>DATE: 28/07/2017</p>		
Premium Acti	TV-HD	Y 311	<p>VIDEO RATE: 1.50 Mb/s</p>		
NID: 12289		NETW: La3		MENU	

Images and MPEG service list.

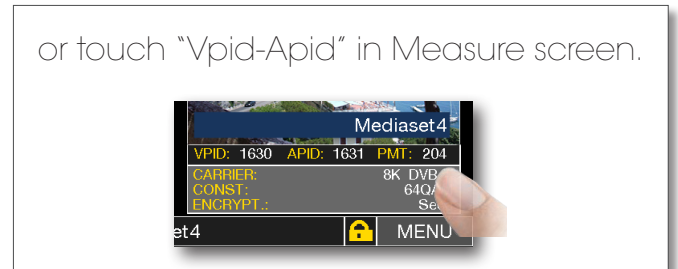

PLAN	MODULAT	BW	DC@RF	FREQ	CHAN
EUROPE	DVBT&H	8	OFF	602.00	37
NAME	TYPE	ENC	 <p>Italia1 HD</p> <p>La3</p> <p>VPID: 2740 APID: 2743 PMT: 276 SERV ID: 8106 TELETEXT: YES ENCRYPT: Clear</p>		
105 TV	TV	N 157			
R101 TV	TV	N 167			
Radio R101	RADIO	N 771			
Canale5 HD	TV-HD	N 505			
Italia1 HD	TV-HD	N 506			
Premium Crim	TV-HD	Y 313	<p>DATE: 28/07/2017</p>		
Premium Acti	TV-HD	Y 311	<p>VIDEO RATE: 4.17 Mb/s</p>		
TSID: 810		CID: 301 (0x12D)		MENU	

RADIO & TV service selection.



Touch the image to enlarge. Touch again to come back at the service list.

## RELATED FUNCTIONS



Press repeatedly to navigate into TV measures screens: Measures, Constellation, echoes, MER vs CARRIER.



Press to enter in the spectrum.

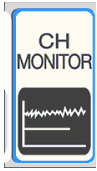

# CHANNEL MONITOR

The weekly application of SW CHANNEL MONITOR allow you to control and register the trend of the main parameters of a digital signal over time (from 30 minutes to one week): TV, CATV & SAT. This application is indicated to resolve the reception problems which occur occasionally, it allow you also to measure, memorize and visualize (local or in remote) the digital signals parameters tested: DVB-S/T/C = Power, MER, ERROR, bBer, aBer; DVB-S2 / T2 / C2 = Power, MER, ERROR, aBer, Lber, PER, LDCCP.

Every registered parameters is graphically represented on the display using different colours for a easy identification.



Press the "HOME" key.



Touch "TV" and then "CH MONITOR" or use the encoder.

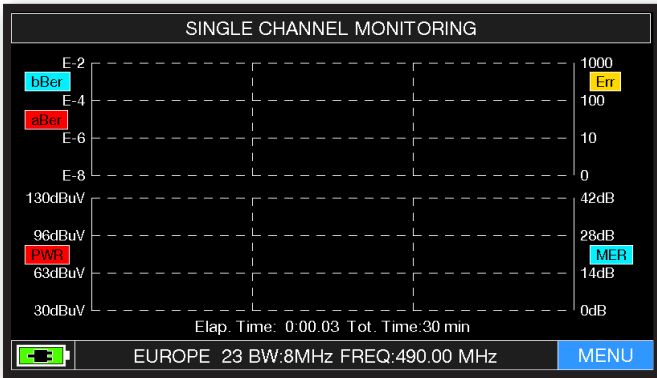

Touch "MENU"

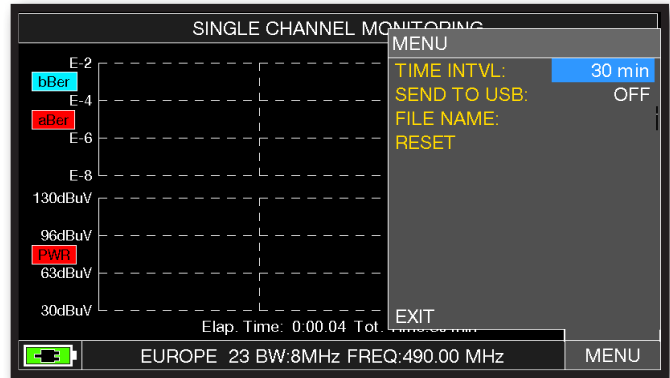

Select the time interval (TIME INTVL) and where you want to store the file, either in the meter's memory, or in the USB memory stick (send to USB-ON), with the relative file name (File name).

## Example 1:

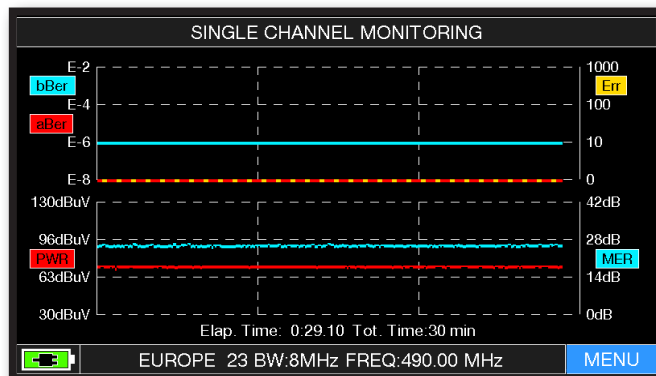

SINGLE CHANNEL MONITORING: 30 minutes.

**NOTE:** the Channel Monitor function is available also in CATV and SAT mode.





# CATV MEASURES



Press the "HOME" key.



o  
r



Touch "CATV" and then "PLAN" or use the encoder to access at the CATV canalizations list.

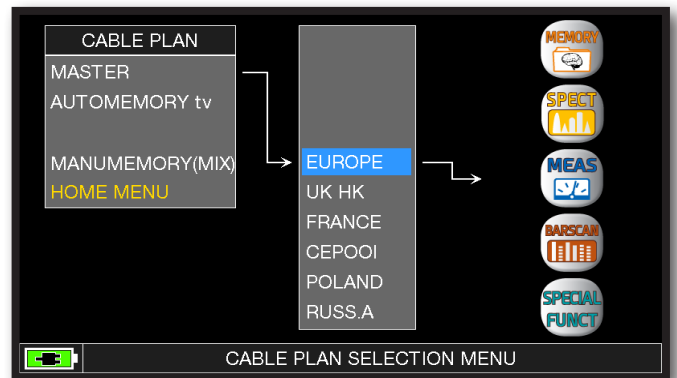

Touch directly the decided canalization or use the encoder. At the end touch "MEAS" to make the measure or "SPECT" for visualize the spectrum.

## NOTE:

The chosen canalization and channel will remain in memory also if you change mode (TV/SAT) or if you switch off the meter.



# DIGITAL DVB-C & DVB-C2 MEASURES (opt.)



Press the "HOME" key.



Touch "CATV" and then "MEAS & PICT" or use the encoder.

PLAN	MODULAT	CONST	DC@RF	FREQ	CHAN
EUROPE	DVB-C	QAM64	OFF	306.00	s21

POWER: 78.7dBuV  
 30 45 60 75 90 105 120  
 MER: 40.0dB  
 8 12 16 20 24 28 32 36 40  
 NsMAR: 16.0dB QLY: PASS  
 3 7 11 15 19 23

<10-9  
bBER | <10-9  
aBER

Err:000

ONID: 1 VER: 26 MENU

health tv  
 ASTRA 1  
 VPID: 200 APID: 300 PMT: 100  
 ANNEX : DVB-C  
 SYM.RATE: 6.111  
 ENCRYPT: Clear

Main measures and image.

## RELATED FUNCTIONS



Press repeatedly to navigate into CATV measures screens: Measures, Constellation.



Press to enter in the spectrum.

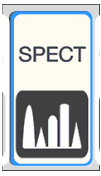

# SPECTRUM ANALYZER



Press the "HOME" key.



Touch "CATV" and then "SPECT" or use the encoder.

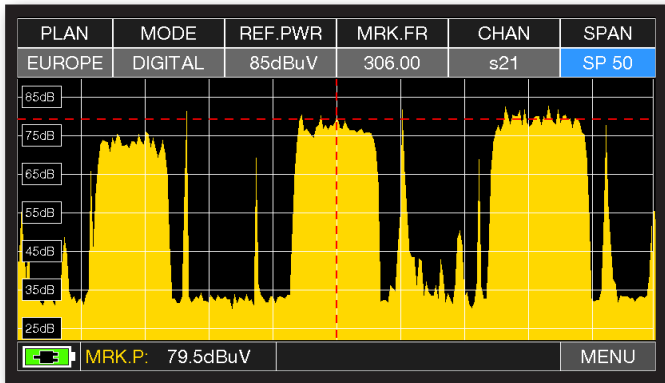

CATV spectrum SPAN 50 MHz.

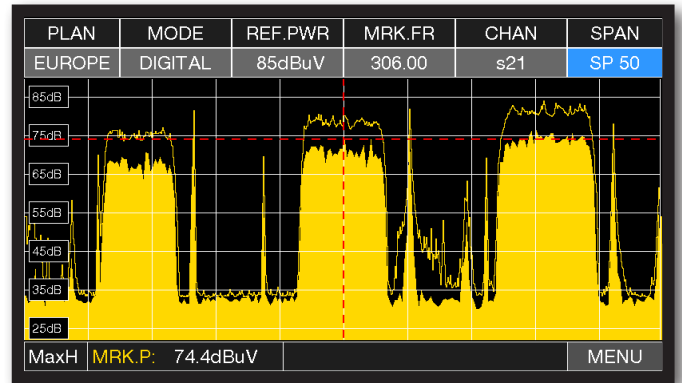

Press again to spectrum key to activate the "MAX HOLD" function.

Touch "SPAN" and rotate the encoder to select the desired SPAN value:  
1-2-5-7-10-20-50-100-200-500-FULL-UHF VHF

### Example 1:

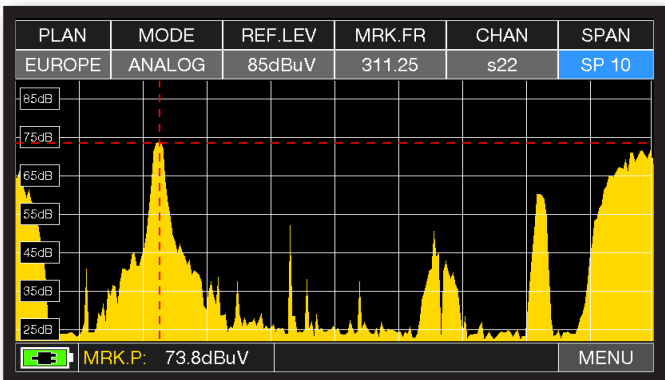

CATV spectrum SPAN "10 MHz".

### Example 2:

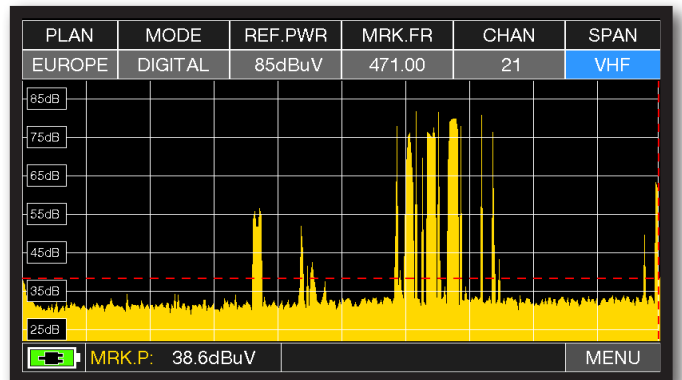

CATV spectrum SPAN VHF.

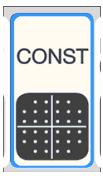

# CONSTELLATION ANALYSIS



Press the "HOME" key.



Touch "CATV" and then "CONST" or use the encoder.

## Example 1:

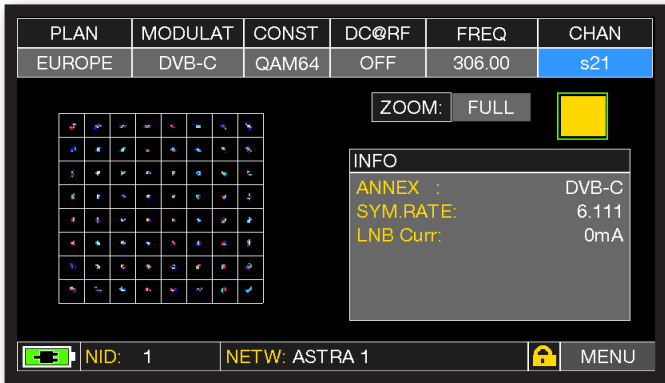

64 QAM constellation.

## Example 2:

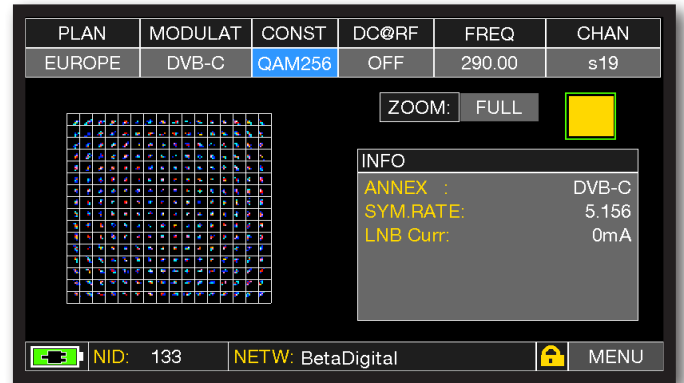

256 QAM constellation.



Touch "FULL" and select the box of constellation to enlarge.

## RELATED FUNCTIONS



Press repeatedly to navigate into CATV measures screens: Measures, Constellation.



Press to enter in the spectrum.



# LEAKAGE



Press the "HOME" key.



Touch "CATV" and then "LEAKAGE" or use the encoder.

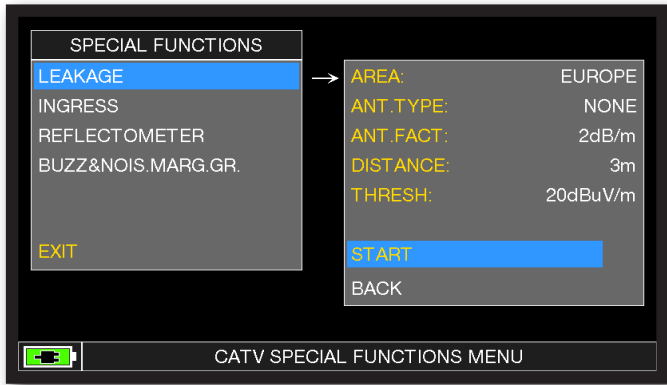

Set the desired parameters, at the end touch "START" to start the leakage measures.

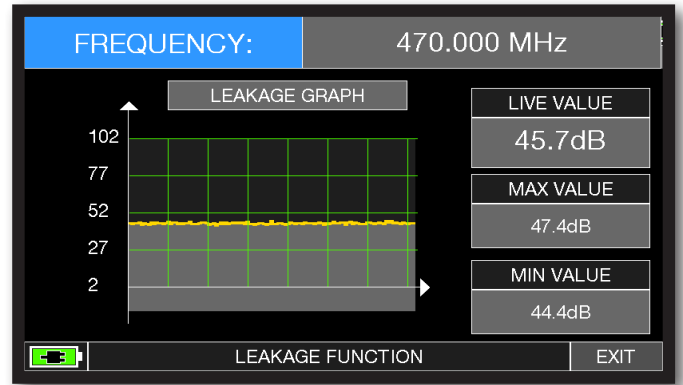

Leakage measures.



# INGRESS



Press the "HOME" key.



Touch "CATV" and then "LEAKAGE" or use the encoder.

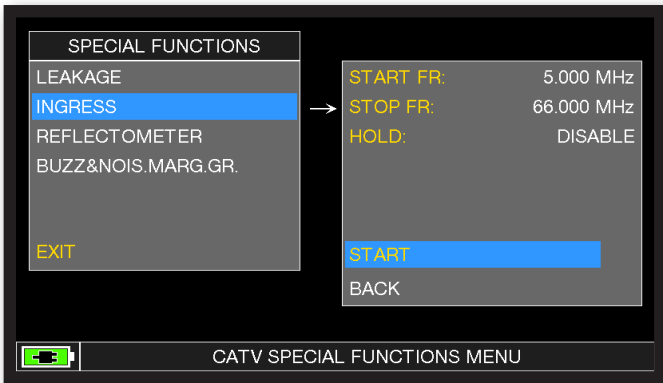

Set the desired parameters, at the end touch "START" to start the Ingress measures.

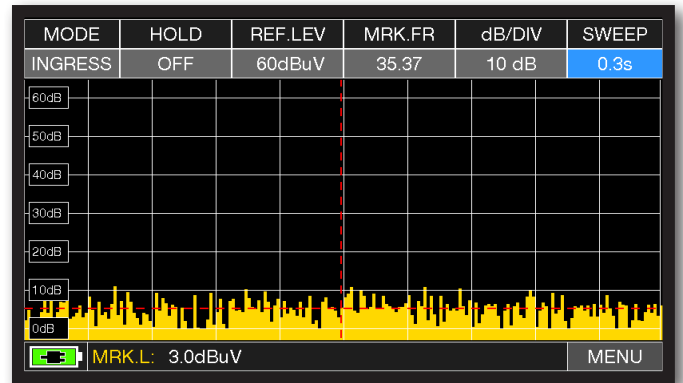

Ingress measures.



# IMAGES VISUALIZATION & SERVICE CHOICE



Press the "HOME" key.



Touch "CATV" and then "MPEG" or use the encoder.



Touch directly the RADIO/TV desired service or use the encoder

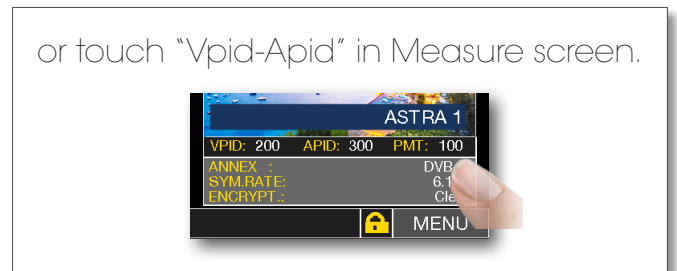

or touch "Vpid-Apid" in Measure screen.

PLAN	MODULAT	CONST	DC@RF	FREQ	CHAN
EUROPE	DVB-C	QAM64	OFF	306.00	s21
POWER: 78.7dBuV					
30	45	60	75	90	105 120
MER: 40.0dB					
8	12	16	20	24	28 32 36 40
NsMAR: 16.0dB QLY.PASS					
-1	3	7	11	15	19 23
<10-9 bBER			<10-9 aBER		
Err: 000					
ONID: 1		VER: 26		MENU	

Images and MPEG service list.



Touch the image to enlarge. Touch again to come back at the service list.

PLAN	MODULAT	CONST	DC@RF	FREQ	CHAN
EUROPE	DVB-C	QAM64	OFF	306.00	s21
NAME TYPE ENC					
health tv	TV	Y			
K-TV	TV	Y			
Deutsches Mu	TV	Y			
Lustkanal24	TV	Y			
MEDIA BROADC	TV	Y			
GayBoys LIVE	TV	Y			
RAPS	DATA	N			
DATE: 02/08/2017					
VIDEO RATE: 2.97 Mb/s					
NID: 1		NETW: ASTRA 1		MENU	

RADIO & TV service selection.

## RELATED FUNCTIONS



Press repeatedly to navigate into CATV measures screens: Measures, Constellation.



Press to enter in the spectrum.



# CHANNEL MONITOR

The weekly application of SW CHANNEL MONITOR allow you to control and register the trend of the main parameters of a digital signal over time (from 30 minutes to one week): TV, CATV & SAT. This application is indicated to resolve the reception problems which occur occasionally, it allow you also to measure, memorize and visualize (local or in remote) the digital signals parameters tested: DVB-S/T/C = Power, MER, ERROR, bBer, aBer; DVB-S2 / T2 / C2 = Power, MER, ERROR, aBer, Lber, PER, LDCCP.

Every registered parameters is graphically represented on the display using differents colours for a easy identification.



Press the "HOME" key.



Touch "CATV" and then "CH MONITOR" or use the encoder.

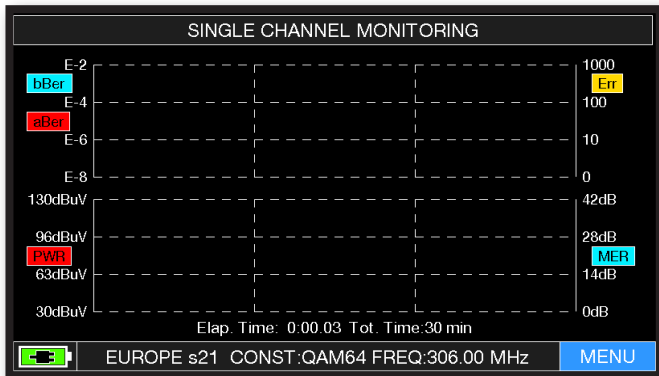

Touch "MENU"

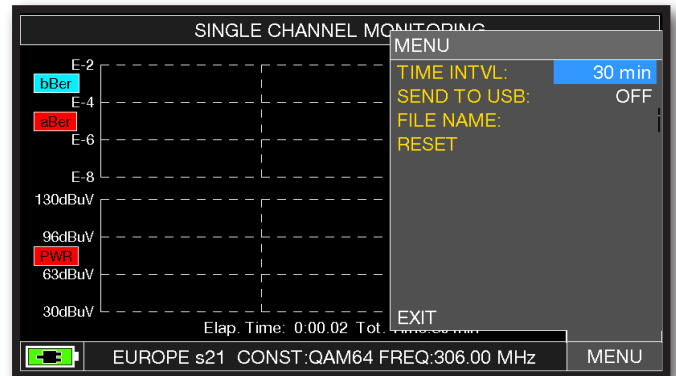

Select the time interval (TIME INTVL) and where you want to store the file, either in the meter's memory, or in the USB memory stick (send to USB-ON), with the relative file name (File name).

## Example 1:

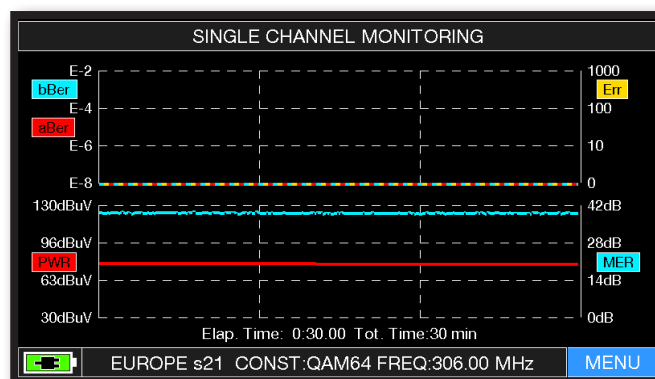

SINGLE CHANNEL MONITORING: 30 minutes.

**NOTE:** the Channel Monitor function is available also in TV and SAT mode.





# SPECTRUM ANALYSIS

After selecting the desired Operation Mode, TV, CATV or SAT, you can directly access the Spectrum Analyzer by touching the "SPECT" icon from the "HOME" menu or by pressing the "SPECT" button directly.

## SAT SPECTRUM



Press the "HOME" key.

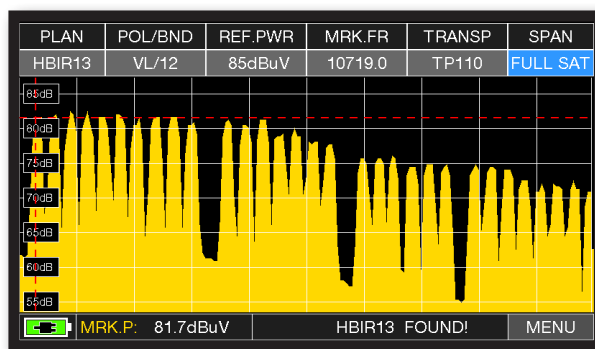

SAT spectrum.

## TV SPECTRUM



Press the "HOME" key.

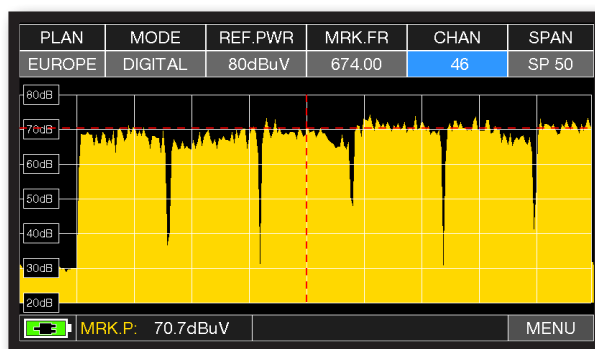

TV spectrum.

## CATV SPECTRUM

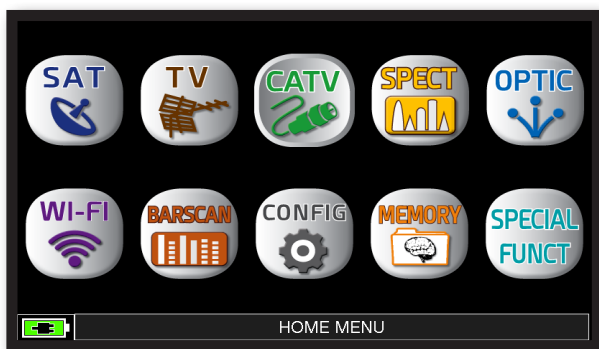

Press the "HOME" key.

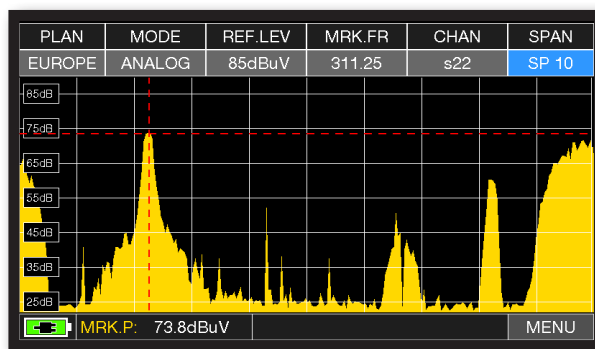

CATV spectrum.



# OPTICAL MEASUREMENTS (opt.)

The instrument, equipped with an internal optical converter, allows you to perform POWER and OPTICAL ATTENUATION measurements as well as perform RF measurements from optical inputs, decode services, and display Spectrum.

## OPTICAL POWER & ATTENUATION MEASURES



Press the "HOME" key.



Touch "OPTIC" and then "PWR METER" or use the encoder.

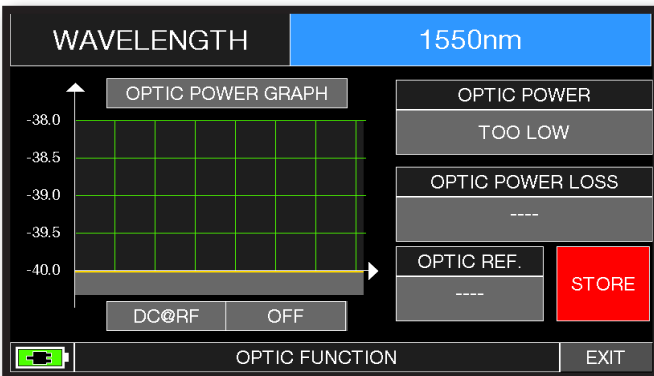

Touch "WAVELENGTH" and select the Wave length desired: for Example 1550 nm.

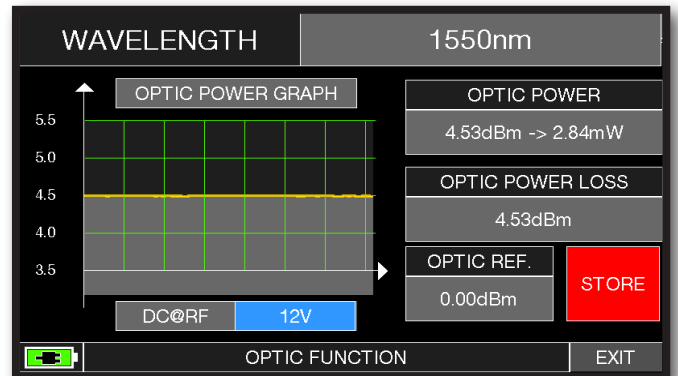

Touch "DC@RF" and, if required, select the power supply voltage: for Example 12V.

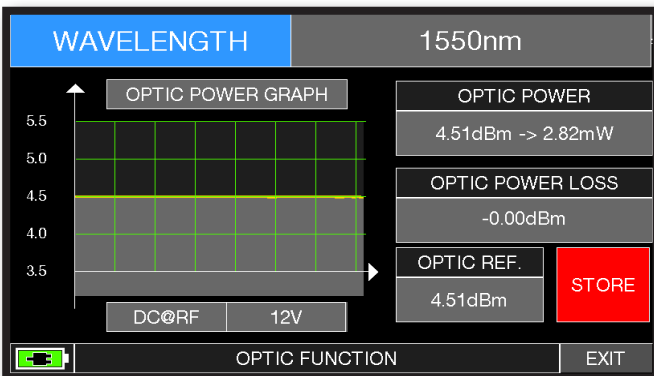

Touch "STORE" and memorizes the measured optical power value (Optic Ref.): for Example 4,51 dBm.

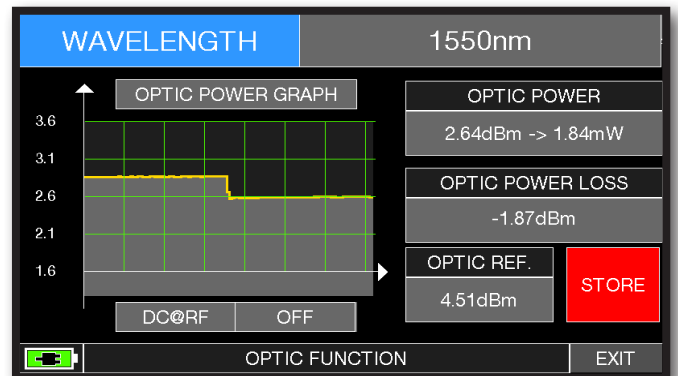

In the "OPTIC POWER LOSS" field, the optical attenuation value is displayed with respect to the stored value (Optic REF): for Example - 1.87 dBm.

# OPTICAL INPUT RF MEASURES



Press the "HOME" key.



Touch "OPTIC" and then "MEAS & PICT" or use the encoder.

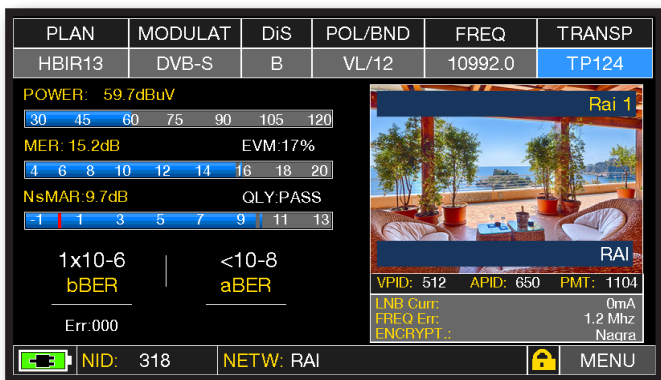

Main measures and image.

**NOTE:** In optical mode, you can measure the spectrum and measure just on Low Band Vertical Transponders (VL).

## RF SPECTRUM FORM OPTIC INGRESS



Press the "HOME" key.



Touch "OPTIC" and then "SPECT" or use the encoder.

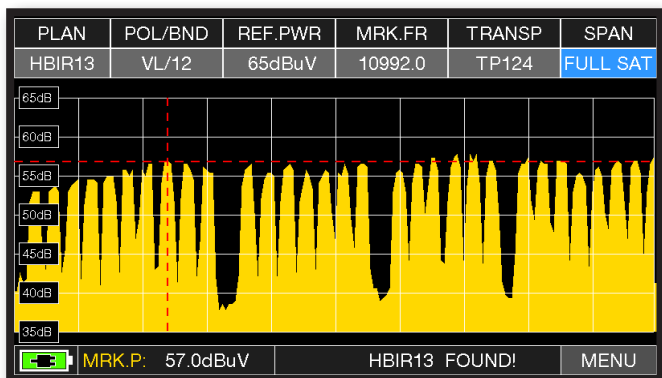

SAT spectrum SPAN "Full SAT" (from 930 to 2250 MHz).

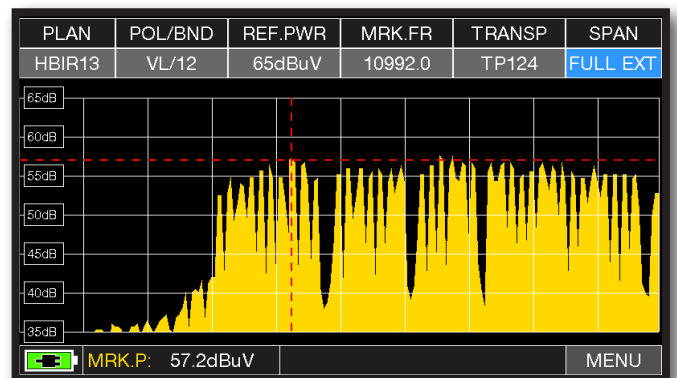

SAT spectrum SPAN "Full EXT" (from 230 to 2610 MHz).

**NOTE:** In OPTIC mode it is possible to analyze the spectrum and measure only vertical/low band (VL) transponders.

## FIBER OPTIC AND REMOTE POWER SUPPLY CABLE CONNECTION

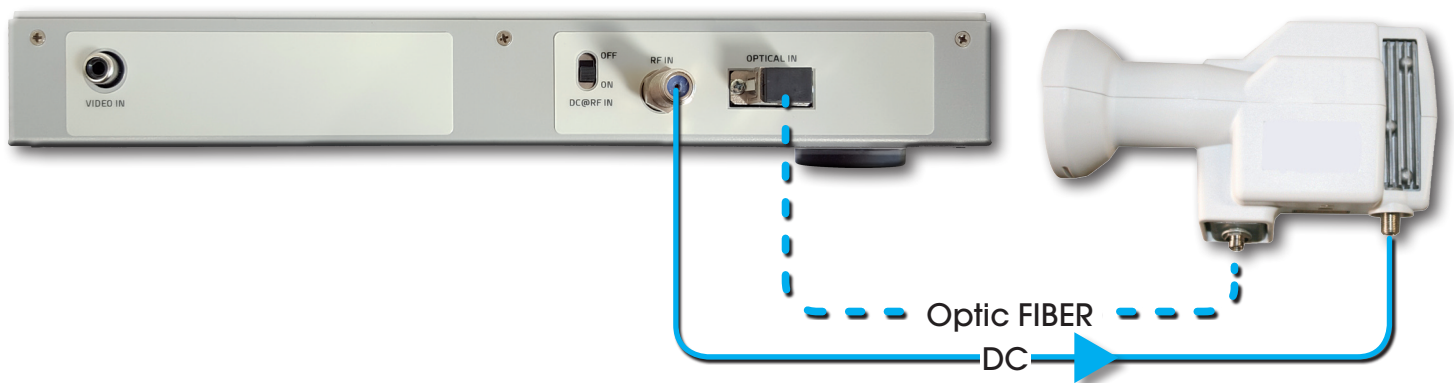

**NOTE:** for more information about the "APP"s, contact your distributor or send an e-mail to: [wecare@roverinstruments.com](mailto:wecare@roverinstruments.com)



# WI-FI ANALYZER (opt.)

The instrument, equipped with an WI-FI analyzer, allows you to analyze the WI-FI networks present in the building in the 2.4 and 5 GHz frequency range, check the power of the received Signal and display the List of Networks.



Press the "HOME" key.

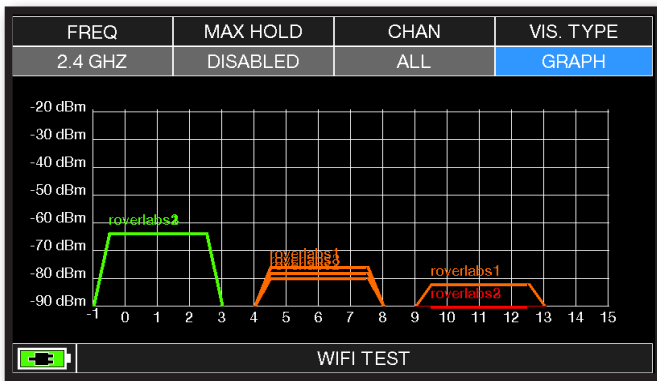

Touch "WI-FI" to visualize the received WI-FI networks.

WIFI Channel List 2.4 GHz				
ssid	signal	ch	security	MACADDRESS
roverlabs1	-58	1	wpa2	0014c2b6d5c0
roverlabs3	-58	1	wpa2	0014c2b6d5c1
roverlabs2	-58	1	wpa2	0014c2b6d5c2
roverlabs1	-76	6	wpa2	0014c2b63b30
roverlabs3	-76	6	wpa2	0014c2b63b31
roverlabs2	-76	6	wpa2	0014c2b63b32

Touch "VIS. TYPE" to access to the received WI-FI network list.

- Touch "FREQ" to switch WI-FI band from 2,4 to 5 GHz.
- Touch "MAX HOLD" to enable/disable the maximum level of the received signal memorized.
- Touch "CHAN" to select channels reception modalities, all or from 1 to 13 (for 2,4 GHz networks) and from 36 to 165 (for 5 GHz networks).



# BARSCAN CHECK ALL CHANNELS LEVEL/POWER



Or



Press the "HOME" key, then touch "BARSCAN".

In the TV standard canalization the meter displays the level/power of all TV channels. In AUTOMEMORY or MANUMEMORY PLAN the meter displays the memorized channels and distinguishes Analog and Digital signals using 2 different colours.

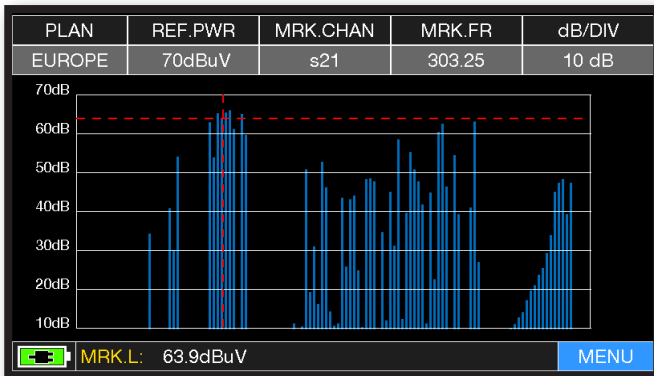

Standard BARSCAN TV canalization.

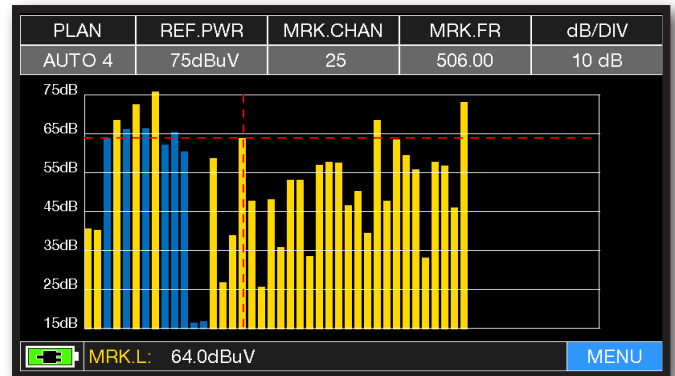

BARSCAN AUTO/MANUALMEMORY.

MENU

Touch "MENU" to choose the bargraph mode: "LEVEL" or "TILT".

ANALOG CHANNELS      DIGITAL CHANNELS

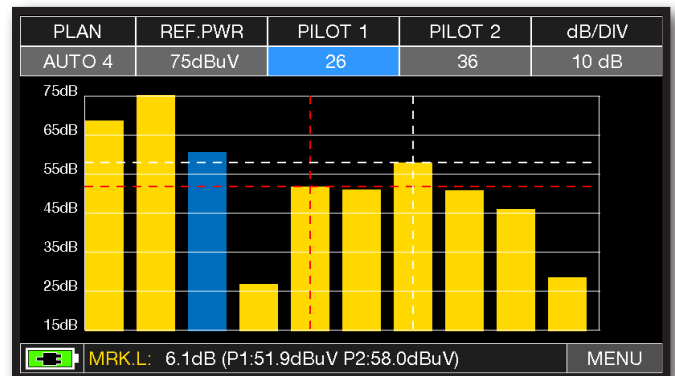

BARSCAN (TILT GRAPHIC). Touch "PILOT 1" and "PILOT 2" to select the two channels to be used for the tilt measurement (level difference).

**NOTE:** Function available only in TV or CATV mode.



# MEMORY: CHANNEL PLANS AND LOG FILES



## AUTOMEMORY (TV)



Press the "HOME" key.



Touch "AUTOMEMORY tv" or use the encoder.

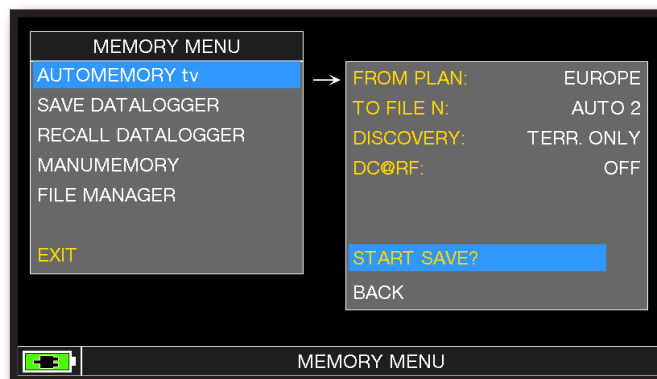

Set the desired parameters:

- Touch "to FILE N" and select the destination file "AUTO" where the search must be saved.  
Touch "DISCOVERY" and set the channel search mode:
- TERR ONLY (terrestrial only)
  - TERR & CABLE (terrestrial & cable)
  - Touch "DC&RF" and set the required power supply voltage.
- Touch "START SAVE" to create a new channel plan and to activate the search.

**NOTE:** If the words "START OVERWRITE" appear, the selected file will be overwritten. wait a few mins, the meter indicates the recorded ANALOG & DIGITAL Channels.

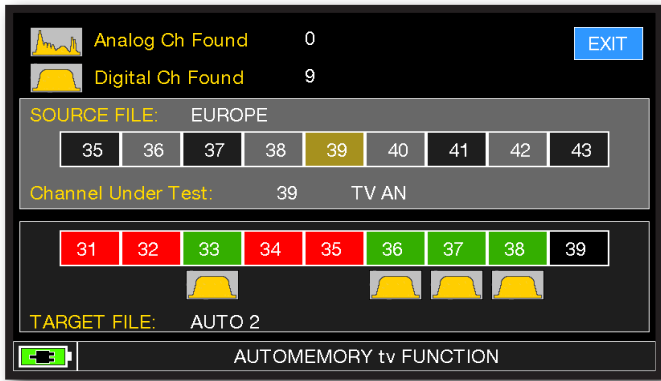

Search channels in progress.

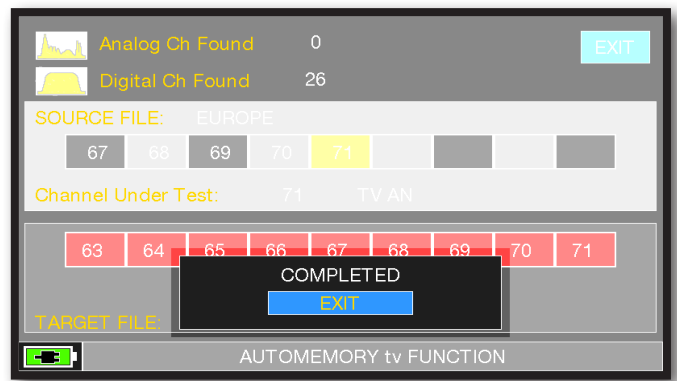

Search channels complete.

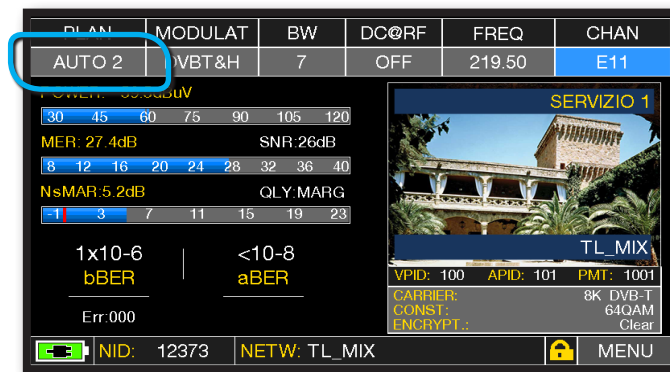

Once the Automemory is completed, the "AUTO" plan is automatically selected.



# LOGGER SAVE (TV/CATV)



Press the "HOME" key.



Touch "SPECIAL FUNCT" and then "SAVE DATALOGGER".

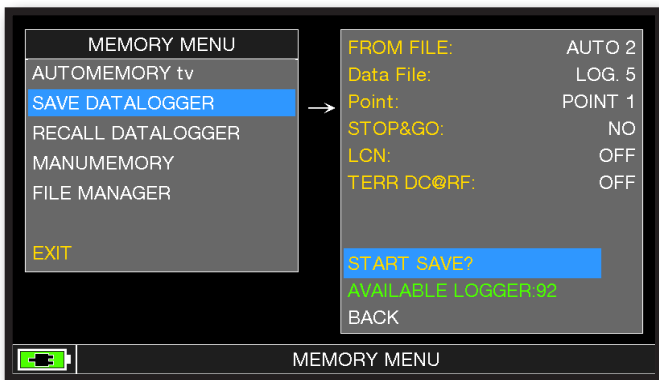

Touch "SAVE DATALOGGER" and set the parameters required. Touch "START SAVE" to create a new log file.

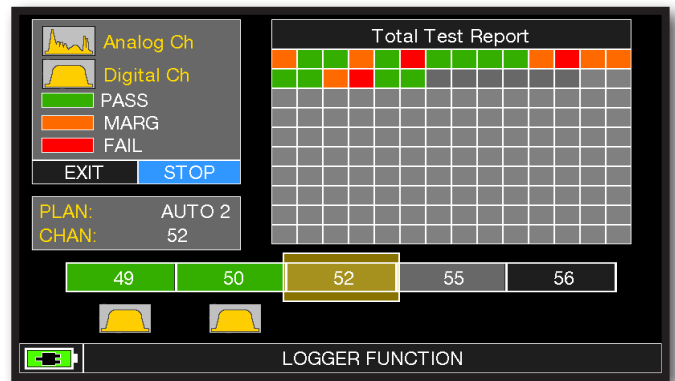

DATA LOGGER run.

**NOTE:** if the MANU plan has mixed TV and SAT programs, the "STOP&GO" function will assist when running a LOGGER asking to move the cable lead from a TV to a SAT signal source.

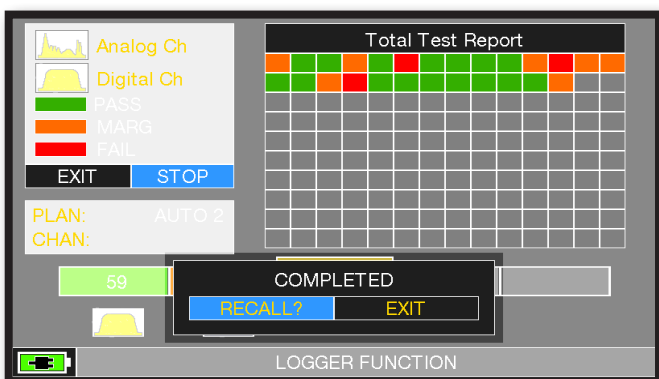

Touch "RECALL" to recall the Logger or "EXIT" to exit.

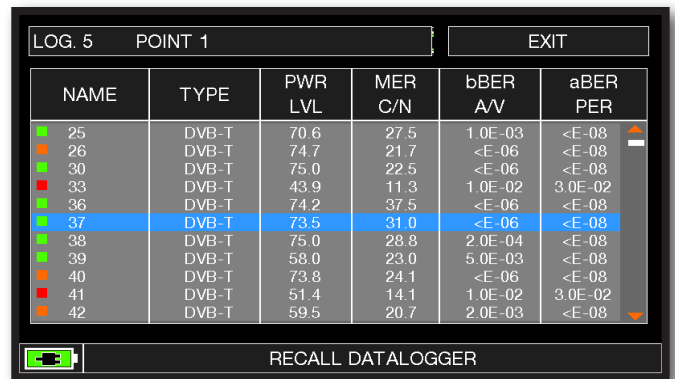

Example of saved measured in the Log file. Touch the screen to browse through measurements saved in the log file.

# LOGGER RECALL (TV/CATV)



Press the "HOME" key.

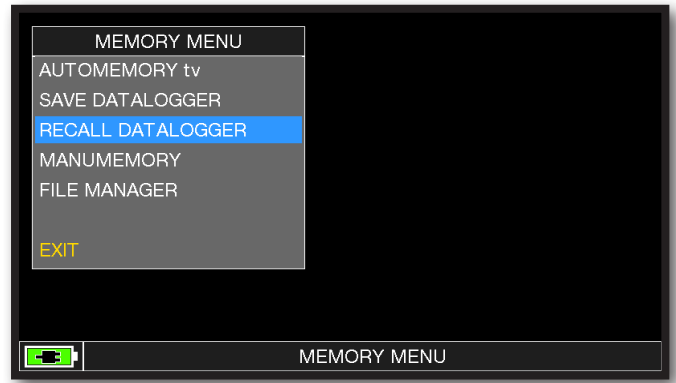

Touch "SPECIAL FUNCT" and then "RECALL DATALOGGER".

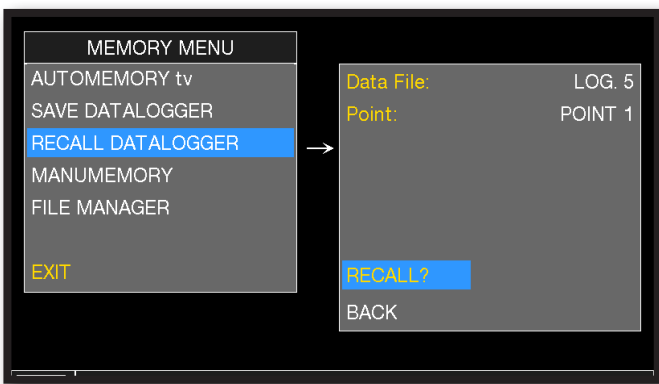

Touch "RECALL DATALOGGER" and Set the LOG file parameters. Touch "RECALL?" to see them.

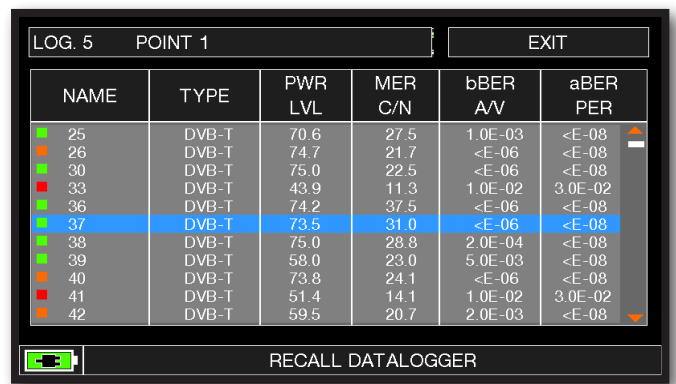

Example of saved measured in the Log file. Touch the screen to browse through measurements.

# LOGGER SAVE (SAT)



Press the "HOME" key.

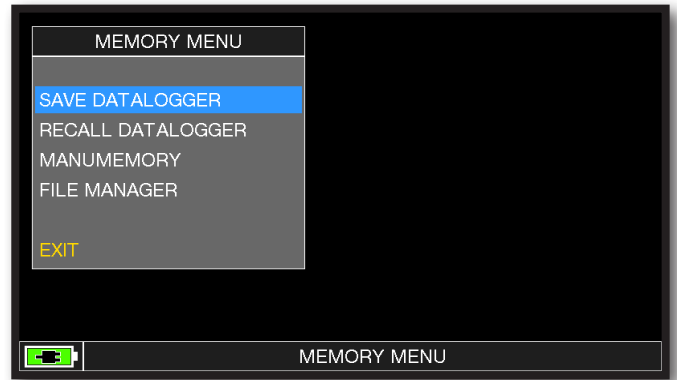

Touch "SPECIAL FUNCT" and then "SAVE DATALOGGER"

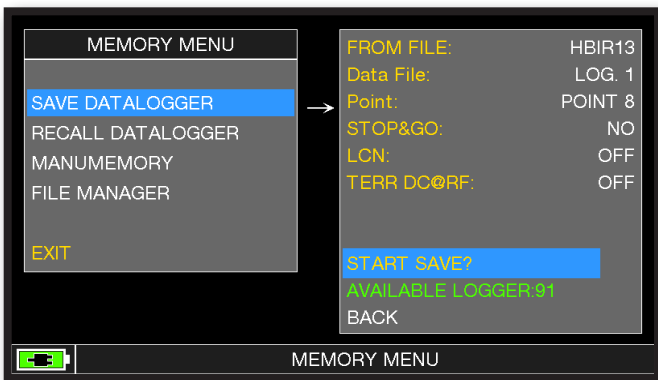

Touch "SAVE DATALOGGER" and set the parameters required. Touch "START SAVE" to create a new log file.

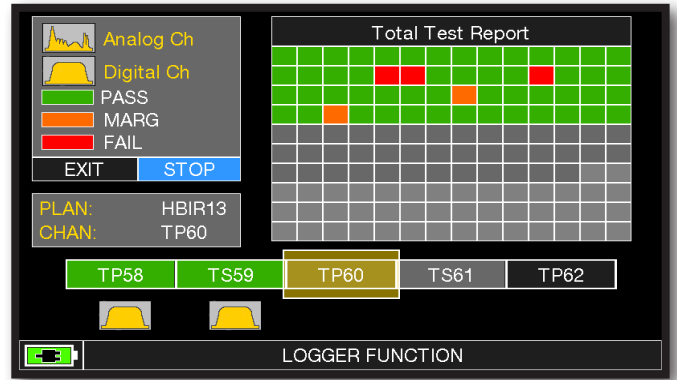

DATA LOGGER run.

**NOTE:** if the MANU plan has mixed TV and SAT programs, the "STOP&GO" function will assist when running a LOGGER asking to move the cable lead from a TV to a SAT signal source.

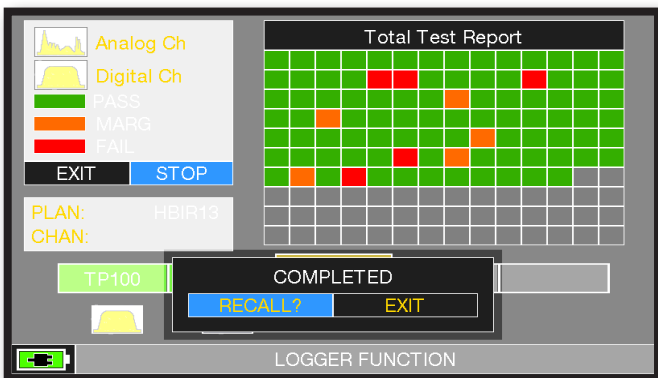

Touch "RECALL" to recall the Logger or "EXIT" to exit.

LOG. 1 POINT 8		EXIT			
NAME	TYPE	PWR LVL	MER C/N	bBER A/V	aBER PER
TP110	DVB-S2	68.1	14.5	4.0E-03	<E-07
TS111	DVB-S2	71.2	15.4	3.0E-03	<E-07
TS112	DVB-S2	68.6	14.8	2.0E-03	<E-07
TS114	DVB-S2	65.5	14.5	4.0E-03	<E-07
TP115	DVB-S	69.4	14.4	4.0E-06	<E-08
TS116	DVB-S2	65.6	13.5	5.0E-03	<E-07
TS117	DVB-S2	69.5	14.5	5.0E-03	<E-07
TP118	DVB-S	63.2	13.3	1.0E-05	<E-08
TP119	DVB-S2	67.0	16.6	6.0E-04	<E-07
TS120	DVB-S2	62.1	13.7	6.0E-03	<E-07
TS121	DVB-S2	65.0	14.2	6.0E-03	<E-07

Example of saved measured in the Log file. Touch the screen to browse through measurements.

# LOGGER RECALL (SAT)



Press the "HOME" key.

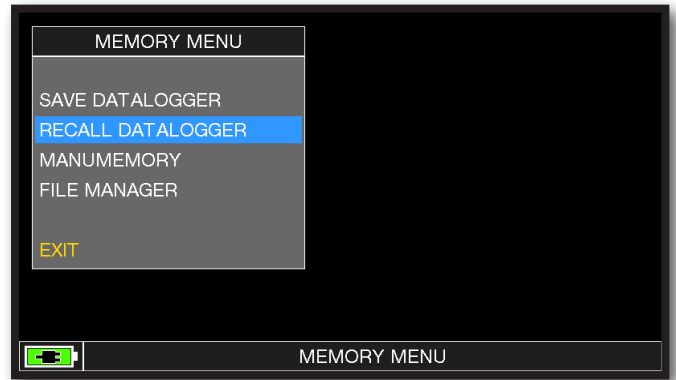

Touch "SPECIAL FUNCT" and then "RECALL DATALOGGER".

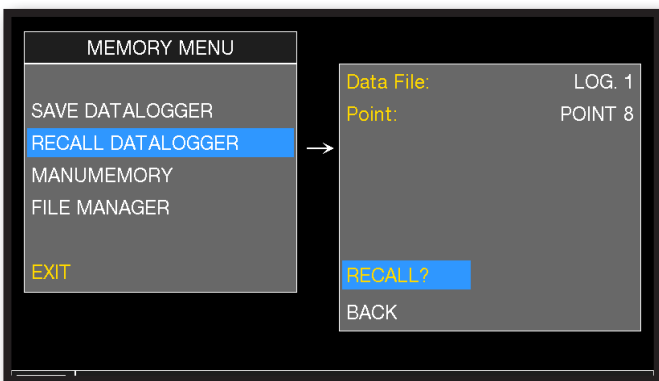

Touch "RECALL DATALOGGER" and Set the LOG file parameters. Touch "RECALL?" to see them.

LOG. 1		POINT 8		EXIT		
NAME	TYPE	PWR LVL	MER C/N	bBER A/V	aBER PER	
TP110	DVB-S2	68.1	14.5	4.0E-03	<E-07	▲
TS111	DVB-S2	71.2	15.4	3.0E-03	<E-07	
TS112	DVB-S2	68.6	14.8	2.0E-03	<E-07	
TS114	DVB-S2	65.5	14.5	4.0E-03	<E-07	
TP115	DVB-S	69.4	14.4	4.0E-06	<E-08	
TS116	DVB-S2	65.6	13.5	5.0E-03	<E-07	
TS117	DVB-S2	69.5	14.5	5.0E-03	<E-07	
TP118	DVB-S	63.2	13.3	1.0E-05	<E-08	
TP119	DVB-S2	67.0	16.6	6.0E-04	<E-07	
TS120	DVB-S2	62.1	13.7	6.0E-03	<E-07	
TS121	DVB-S2	65.0	14.2	6.0E-03	<E-07	▼

Example of saved measured in the Log file. Touch the screen to browse through measurements.



**NOTE:** the special functions depend on the active operating mode: TV SAT or CATV

## RIFLECTOMETER

The instrument, equipped with "SW RIFLECTOMETER App", allows you to check the correct impedance matching of a 75Ω distribution installation.

Through the use of calibrated noise generator (for Example ROVER mod. CNG 90 STC/CNG 70 USB), if in a distribution installation there was an impedance mismatch, such as a cable short-circuit, a cable cut or a not properly terminated cable to a 75 ohm dummy load, it will create a standing wave pattern that can be seen on the spectrum of the instrument as shown in the figures below.



In TV mode press the "HOME" key.

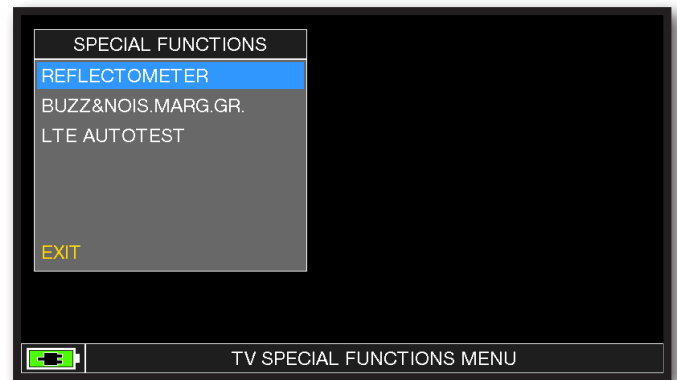

Touch "SPECIAL FUNCT" and then "REFLECTOMETER".

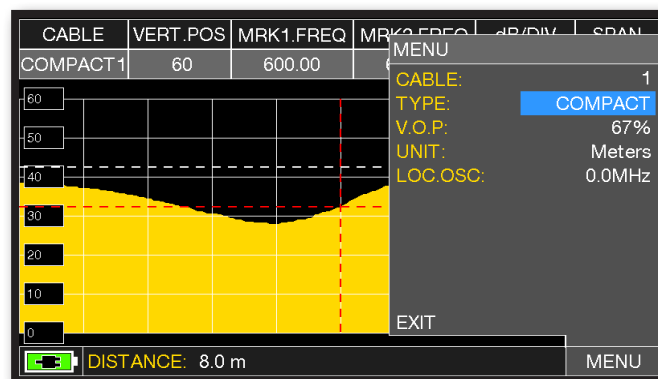

Touch "MENU" and set the features of the coaxial cable you need to analyze (see next page), at the end touch "EXIT".

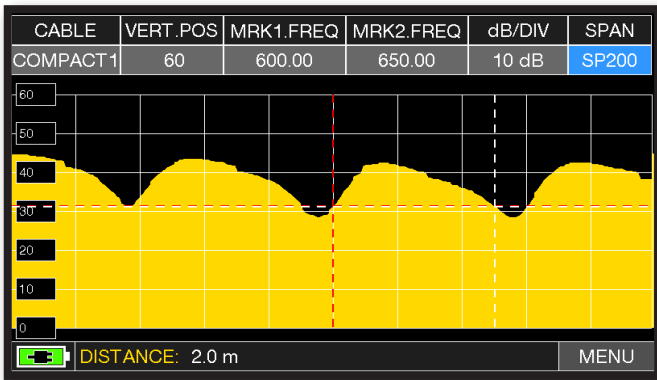

Touch "SPAN" and select the correct visualization value.

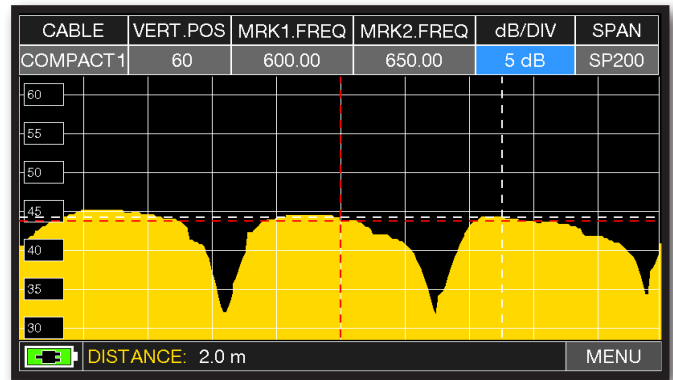

Touch "dB DIV" and select the correct visualization value.

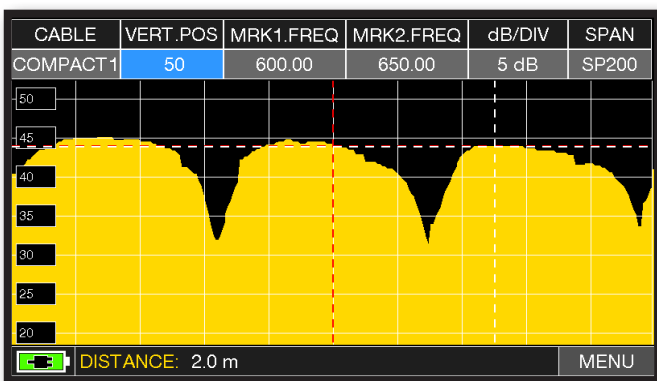

Touch "VERT.POS" and select the correct visualization value.

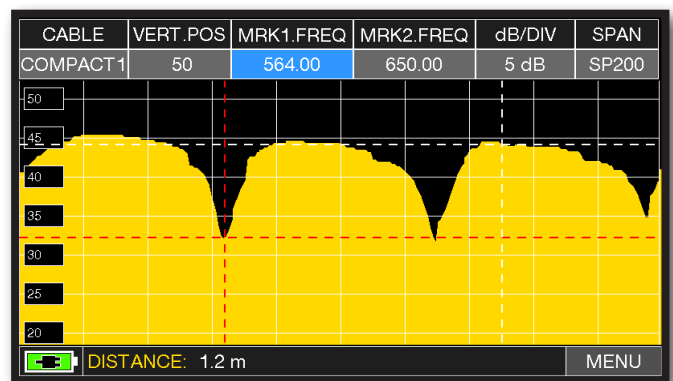

Touch "MRK1.freq" then "MRK2.freq" and set the marker frequencies in correspondence with the first and second minimum points.

### Example 1:

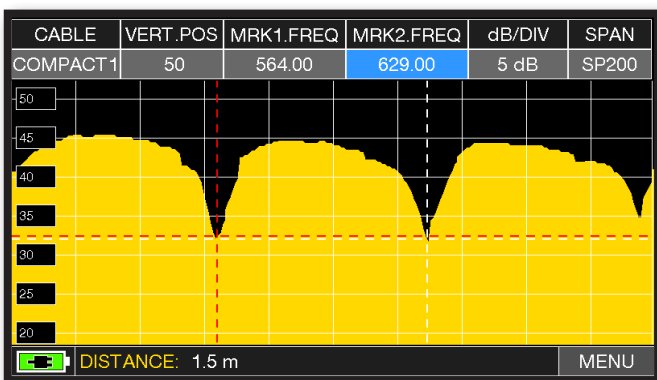

In the DISTANCE window, read the cable's mismatching value: example 1.5 m.

### Example 2:

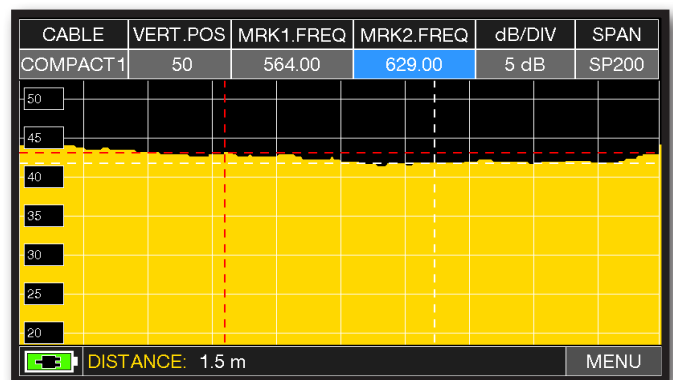

In the DISTANCE window, read the cable's mismatching value: example 1.5 m.

# CONFIGURATION OF COAXIAL CABLES

Cable: from 1 to 5.

- Default coaxial cable configurations (adjustable).

TYPE: Type of cable to be tested.

- AIRSPACE: coaxial cable with dielectric in the air.
- COMPACT: coaxial cable with compact dielectric.
- FOAM: coaxial cable with foam dielectric.

V.O.P.: Propagation speed.

- Set the value provided by the cable manufacturer.

UNIT: Measurement unit.

- Set the value in meters or feet.

PICTURE: Spectrum graphics.

- Set the spectrum graphics mode to FULL or CONTOURS.

LOC.OSC.: LOCAL TV OSCILLATOR.

- Leave the value set by the manufacturer: 0 MHz.

## CONNECTION DIAGRAM



**NOTE:** for more information about the "APP"s, contact your distributor or send an e-mail to: [wecare@roverinstruments.com](mailto:wecare@roverinstruments.com)

# BUZZER & NOISE MARGIN GRAPH



Press the "HOME" key.

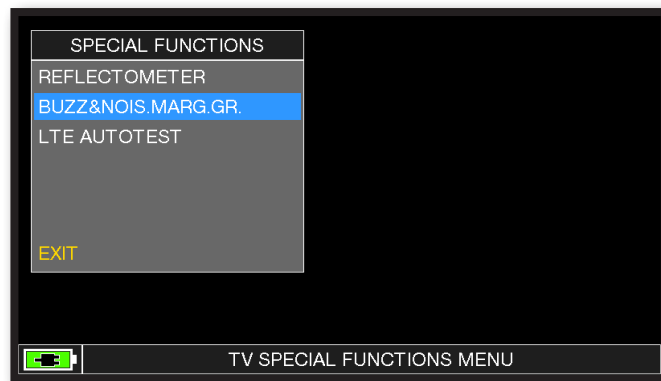

Touch "SPECIAL FUNCT",  
and then touch "BUZZ & NOIS MARGIN".

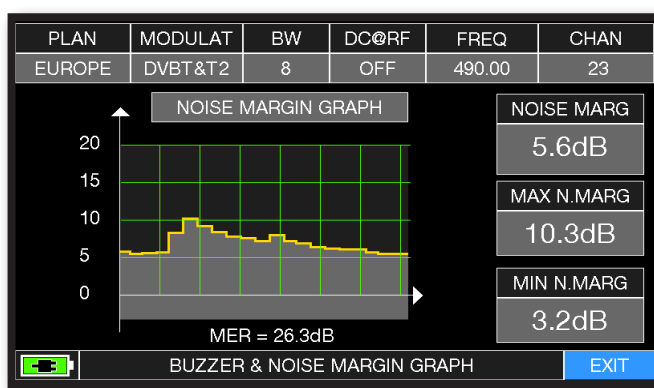

Buzzer & Graphic of the progress of the noise  
NOISE MARGIN of the tuned channel according to time.

- high tones = the BEST Noise Margin level
- deep tones = the WORST noise margin level
- Noise Marg = real time noise margin
- Max n.marg = maximum stored noise margin
- MER = MER in real time.

**NOTE:** The function is also available in CATV and SAT mode.



# TEST INTERFERENZE LTE



Or touch 2 time  
"BARSCAN" key.

In TV or CATV mode  
press the "HOME" key.

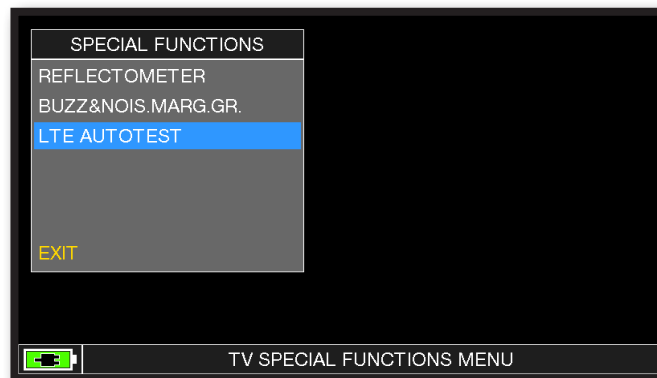

Touch "SPECIAL FUNCT",  
and then "LTE AUTOTEST".

Example 1:

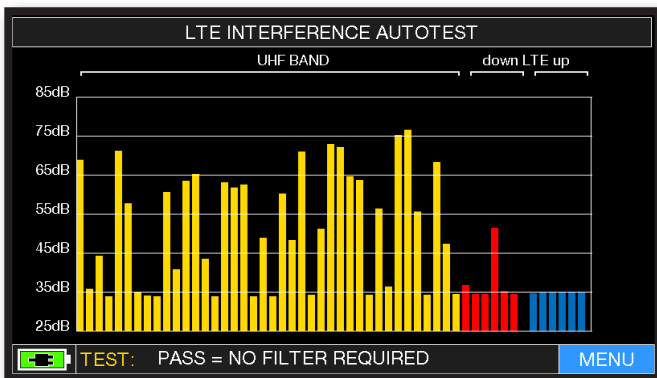

low LTE interference.  
The lower part of the display shows  
the following information:  
PASS = NO filter required  
(No interference detected).

Example 2:

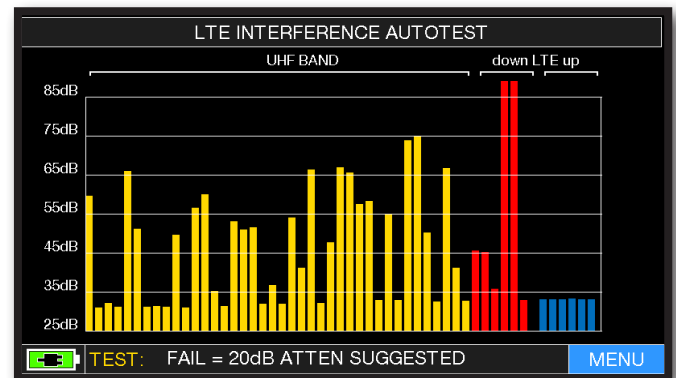

High LTE interference.  
The lower part of the display shows the  
following information:  
FAIL = 20dB ATTEN SUGGESTED  
(the instrument suggests attenuating the  
interfering LTE signals by 20 dB)



**NOTE:** the special functions depend on the active operating mode: TV SAT or CATV.

## BUZZER & NOISE MARGIN GRAPH



Press the "HOME" key.

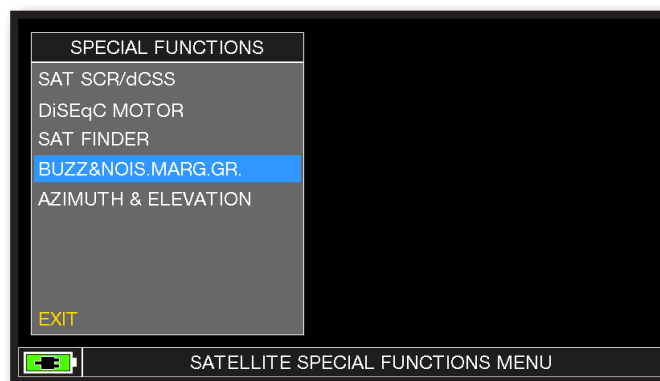

Touch "SPECIAL FUNCT", and then touch "BUZZ & NOIS MARGIN".

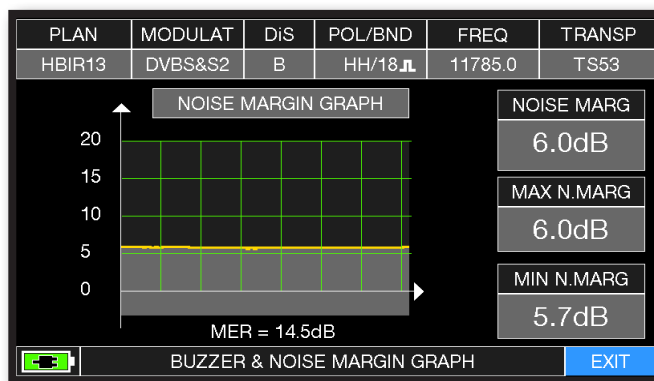

Buzzer & Graphic of the progress of the noise NOISE MARGIN of the tuned channel according to time.

- high tones = the BEST Noise Margin level
- deep tones = the WORST noise margin level
- Noise Marg = real time noise margin
- Max n.marg = maximum stored noise margin
- MER = MER in real time.

**NOTE:** The function is also available in CATV and TV mode.

# OPTIONAL “APPS”

## REMOTE CONTROL

The SW REMOTE CONTROL application allow to configure and memorized the instruments and all measurements remotely via web browser (PC, TABLET and SMARTPHONE)

### “DHCP” CONFIGURATION EXAMPLES.

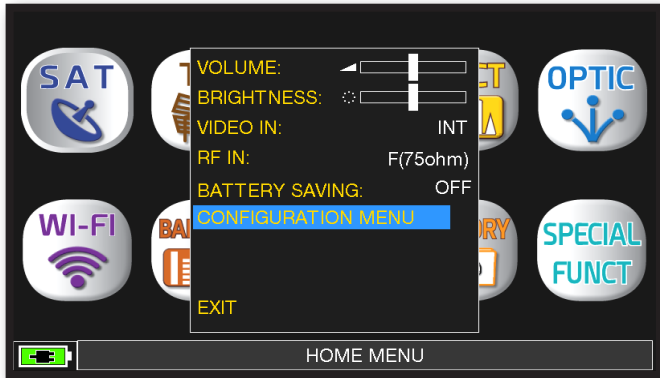

Touch “CONFIGURATION MENU” from “VOLUME” screen.

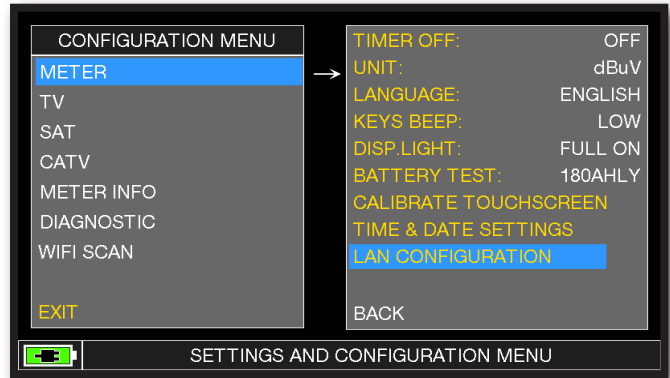

Touch “METER” and then “LAN CONFIGURATION”.



Touch “IP CONFIG” and select “DHCP”.



Touch “CHECK”.



IP address assignment to be inserted into the web browser done.



At the end touch “EXIT” to exit.

Example of "DHCP" remote connection:

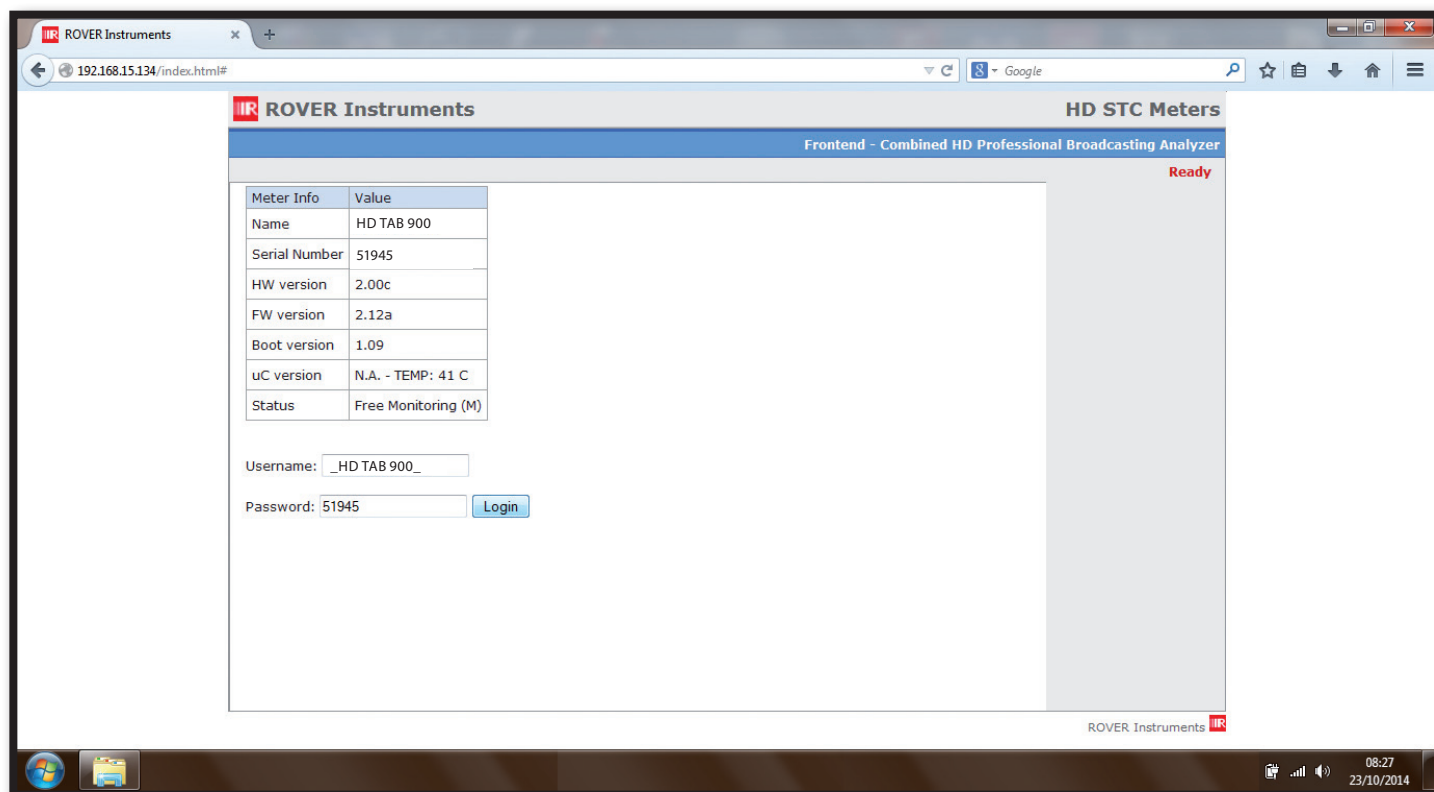

1. Open a web browser,
2. Insert the assigned IP, Example 192.168.15.134/index.html,
3. Insert in the "USERNAME" field the name of the instruments (NAME) preceded and followed with symbol\_ , Example: \_HD TAB 900\_,
4. Insert in the "PASSWORD" field the Instrument Serial Number, Example: 51945,
5. Make the "LOGIN".

# EXAMPLE OF "STATIC" CONFIGURATION.

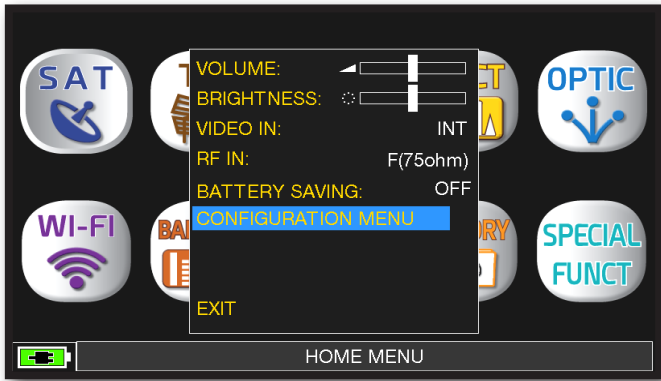

Touch "CONFIGURATION MENU" from "VOLUME" screen.

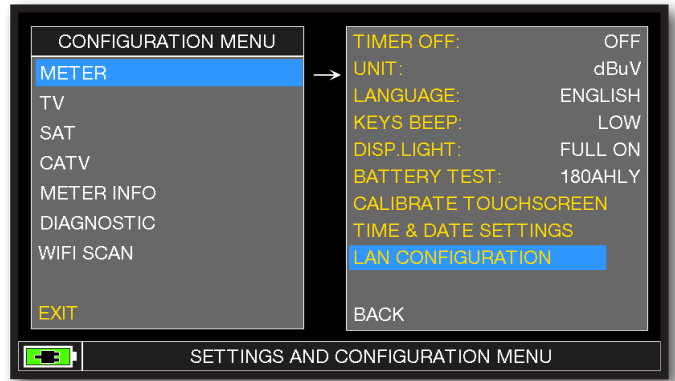

Touch "METER" and then "LAN CONFIGURATION"

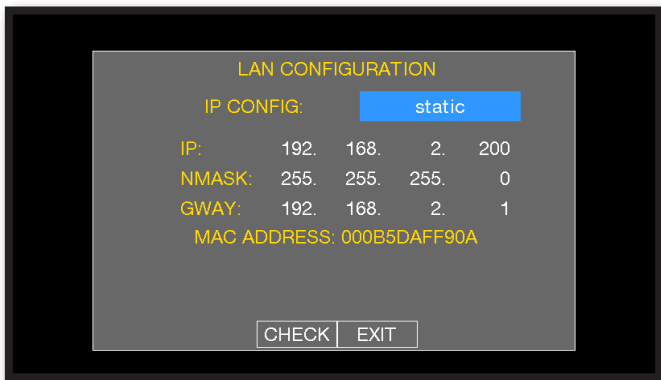

Touch "IP CONFIG" and select "STATIC", insert the "IP", "NMASK" and "GWAY" parameters.

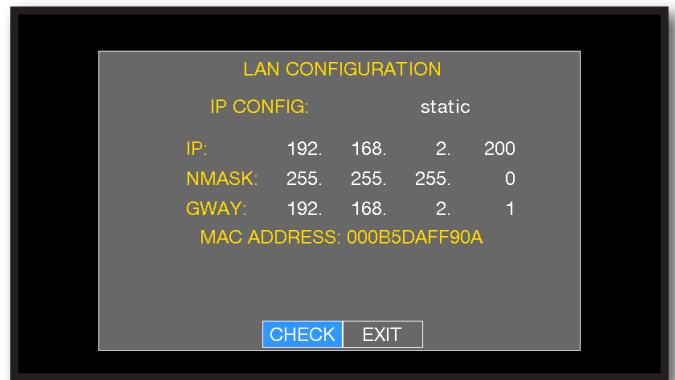

Touch "CHECK".



At the end touch "EXIT" to exit.

**NOTE:** for more information about the "APP"s, contact your distributor or send an e-mail to: [wecare@roverinstruments.com](mailto:wecare@roverinstruments.com)

# SERVICE AND SUPPORT WEB REGISTRATION AND SOFTWARE UPGRADES

## FREE SW UPGRADE and NEWSLETTER SERVICE:

- ROVER offers you the possibility of carrying out **Free Software and Memory Plan Upgrades** on your Meters, by simply REGISTERING your data in the **Update SW Area**;
- Once you have registered, you can download the **ROVER S.M.A.R.T. program free of charge**, which is necessary for the installation of SW and/or Memory Plan upgrades;
- ROVER also offers you the possibility of registering to our **Newsletter** service, which allows you to receive, by email and **free of charge**, information regarding: New SW upgrades, Technical Communications, Training Courses, Technical Articles, Product News, Invitations to exhibitions and roadshows and much more besides.

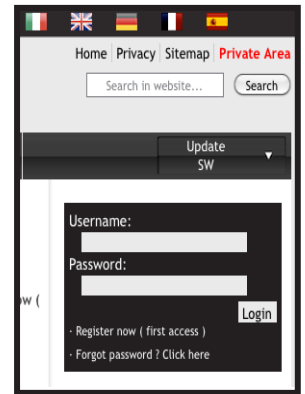

## UPDATE SW AREA REGISTRATION:

If you have not already registered, click on the words **“Update SW”** in the menu in the top, right-hand corner of your screen:

- Click on **“Register Now (First Access)”** in the dropdown menu to access the Update SW Area;
- Fill in the electronic form with all **your Personal Information** and the **Username** of your choice;
- After you have completed the form, confirm by pressing the black **“Send”** key at the bottom of the page;
- Once sent, a page will be shown with a summary of your **Registration Data**, where you can modify your data by clicking on the **BLUE “Change Data”** key, print it by clicking on the **BLACK “Print Data”** key or directly access the Update SW Area by clicking on the **RED “Access SW Upgrade Area”** key;
- You will also receive an **e-mail** message, reminding you of your chosen **User Name** and the **Password** assigned by ROVER. Keep it in a safe place for future access to the Update SW Area and so that you can download new SW upgrades and/or Memory Plans;
- If you **lose** your User Name or your Password assigned by ROVER, click on the function **“Forgot User Name or Password? Click here”** in the drop down menu in the **“Update SW”**.

## S.M.A.R.T. PROGRAM

The S.M.A.R.T. program was created by ROVER to enable you to interface your Meter with a PC. After you have accessed the Update SW Area, download and install the ROVER S.M.A.R.T. program on your PC for SW upgrades and upload Memory Plans (.mem).

The S.M.A.R.T. program allows you to continuously update your Meter's SW and to create mixed SAT-TV-CATV Memory Plans, download Data Loggers and manage your Meter's Memory.

# SOFTWARE UPGRADES

## SOFTWARE UPGRADES:

Once you have identified and downloaded the correct **ROVER S.M.A.R.T.** program on your **PC** ( for more information, read the respective S.M.A.R.T. page in this user guide ) install it on your **PC** in order to upgrade your Meter's **Software ( SW )**. Then proceed as follows:

- In the **Update SW Area** identify the exact **Name/Model** of your Meter and click on the corresponding picture;
- Then click on the corresponding **"SW Upgrade"** file and download it on your PC;
- If you want to see more detailed information about the SW upgrade contents, click on the blue **"i"** icon.

## WARNING:

- Before carrying out your Meter's SW upgrades, we suggest you **close all the applications that are active on your PC**: e-mail messages, internet, management programs, etc.
- Also check that the Meter's batteries are charged and that the Meter is connected to the mains. Most importantly do not turn off or disconnect the Meter from the mains during the upgrade. The Meter will automatically turn off once the SW upgrade has been completed.

**N.B.** If the graphic of your PC bar shows that the upgrade advancement is blocked, do not interrupt the procedure because the SW download is still taking place even if the PC monitor does not correctly show the advancement in sequence.

## PROCEDURE:

1. Connect your Meter to the mains and turn it on;
2. Wait for the Start-Up phase of the Meter to finish correctly;
3. Connect the **USB** cable, **first** to the Meter and **then** to the **PC**;
4. Start up the **ROVER S.M.A.R.T.** program in your PC;
5. In the ROVER S.M.A.R.T. program window, click on **"Instrument"** followed by **"Upgrade Firmware"**;
6. In the **Open** window, select the **"SW Upgrade ( .rvr )"** downloaded from the Update SW Area;
7. Click on **"Open"** and confirm the selection;
- 8. The SW upgrade procedure will automatically start up;**
9. If this does not happen, the **Upgrade Firmware** window will open, select the exact model of your Meter and click on **"Upgrade"** to carry out the Upgrade manually;
10. Wait a few minutes, the ROVER S.M.A.R.T. program will load the new SW in your Meter;
11. Once the download has been completed, the following message on the PC will appear: **Power on the meter to activate FW \*\*PROGRAM SUCCESSFUL\*\***;
12. If the Meter did not automatically turn off, turn it back on again and check, in the Start-Up or Self-Test window ( METER INFO - INFO ABOUT ), the SW version number.

## WARNING:

In the case the update is interrupted or is not successful, check the USB cable connection and repeat the procedure from the beginning.

If the procedure described in this paragraph continues to fail, contact the ROVER After Sales and Service Department:

- e-mail: [wecare@roverinstruments.com](mailto:wecare@roverinstruments.com)
- Fax: +39 030 990 68 94

It is possible to download the Software Upgrade Procedure directly from the ROVER website at the following address: [www.roverinstruments.com](http://www.roverinstruments.com). Please refer to the "F.A.Q." section.

# TV & SAT MEMORY PLAN UPGRADES

## MEM PLANS UPGRADES:

Once you have identified and downloaded the correct ROVER S.M.A.R.T. PRO program on your PC ( for more information, read the respective S.M.A.R.T. page in this user guide ), install it on your PC in order to load the Memory Plans in your Meter. The proceed as follows:

- Once you have accessed the Update SW Area, identify the exact Model/Name of your Meter and click on the corresponding picture;
- Click on the relative file: "Plans and Satellites" and download it on your PC.

## WARNINGS:

- Before carrying out your Meter's Memory Plan upgrades, we suggest you close all the applications that are active on your computer: e-mail messages, internet, management programs, etc.
- Also check that the Meter's batteries are charged and that the Meter is connected to the mains. Most importantly do not turn off or disconnect the Meter from the mains during the upgrade.

**N.B.** If the graphic bar showing the upgrade advancement blocks, do not interrupt the procedure because the Memory Plan Upgrade is still taking place even if the PC monitor does not correctly show the advancement in sequence.

## PROCEDURE:

1. Connect your Meter to the mains and turn it on;
2. Wait for the Start Up phase of the Meter to finish correctly;
3. Connect the USB cable, first to the Meter and then to the PC;
4. Make sure that you have installed the PRO Version and start up the ROVER S.M.A.R.T. program in your PC;
5. In the ROVER S.M.A.R.T. PRO program window, click on "Instrument" followed by "Connect Instrument";
6. Click on "Tools", then "Mem" e and then "Open Mem" In the ROVER S.M.A.R.T. PRO program window;
7. In the Open window, select the "Memory Plan ( .mem )" downloaded from the Update SW Area;
8. Click on "Open" and confirm the selection;
9. Click on "Tools", then "Mem" and then "Write Mem to Instruments";
10. The following message will appear: WARNING: This operation will delete all the previous plans stored in the meter;
11. Click on "OK" and confirm to start the upgrade;
12. Wait a few minutes, the ROVER S.M.A.R.T. PRO program will load the new Memory Plans in your Meter;
13. Once the download has been completed, the following message will appear: Plan Memory download succesfully !.

## WARNING:

In the case the update is interrupted or is not successful, check the USB cable connection and repeat the procedure from the beginning.

If the procedure described in this paragraph continues to fail, contact the ROVER After Sales and Service Department:

- e-mail: [wecare@roverinstruments.com](mailto:wecare@roverinstruments.com)
- Fax: +39 030 990 68 94

It is possible to download the Software Upgrade Procedure directly from the ROVER website at the following address: [www.roverinstruments.com](http://www.roverinstruments.com). Please refer to the section "F.A.Q."



# LI-ION POLIMER BATTERIES

## IMPORTANT:

- DO NOT LEAVE THE BATTERIES DISCHARGED FOR LONG PERIODS;
- ALWAYS CHARGE THE BATTERIES AT NIGHT, EVEN IF THEY ARE NOT COMPLETELY DISCHARGED.

## USEFUL INFORMATION:

1. The batteries supplied are high quality and tested individually, the autonomy depending on the following conditions:
  - the LNB power consumption: Single, Dual or Quadruple;
  - the external temperature: with temperatures of less than 10°C, 20% of the capacity is lost;
  - the age of the batteries: a 10% loss in efficiency each year;
  - Remember that the TIMER OFF function, that automatically turns off the Meter after 5 or 10 minutes of inactivity saves up to 30%.
2. The battery indicator has a tolerance ( like all battery powered electronic devices ) according to the following factors:
  - the battery's charging percentage;
  - external temperatures;
  - battery wear and tear;
  - +/- 2%.

## ICONS SHOWING THE BATTERY CHARGE STATUS:

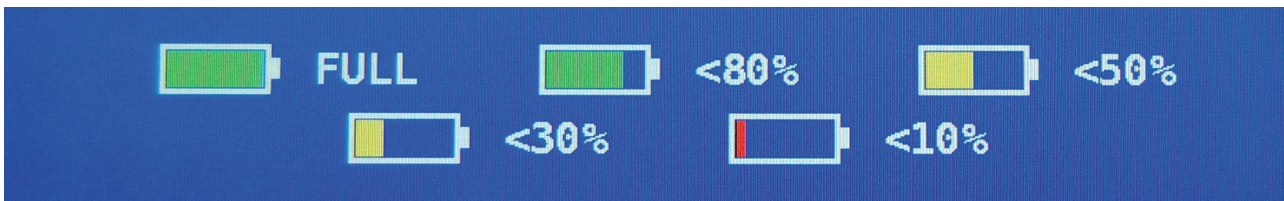

## BATTERY AUTONOMY:

The battery autonomy is up to 3 hours maximum.



## WARNINGS



### RECHARGEABLE BATTERY

This device contains a built-in Li-PO (Lithium polimer) battery that can be recharged many times.

The battery contains chemicals that might wear with time even if not used. Please dispose of batteries properly.

Do not take the battery pack apart or expose it to extreme temperatures (over 50°C). If the device has been exposed to very low or high temperatures let it rest at room temperature before use.

### RECHARGING THE BATTERY

The Battery must be recharged at room temperature (about 20°C) with the device turned off.

To avoid premature failure of the battery never leave the device with an empty battery for prolonged periods.

# BATTERY TEST & BATTERY REGENERATION

THIS PROCEDURE EXPLAINS HOW TO REGENERATE/CHECK YOUR BATTERIES AND CALIBRATE THE BATTERY CHARGE INDICATOR

## USEFUL ADVICE:

- Charge the batteries every night after use, even if they are not completely discharged;
- Always use the "battery save" & "timer off" functions to increase your meter's autonomy;
- The maximum capacity of the batteries and battery charge indicator's accuracy improves by up to 20% if you carry out many battery test cycles;
- Do not replace the batteries: first carry out 3 to 5 battery test cycles until you recover the maximum capacity of the batteries.

## "BATTERY TEST" INSTRUCTIONS & PROCEDURE:

1. Before carrying out the test connect the meter to the original battery charger:
  - Turn on the meter;
  - Press the volume key and select "configuration menu" (fig. 1);
  - Select the word "meter" and press "ENTER" (fig. 2) & press "ENTER" to confirm;
  - Select "battery test" and select "on" (fig. 2);
  - Press "enter" to confirm;
  - Carefully read the various screens, pressing "enter" in succession;
  - In the last instructions window, select "start" and press "enter" to start the test.

**WARNING:** the procedure will be cancelled if you select "exit" on any screen.

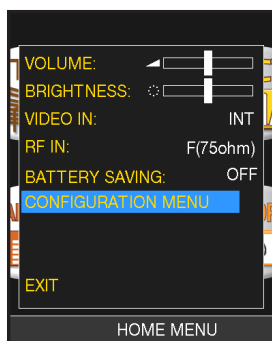

FIG. 1\*

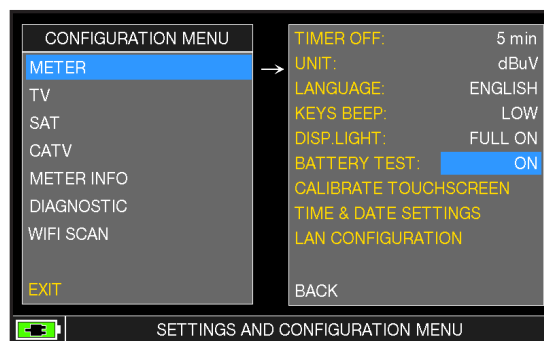

FIG. 2\*

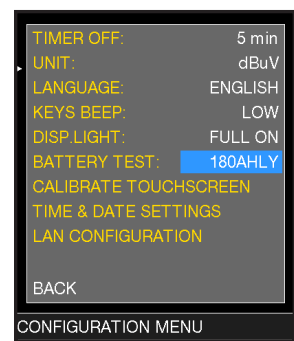

FIG. 3\*

## IMPORTANT ADVICE:

- Do not connect any type of load to the "f" input connector (Inb, tv head-end, amplifiers, etc.).
  - Extract the conditional access module (cam), if it is present in your meter.
2. The battery test takes approx. 12/18 Hours according to the model (charging/discharging/recharging activities and measurement of the battery autonomy), during this time the meter must not be used. At the end of the test the meter will turn off automatically. In order to make sure that the test has been carried out correctly, all the meter's commands are blocked except for the reset function, which remains active so that the meter can be turned off if necessary.
  3. the batteries will be completely charged at the end of the test.
  4. To check the battery test results, enter once again into "meter" in the "configuration menu" and read the results (Fig. 3):

- for example 265BF EY (fig.3) = 265 minutes.

The "Y" of YES confirms that the battery is still good enough, whereas an "N" for NO indicates that it could be faulty, too deteriorated or that the cycle was interrupted.

## IMPORTANT NOTES:

If the test is interrupted using "reset", the battery charge indicator may provide incorrect indications, therefore repeat the battery test procedure.

\* The displays shown in this guide may change according to the model and are subject to change without notice. If you connect your meter, using the s.M.A.R.T. Pro program, from the usb port to the pc, you can download the screens shown above.

# STATO DEI LED DI ALIMENTAZIONE (MAINS) E DI CARICA BATTERIE (CHRG)



STATO STRUMENTO	COLLEGATO ALLA RETE DI ALIMENTAZIONE	▼ LED MAINS	▼ LED BATT CHRГ	NOTE
SPENTO	NO	SPENTO	SPENTO	Batterie sufficientemente cariche.
ACCESO	NO	SPENTO	SPENTO	Funzionamento a batteria.
SPENTO	NO	SPENTO	Lampeggiante 2 SECONDI OFF 0,5 SECONDI ON	Lo strumento non si accende. Ricaricare le batterie.
SPENTO	SI	ACCESO	Lampeggiante 0,5 SECONDI OFF 0,5 SECONDI ON	Temperatura batterie anomala. Il ciclo di ricarica è stato sospeso momentaneamente e si riattiverà automaticamente.
SPENTO	SI	ACCESO	ACCESO	Batterie in carica veloce.
SPENTO	SI	ACCESO	SPENTO	Carica batterie completata
SPENTO	<b>CON ALIMENTATORE NON ORIGINALE ROVER</b>	Lampeggiante 0,5 SECONDI OFF 0,5 SECONDI ON	SPENTO	<b>Lo strumento non si accende. Controllare il trasformatore di alimentazione deve essere 12 Vdc e non 18 Vdc.</b>
IN ACCENSIONE	Indifferente	LAMPEGGIA 15 VOLTE	SPENTO	Strumento in fase di accensione
ACCESO	Indifferente	LAMPEGGIANTI CONTEMPORANEAMENTE 0,5 SECONDI OFF - 0,5 SECONDI ON		Lo Strumento ha rilevato un'anomalia e si spegne automaticamente.
ACCESO	SI	LAMPEGGIANTI ALTERNATIVAMENTE 1 SECONDO OFF - 1 SECONDO ON		BATTERY TEST in esecuzione. Lo Strumento carica e scarica le Batterie AUTOMATICAMENTE

# METER MAINTENANCE

## CLEANING THE METER

Cleaning the meter from dust and dirt is easy and helps maintaining it in optimal work conditions through the years. The cleaning procedure is simple and quick and requires only minor attention. Never use chemical aggressive products (diluent) and/or abrasive or rough clothes which may damage plastics and displays.

Always use a soft cloth, damped with a simple water and alcohol solution or a de-greasing not abrasive liquid soap.

Keyboard and display should be gently cleaned. Rubbing the keyboard and/or the display(s) may seriously damage their functions.

## MAINTENANCE AND CARE OF THE METER

This meter has been designed to withstand severe conditions of use. Even so, its life may be prolonged by respecting some simple and effective rules:

- The meter has not been designed to withstand high temperatures (over 60°C or 140° F). Those temperatures can be easily reached when the meter is left in a car, especially behind the windshield, or in the trunk. The LCD display and/or other details may easily be damaged by the extreme temperature.
- The internal battery may rapidly lose its efficiency if exposed to high or low temperatures. This will result in reduced autonomy of the meter when powered by internal battery.
- When recharging the internal battery, do allow a good air circulation around the meter and the adapter: do not cover it with clothes and do not recharge the battery when the meter is contained in its transport case
- The meter is not waterproof, even if it is protected against incidental water drops. In case of contact with water, electronic circuits may be damaged, allow the meter to dry thoroughly before trying to turn it on. Do not use hairdryer or other strong heating sources, but just leave the meter in quiet air. If possible, contact Rover Laboratories S.p.A. Technical Assistance.

# SERVICE NOTES and GUARANTEE REGULATIONS

(CEE and EXTRA CEE)

ROVER Laboratories. S.p.A. has a standard guarantee period of 12 months.

This is extended to 24 months for countries within the European Community, and in any case, in accordance with the laws and/or possible regulations applied in your country.

## GUARANTEE REGULATIONS:

1. IMPORTANT: the guarantee is valid only upon the presentation of invoice or receipt to ROVER Laboratories S.p.A. The purchase date must be clearly indicated on the invoice/receipt.
2. The guarantee covers the replacement free of charge of parts only, when malfunctioning is solely due to manufacturing faults. The faults must be identified and defined by ROVER personnel only.
3. The guarantee is void if:
  - a. the equipment is tampered with or repaired by non-authorized personnel
  - b. damage is found, caused by the incorrect use of the equipment, without following the advice explained in the User's Guide accompanying the equipment.
  - c. damage is found caused by the use of the equipment in unsuitable working environments.
4. The following parts are not covered by the guarantee:
  - a. Parts subject to wear, such as aesthetic ones, keyboard, plastic chassis, etc.
  - b. Batteries: 3 months from the date of purchase, if original.
  - c. Bags and carrying cases, including shoulder straps.
5. The equipment can not be replaced and the guarantee is extended after the repair of a fault.

## SERVICE NOTES AND PROCEDURES:

6. The equipment can only be repaired by the manufacturer or by an authorized ROVER Laboratories service center:
  - a. *Before returning the meter for repair, always contact the distributor where you purchased the unit or an authorized service center if present in your area to obtain the return procedure for your analyzer. If no authorised ROVER service centers are available in your area, please contact ROVER Laboratories S.p.A. directly at the following data:*
    - **wecare@roverinstruments.com**
    - **+39 030 990 6894**      **Fax number**
  - b. *Important: please take note that non-authorized returns for repair to ROVER Laboratories S.p.A. will be rejected.*
  - c. *When returning the meter, always send it with the following documentation attached:*
    - *the fully-compiled FAULT IDENTIFICATION FORM*
    - *transport document*
    - *the eventual request for an estimate of repair costs*
  - d. *Please note that the request for an estimate of repair costs must be submitted upon return of the analyzer with a written note. If the repair cost estimate is not accepted, ROVER Laboratories reserves the right to charge the customer for the estimate costs analysis.*

7. Risks and costs for transport to ROVER Laboratories S.p.A. must be sustained by the buyer. After repair, if the equipment is under guarantee, ROVER Laboratories S.p.A. will pay for the transport returning the goods to the customer. If the instrument is not under guarantee, after repair, the equipment will be returned by courier service with the amount to be paid by the customer shown on the invoice.
8. The guarantee does not cover compensation for direct or indirect damages of any kind to people or goods caused by the use of the equipment and/or compensation caused by the suspension of use due to eventual repairs.
9. ROVER Laboratories S.p.A. is not responsible for eventual tampering and/or modifications that may cause the goods to no longer adhere to the European "CE" regulations, especially regarding EMC and safety.
10. ROVER Laboratories instruments is recognised and is fully compliant with DVB regulations and specifications (ETS 300 421-12/94) and is consequently marked with the DVB logo.

## DISPOSAL OF ELECTRONIC EQUIPMENT

Disposal of electric/electronic equipment (applicable in all CEE countries and wherever separate waste collection system is applied).

This symbol on the packaging indicates that the product should not be considered as domestic waste. The product, at the moment of disposal, should be brought to a waste collection point with the proper facilities to manage electrical/electronic appliances.

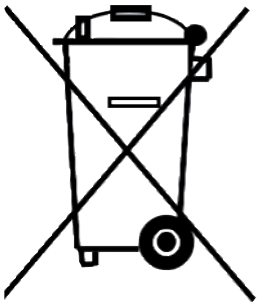

Electric/electronic appliances, if not disposed of correctly, may have negative consequences on your health and environment.

Furthermore, a proper recycling procedure helps maintaining natural resources.

For more information about the correct disposal of this product, please refer to your local waste management offices or the shop where this product was bought.

# FAULT IDENTIFICATION FORM (RMA)

To: ROVER INSTRUMENTS SERVICE DEPARTMENT • Fax: +39.030.9906894  
E-mail: [wecare@roverinstruments.com](mailto:wecare@roverinstruments.com) • Subject: FAULT Identification Form

## PLEASE FILL IN ALL AREAS. CUSTOMER INFORMATION:

- Date..... Company: .....
- Name and surname of the holder \* : .....
- Company address \* : .....
- City \* : ..... ZIP code \* : .....
- Address delivery/pickup, a subsidiary of \* : .....
- City \* : ..... ZIP code \* : .....
- VAT \* : .....
- Tax code \* : .....
- Telephone: .....
- E-mail \* : .....
- Reference person: .....
- Bank support \* : .....
- IBAN code \* : .....

\* Fields NOT required for official ROVER dealers (required for any end customer).  
N.B. Please enter the TAX CODE even if it the same as your VAT number. In the case of sole proprietorship, please communicate the name and surname of the owner.

## METER INFORMATION:

- Meter Model: .....
- Purchase date: .....
- Copy and invoice number (if under warranty): .....
- Bought from: .....
- Software Version (SW): ..... (optional)
- Hardware Version (HW): ..... (optional)
- Serial Number (S.NO): .....

**NOTE:** the information relevant to: model, serial number, firmware/hardware version are shown on the first display after you switch on (start up), or on the meter's information display in the configuration menu. If the meter does not switch on, you can find the meter's serial number on the label placed on the back of the meter.

## DETAILED and ACCURATE DESCRIPTION OF FAULT:

Please describe and attach the fault, especially if OCCASIONAL, or if it occurs ONLY under certain conditions: for example "cool instrument" or "warm instrument", after no. minutes of operation, etc.  
We suggest you provide photographs of the damaged parts or attach a movie that shows the problem on the display. If descriptions of the fault are incomplete and we are unable to reproduce the fault in our laboratories, we may have to resend you the instrument unrepared.

.....  
.....  
.....  
.....  
.....  
.....

(\*) add lines if more space is needed for your description.

TIMING OF REPAIRS: The applicable Repair times are 10 working days (barring unforeseen circumstances).  
WARRANTY REPAIRS: Repairs are guaranteed for 3 months on the same intervention.

**DO NOT SEND ROVER YOUR INSTRUMENT UNTIL YOU HAVE REQUESTED AND RECEIVED OUR "RMA" AND BAR CODE, WITH SHIPMENT INSTRUCTIONS, OTHERWISE THE INSTRUMENT WILL BE REJECTED ON ARRIVAL AT ROVER.**

To receive information regarding the status of your authorization, write to: [wecare@roverinstruments.com](mailto:wecare@roverinstruments.com) quoting your "RMA" number



# SUGGESTED VALUES

This table shows the suggested measurements at a user's socket for the main digital modulations.



**SUGGESTED VALUE TO:** SUBSCRIBER SOCKET, KUNDEN ANTENNEN DOSE, PRESA UTENTE, PRISE DE L'ABONNE', TOMA FINAL DE USUARIO, АБОНЕНТСКИЙ РАЗЪЕМ

DVB-S QPSK			DVB-S2 8PSK			DVB-T-H & GB COFDM			DVB-T2 & GB COFDM			ATSC (USA) 8VSB		
PARAM.	MIN	TYP.	PARAM.	MIN	TYP.	PARAM.	MIN	TYP.	PARAM.	MIN	TYP.	PARAM.	MIN	TYP.
AVG PWR	40 dB $\mu$ V	50 dB $\mu$ V	AVG PWR	40 dB $\mu$ V	50 dB $\mu$ V	AVG PWR	40 dB $\mu$ V	50 dB $\mu$ V	AVG PWR	40 dB $\mu$ V	50 dB $\mu$ V	AVG PWR	-15 dBmV	-5 dBmV
NOISE MARG.	3 dB	6 dB	NOISE MARG.	3 dB	6 dB	NOISE MARG.	6 dB	9 dB	NOISE MARG.	6 dB	9 dB	NOISE MARG.	2 dB	9 dB
aBER post Viterbi	2x10 <sup>-6</sup>	2x10 <sup>-8</sup>	PER 8PSK	<1x10 <sup>-7</sup>	<1x10 <sup>-8</sup>	aBER post Viterbi	2x10 <sup>-6</sup>	2x10 <sup>-8</sup>	PER	1x10 <sup>-7</sup>	1x10 <sup>-8</sup>	bBER pre Trellis	1x10 <sup>-3</sup>	<1x10 <sup>-6</sup>
MER QPSK 2/3 FEC	9 dB	12 dB	MER 8PSK 2/3 FEC	11 dB	14 dB	MER 64 QAM 2/3 FEC	25 dB	28 dB	MER 256 QAM 2/3 FEC	25 dB	28 dB	bBER post Trellis	3x10 <sup>-6</sup>	<1x10 <sup>-8</sup>
MER QPSK 3/4 FEC	10 dB	13 dB	MER 8PSK 3/4 FEC	12 dB	15 dB	MER 16 QAM 2/3 FEC	20 dB	23 dB	MER 256 QAM 3/4 FEC	26,5 dB	29,5 dB	aBER pre R.S.	3x10 <sup>-6</sup>	<1x10 <sup>-8</sup>
MER QPSK 5/6 FEC	11 dB	14 dB	MER 8PSK 5/6 FEC	13 dB	16 dB	MER QPSK 2/3 FEC	14 dB	17 dB	MER 256 QAM 5/6 FEC	28,5 dB	31,5 dB	MER	16 dB	23 dB



made in Italy





# NOTE

A series of horizontal dashed lines for writing notes.

# ACCESSORIES SUPPLIED

## LIST OF PROVIDED ACCESSORIES:

- Soft BAG
- Removeable side pocket for tools and accessories
- Shoulder strap
- Safety antenna mast attachment Strap
- USB 2.0 cable for PC connection
- Battery charger power supply
- User guide (hard copy)
- User guide (CD or USB)
- F Female - F Female connector
- BNC Female - F Female connector
- IEC Female - F Female connector
- QUICK F Male - F Female connector

**NOTE:** This list of accessories is subject to change without notice and depends on the meter's configuration.

# INDEX

- 2 – Get to know your HD TAB 900/900 Plus
- 4 – Multi-porpose bag
- 5 – HOME and Navigation
- 10  Configuration
- 14 – ScreenShot
- 15  SAT Measure
- 30  V Measure
- 41  CATV Measure
- 49–  SPECTRUM Analyzer
- 50  OPTIC Measure
- 53  WI-FI Analyzer
- 54  BARSCAN check all channels level/power
- 55  MEMORY
- 61  TV & CATV Special Functions
- 66  SAT Special Functions
- 67 – Optional APPS
- 70 – SERVICE & SUPPORT web registration & sw upgrades
- 70 – S.M.A.R.T. program
- 71 – UPGRADE SOFTWARE procedure
- 72 – MEMORY PLAN UPGRADES procedure
- 73 – LI-ION polimer BATTERIES
- 73 – WARNINGS
- 74 – BATTERY TEST & BATTERY REGENERATION
- 75 – POWER SUPPLY (mains) & battery charge (CHRG) LED status
- 76 – METER MAINTENANCE
- 77  SERVICE NOTES & GUARANTEE REGULATIONS
- 78  DISPOSAL OF ELECTRONIC EQUIPMENT
- 79 – RMA: FAULT IDENTIFICATION FORM
- 80 – SUGGESTED VALUES
- 82 – ACCESSORIES supplied

# CUSTOMER SUPPORT

wecare@roverinstruments.com

skype® only for call  
wecare.roverinstruments



UG-HDTAB900ePLUS-EN-V1

Designed & Assembled in Sirmione, Europe.

RO.VE.R. LABORATORIES S.p.A. Via Parini 2, 25019 Sirmione (BS) Italy tel. +39 030 9198 1 fax +39 030 990 6894

Product specification are subject to change without notice . All trademarks used are properties of their respective owners.