

	A x B		85 / 105 mm
1	50 x 80 mm	756 01	756 81 + 756 21
	50 x 105 mm	756 02	756 81 + 756 22
2	50 x 130 mm	756 03	756 81 + 756 23
	50 x 145 mm	756 04	756 81 + 756 24
3	50 x 180 mm	756 06	756 81 + 756 26

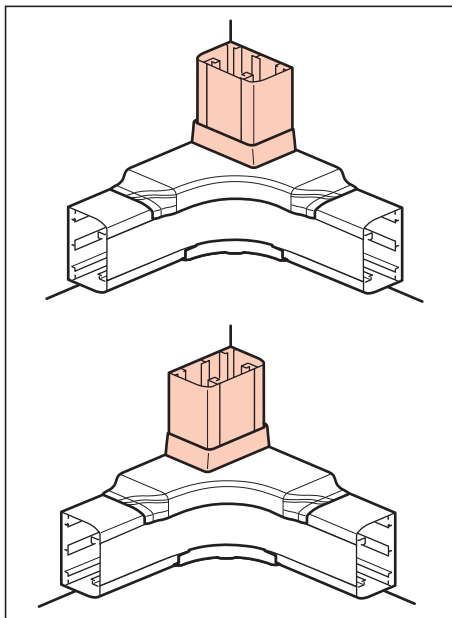

1

304 18

A B C

304 18

A B C

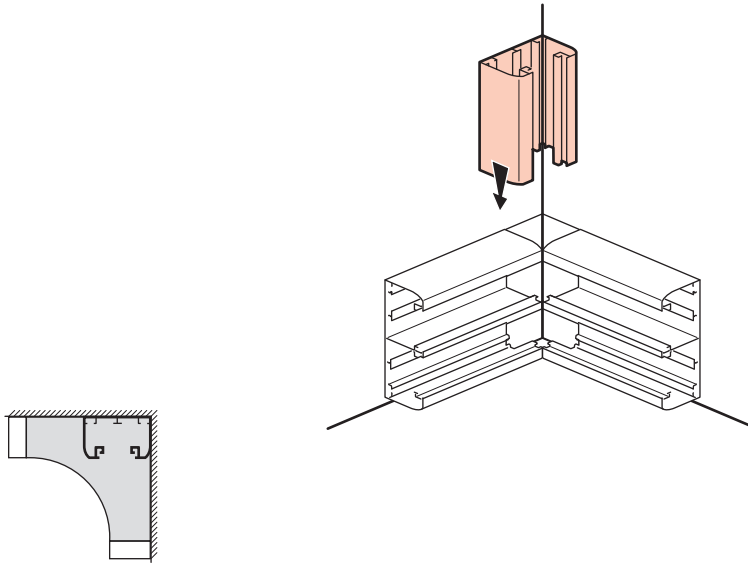

2

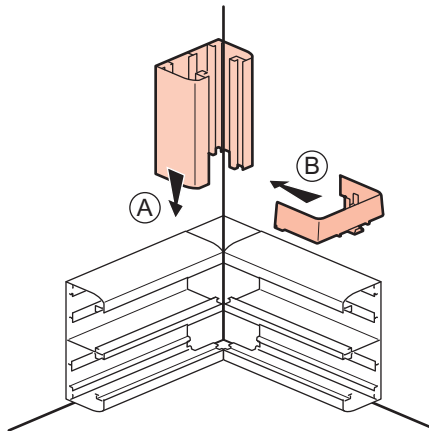
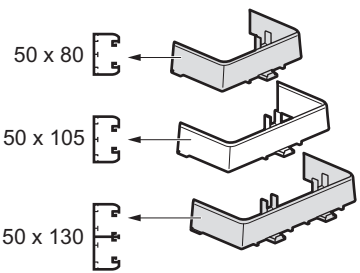
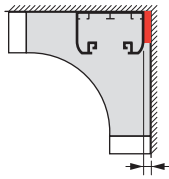

3

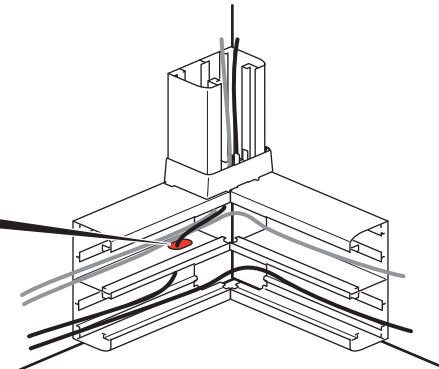
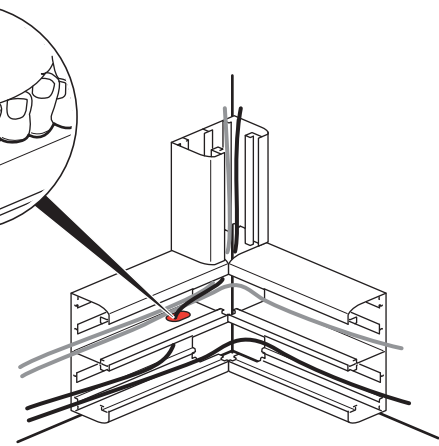
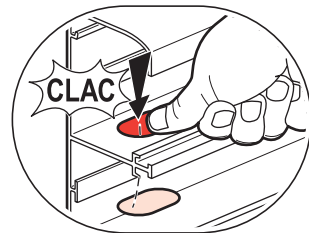
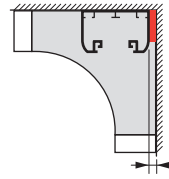
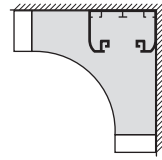

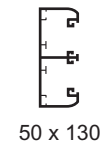
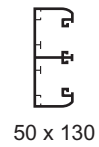
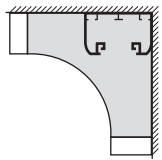
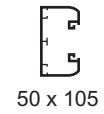
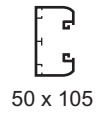
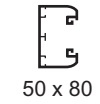
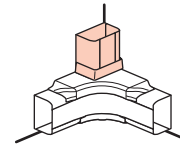
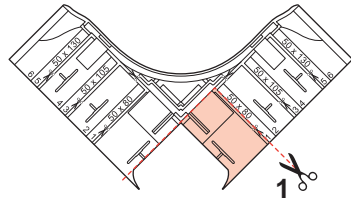
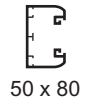
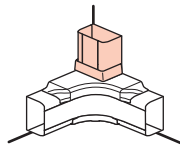

4

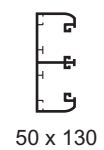
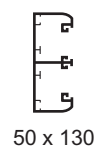
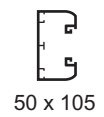
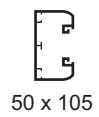
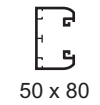
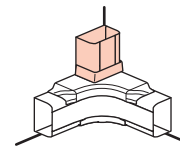
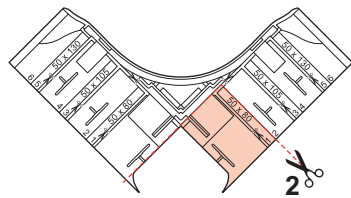
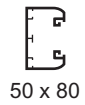
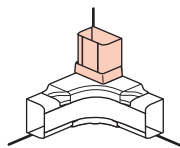
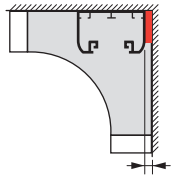

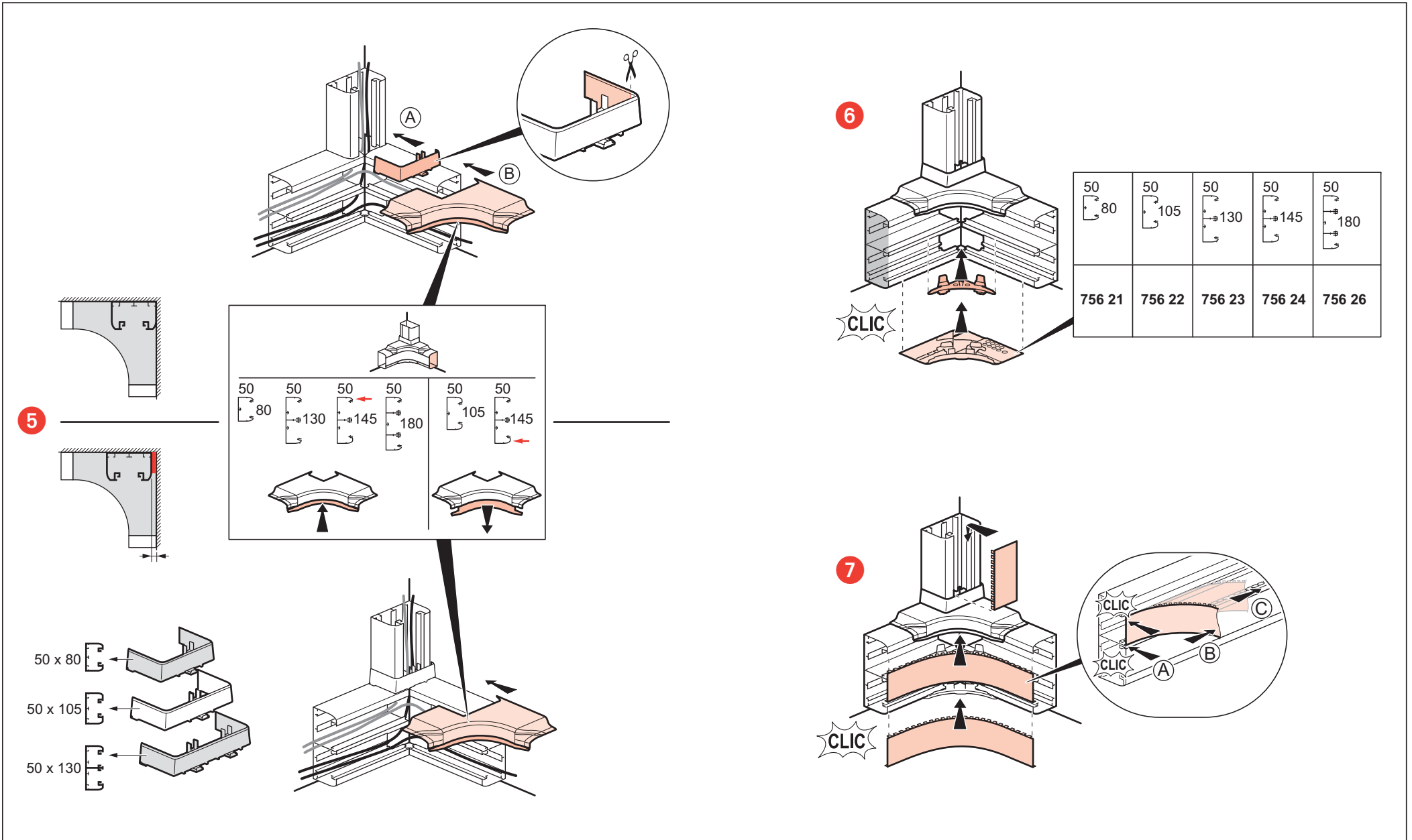

FR LU BE Respecter strictement les conditions d'installation et d'utilisation.

NL BE Neem de installatie- en gebruiksvoorwaarden nauwgezet in acht.

GB IE Strictly comply with instructions for installation and use.

DE AT LI Einbau- und Gebrauchsanleitungen sind genau zu beachten.

ES Respetar estrictamente las condiciones de instalación y de utilización.

IT Rispettare scrupolosamente le condizioni d'installazione e uso.

PT Respeitar estritamente as condições de instalação e de utilização.

GR CY Τηρήστε αυστηρά τις συνθήκες εγκατάστασης και χρήσης.

PL Ścisłe przestrzegaj instrukcji dotyczących instalacji i użytkowania.

TR CY Yerleşirme ve kullanım koşullarına titizlikle riayet ediniz.

HU Tartsa be pontosan a beszerelési és használati feltételeket.

FI Noudata asennus- ja käyttöohjeita tarkoin.

SE Iaktta noggrant installations- och användningsföreskrifterna.

CZ Důsledně dodržujte instalační a uživatelské podmínky.

SK Prísne dodržiavajte podmienky, za ktorých sa má prístroj inštalovať a používať.

SI Natančno upoštevajte pogoje za montažo in uporabo.

DK Installations- og anvendelsesbetingelserne skal overholdes nøje.

MT Imxi skond l-istruzzjonijiet mogħtija għall-installazzjoni u l-użu.

EE Pidage täpselt kinni paigaldus-ja kasutamistingimustest.

LV Stingri ievērot uzstādīšanas un lietošanas noteikumus.

LT Griežtai laikykitės instaliavimo ir naudojimo sąlygų.

NO Installasjons- og bruksbetingelsene må nøye overholdes.

IS Fylgja skal vandlega öllum reglum um uppsetningu og notkun.