

• LIGHT UP Détecteur de couloir ON-OFF

• LIGHT UP Corridor detector ON-OFF

0 485 53



- Documentation technique disponible dans votre langue => Scanner le QR code
- Technical documentation available in your language => Scan the QR code
- Documentación técnica disponible en su idioma => Escanear el código QR
- Documentazione tecnica disponibile nella vostra lingua => Scansionare il codice QR
- Technische documentatie beschikbaar in jouw taal. => Scan de QR-code

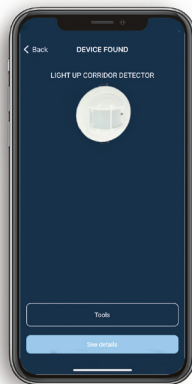
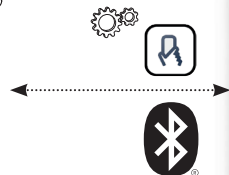
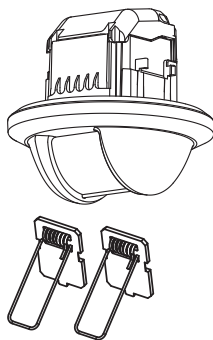

Legrand CLOSE UP



	110 - 230 V~
	50 / 60 Hz
	2 x 1.5 mm ² ou/or 1 x 2.5 mm ²
	-10°C / +30°C
	PIR
	100 lux

	10 mn	
	<ul style="list-style-type: none"> • Mode Passage • Walkthrough mode 	
Hauteur/Height 1.7 m mini	3 m x 24 m (2.5 m)	
Bluetooth®	5.0 compatible 4.2	<ul style="list-style-type: none"> • Portée : 10 m • Reach: 10 m
Radio	2.4 - 2.483 GHz	
<ul style="list-style-type: none"> • Consommation en veille : • Standby consumption : 	Charge/Load OFF → 0,53 W	Charge/Load ON → 1,2 W

- F (Fréquence) : 2,4 à 2,483 GHz
- P (Puissance) : <100 mW

- F (Frequency) : 2.4 to 2.483 GHz
- P (Power) : <100 mW

- Le soussigné, **LEGRAND**, déclare que l'équipement radioélectrique du type réf. **0 485 53** est conforme à la directive **2014/53/UE**. Le texte complet de la déclaration UE de conformité est disponible à l'adresse suivante : www.legrand.com/ecatalogue
- **LEGRAND**, declares that radio equipment of the type Cat. no. **0 485 53** complies with Directive **2014/53/EU**. The full text of the EU declaration of conformity can be found at: www.legrand.com/ecatalogue

- Retour configuration usine
- Reset button

- Capteur infra-rouge
- PIR sensor

- LED de présence
- Presence LED

- LED Bluetooth®
- Bluetooth® LED

- Bouton radio bind
- Radio bind button
- Bouton radio network
- Radio network button

- LED radio
- Radio LED

- Capteur de luminosité
- Daylight sensor

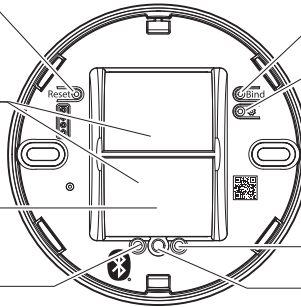

<ul style="list-style-type: none"> • Bouton radio network • Radio network button 	<p>< 0.5s Rejoindre un réseau / Ouverture et fermeture réseau</p> <p>> 5s Reset Radio</p>	<p>< 0.5s Join network / Network opening and closing</p> <p>> 5 s Radio reset</p>	
<ul style="list-style-type: none"> • Bouton bind • Radio bind button 	<p>< 0.5s Création réseau / Initiator binding</p> <p>> 5s Target Binding</p>	<p>< 0.5s Network creation / Binding Initiator</p> <p>> 5 s Target Binding</p>	
<ul style="list-style-type: none"> • Bouton Reset • Reset button 	<p>< 0.5s Redémarrage</p> <p>> 5s Retour configuration Usine</p>	<p>< 0.5s Reboot</p> <p>> 5s Return to factory settings</p>	
<ul style="list-style-type: none"> • LED radio • Radio LED 	<p>Echec Opération radio</p> <p>Reset produit (<i>rouge flash</i>)</p>	<p>Radio operation failed</p> <p>Product reset (<i>flashing red</i>)</p>	
	Réseau radio ouvert (<i>magenta fixe</i>)	Open radio network (<i>steady magenta</i>)	
	Procédure de join réseau en cours (<i>magenta clignotant</i>)	Network join procedure in progress (<i>blinking magenta</i>)	
	Procédure de binding en cours (<i>bleu clignotant</i>)	Binding procedure in progress (<i>blinking blue</i>)	
	Mise à jour (<i>cyan clignotant</i>)	Update (<i>blinking Cyan</i>)	
	Anomalie produit (<i>blanc fixe</i>)	Product anomaly (<i>steady white</i>)	
	Démarrage (<i>jaune fixe</i>)	Start-up (<i>steady yellow</i>)	
<ul style="list-style-type: none"> • LED de présence • Presence LED 	<p>80s au démarrage du produit</p> <p>1s à chaque détection (<i>vert fixe</i>)</p>	<p>80s at product start-up</p> <p>1s each detection (<i>steady green</i>)</p>	
<ul style="list-style-type: none"> • LED Bluetooth® • Bluetooth® LED 	Produit appairé avec un smartphone (<i>bleu fixe</i>)	Product paired with a smartphone (<i>steady blue</i>)	

230 V~	2000 W	8.5 A	1000 VA	4.3 A	10x(2x36 W)	4.3 A	500 VA	2.1 A	1000 VA	4.3 A	350 VA	2.1 A	I max. ≤ 2A
110 V~	1000 W		500 VA		5x(2x36 W)		250 VA		500 VA		175 VA		

- ① - Lampe à incandescence et Halogène
- ② - Lampe halogène à transformateur ferromagnétique ou électronique séparé
- ③ - Tube fluorescent
- ④ - Lampe fluocompacte à ballast intégré
- ⑤ - Lampe fluocompacte à transformateur ferromagnétique ou électronique séparé
- ⑥ - Lampe à LEDs
- ⑦ - Contacteur

- ① - Incandescent and Halogen lamps
- ② - Halogen lamp with separate ferromagnetic or electronic transformer
- ③ - Fluorescent tubes
- ④ - Compact fluorescent lamp with integrated ballast
- ⑤ - Compact fluorescent lamps with transformer ferromagnetic or separate electronic
- ⑥ - LED lamp
- ⑦ - Contactor



+

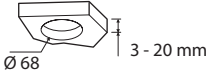

- Le montage et le câblage doivent être réalisés hors tension. **Merci de suivre scrupuleusement les Consignes de Sécurité.**
- Installation and wiring must be carried out with the power off. **Please follow the Safety Instructions carefully.**

1

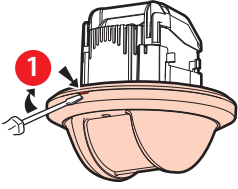

2

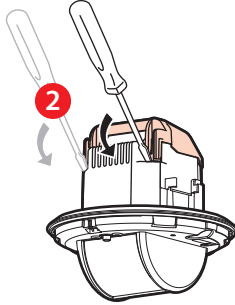

3

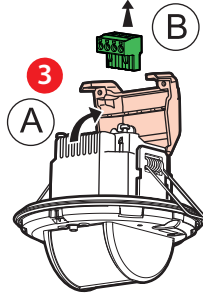

4

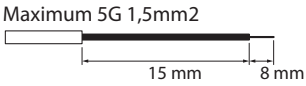
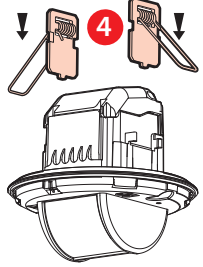

5 mm

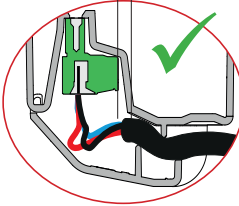

5

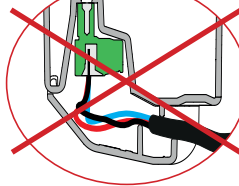
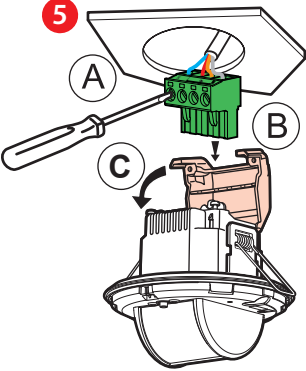

6

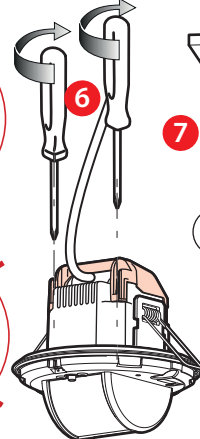

7

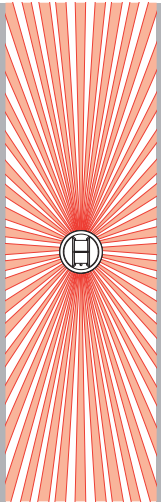
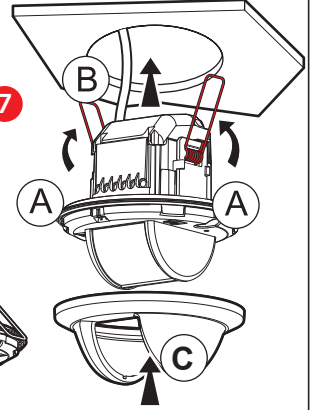

• Couloir • Corridor



• Poteau
• Post

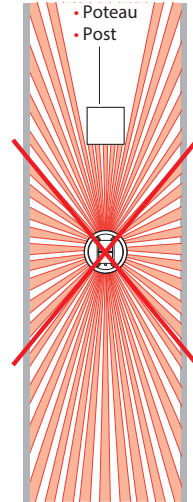

• Câblage

- (*) Ce produit peut être commandé par :
 - Une commande sans fils sans pile (ON/OFF sans variation)
Ou
 - Un bouton poussoir filaire commande filaire (ON/OFF et variation)Et il peut piloter (sans fils) une prise connectée.

• Wiring

- (*) This product can be controlled by:
 - A wireless batteryless control (ON/OFF without dimming)
Or
 - A wired control (ON/OFF and dimming)And it can control (in wireless mode) a connected outlet.

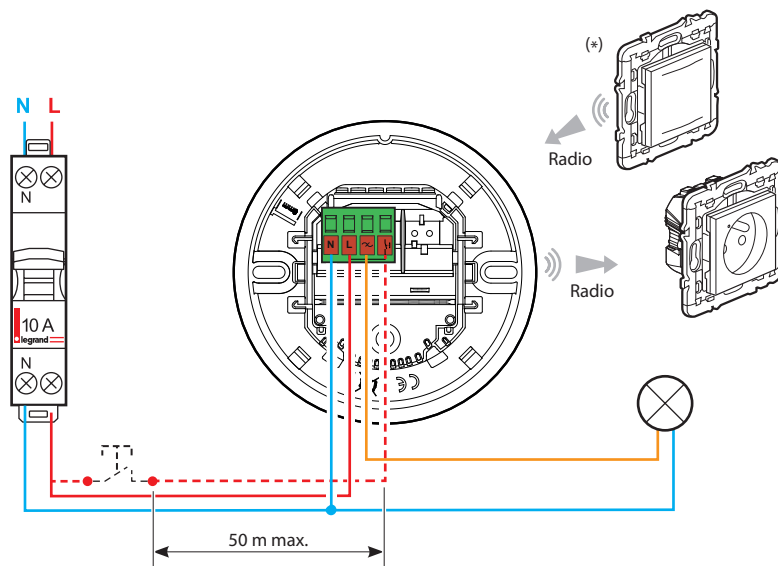

- La distance maximum du bouton poussoir filaire à l'entrée auxiliaire est de 50 m.

- The maximum distance from the wired push-button control to the auxiliary input is 50 m.

(*)

- Possibilité de combiner un commande d'éclairage sans fils et sans pile (maximum 2 par détecteur)
- Possibility of combining a wireless batteryless control (maximum 2 per sensor)

Références / Cat.Nos 0 677 23L/73L/79L, 0 770 53L, 6 000 83L, 5 742 10/39/55, 5 743 24, 7 418 13L/43L/73L

- et une prise connectée (maximum 5 par détecteur)
- and a connected outlet (maximum 5 per sensor)

Références / Cat.Nos 0 677 25A/75A, 0 648 95A, 0 777 11LA, 6 003 91A, 5 742 56/57/58/59, 7 419 11/41/71

- suivant la description des procédures du *Guide LIGHT UP*
- as described in the *LIGHT UP Guide*

• **Maitre/Esclave**

- Le produit est configuré par défaut en **Maitre**.
Pour le passer en **Esclave**, suivre la description dans le **Guide technique LIGHT UP**.
- Le Maitre ne pourra être associé qu'avec 5 détecteurs maximum configurés en esclave.

• **Master/Slave**

- The product is configured as **Master** by default.
To change it to **Slave**, follow the description in the **LIGHT UP Technical Guide**.
- The Master can only be associated with a maximum of 5 slave sensors.

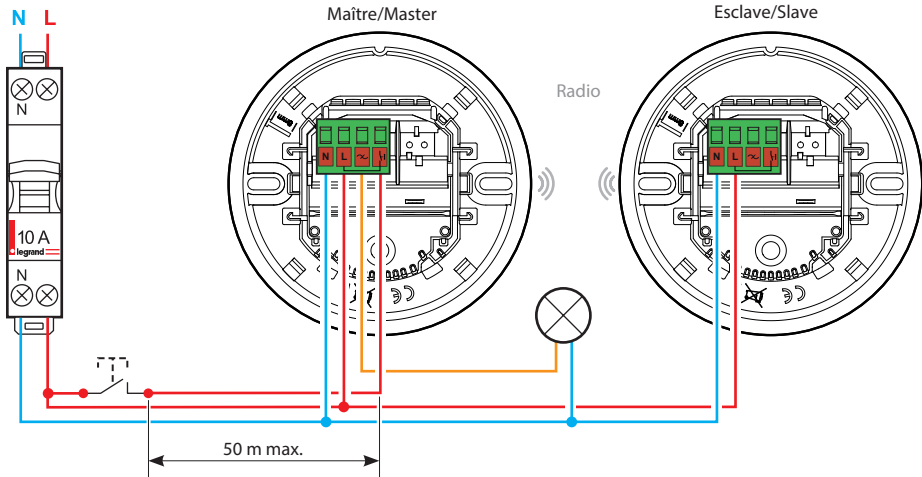

- L'esclave permet d'étendre la zone de détection. Aucune charge ne lui sera associée.
- Dans le cas d'une utilisation en «**Maitre/Esclave**», le poussoir devra être uniquement connecté au détecteur «**Maitre**».

- The slave extends the detection area. No load will be associated with it.
- If used in "**Master/Slave**" mode, the push-button should only be connected to the "Master" detector.

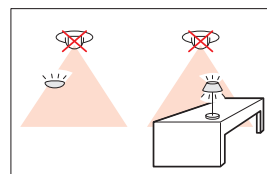
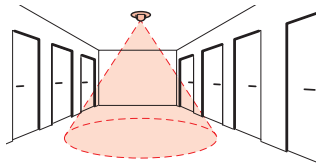
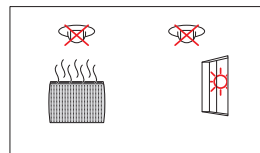
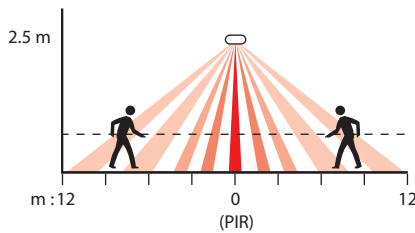



Auto ON/OFF



Manual ON / Auto OFF

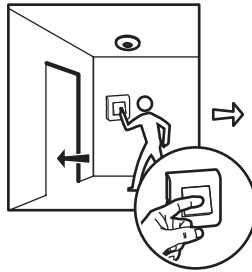
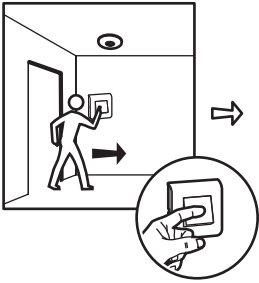

- Approche axiale
- Walk towards

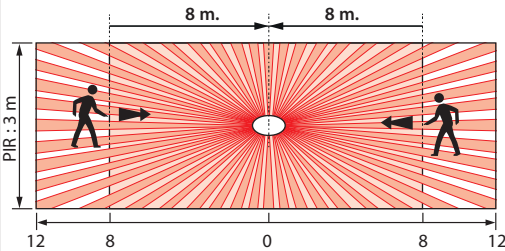

- Approche transversale
- Walk across

