

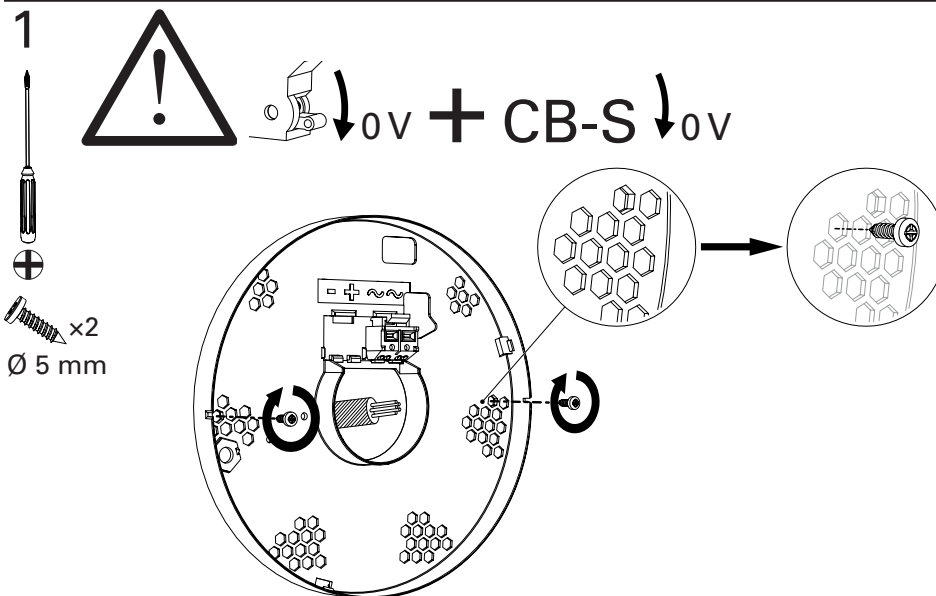

PLANET 400 DISC CG-S

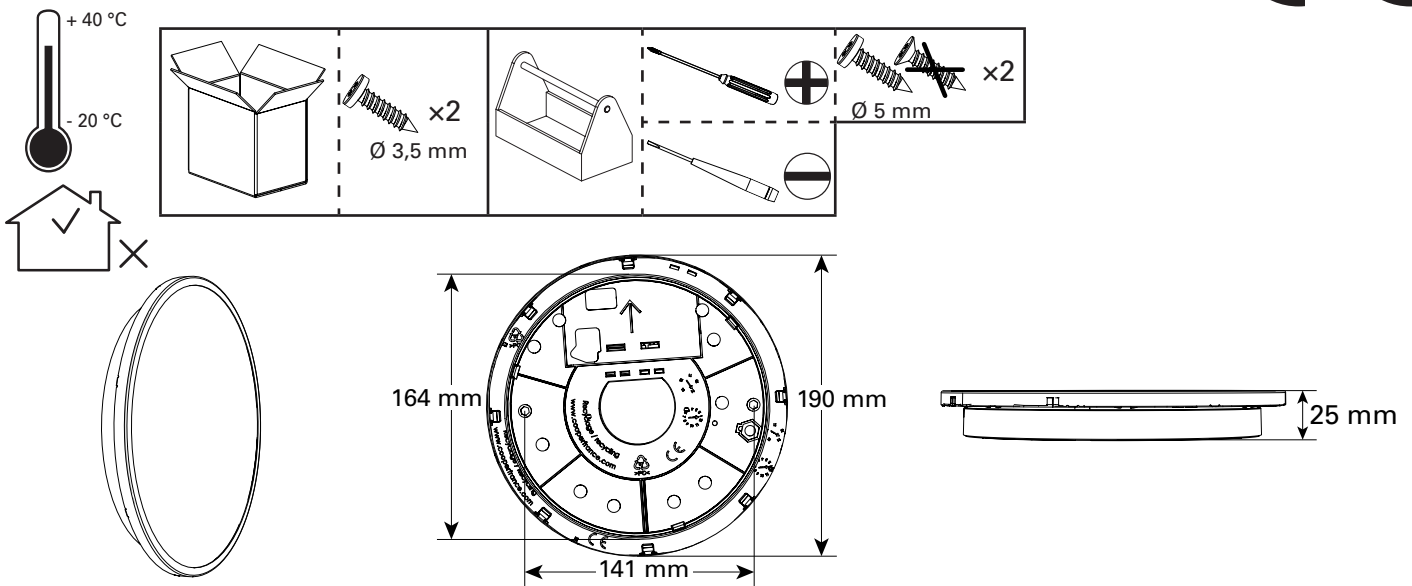

+ option Deckeneinbau-Kit/Kit d'encastrement/False ceiling kit

 LUM10541/
LUM10541 COL

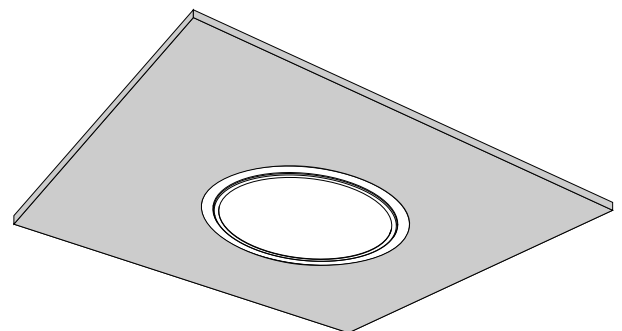

2

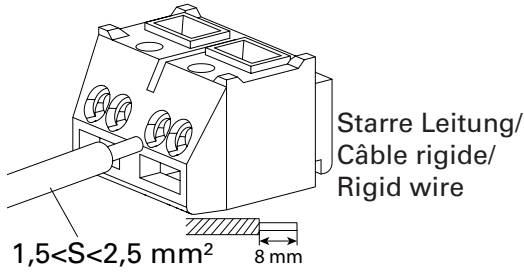

230 V - 50/60 Hz
220 V DC

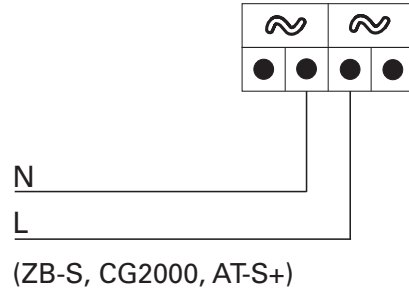

Adressierung/Adressage/Addressing

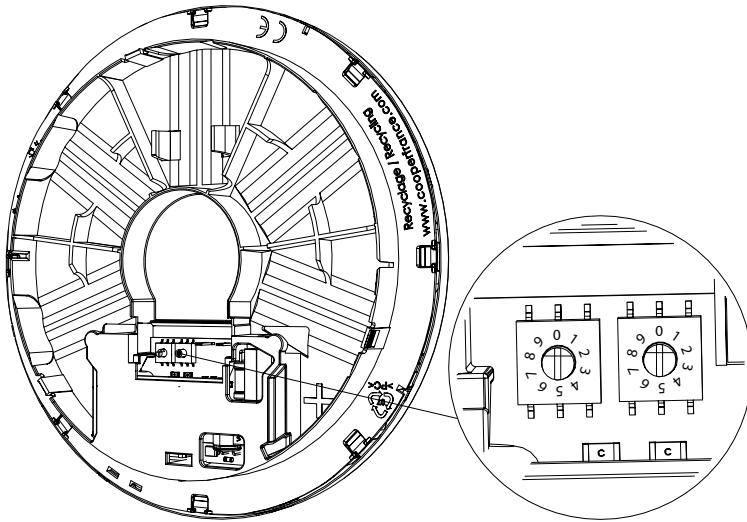

	Keine Adresse/ Pas d'adresse/ No address
	0 + 1 = 1
	0 + 9 = 9
	1 + 0 = 10
	1 + 1 = 11
	2 + 0 = 20
	Max. 20

3 a.

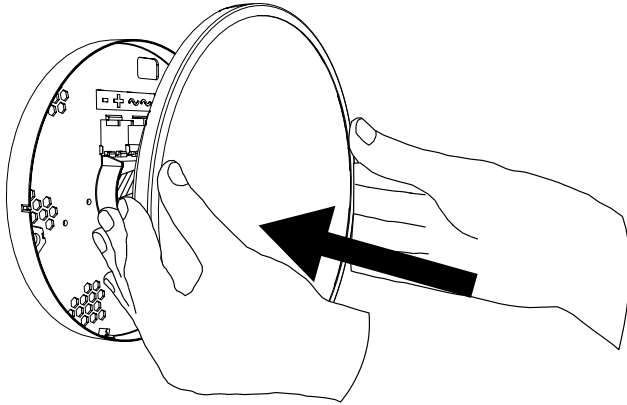

b. option LUM10541/
LUM10541 COL

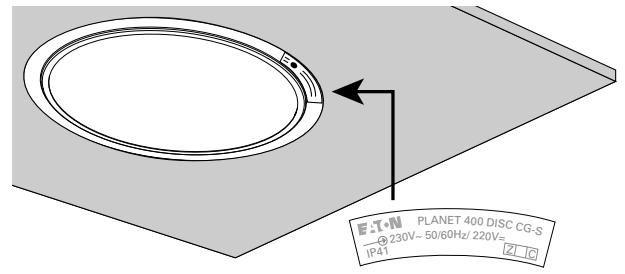

4 IK07

a.

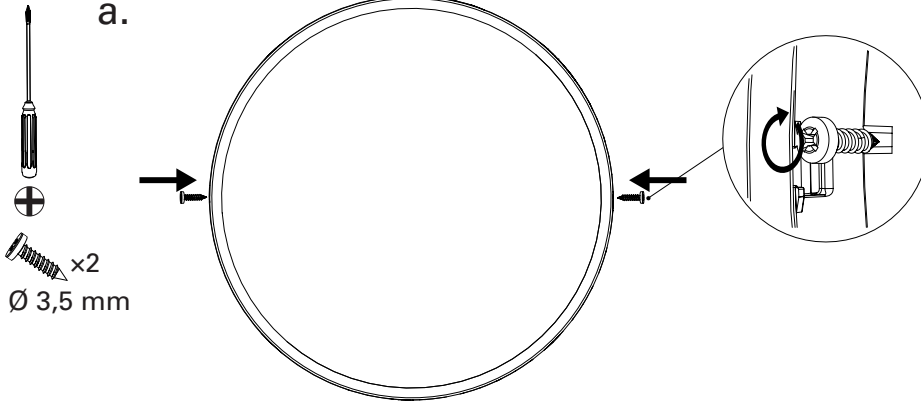

b.

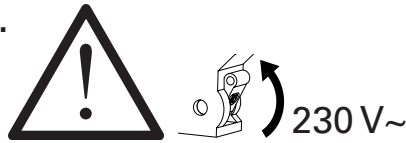

Demontage/Démontage/Disassembling

a.

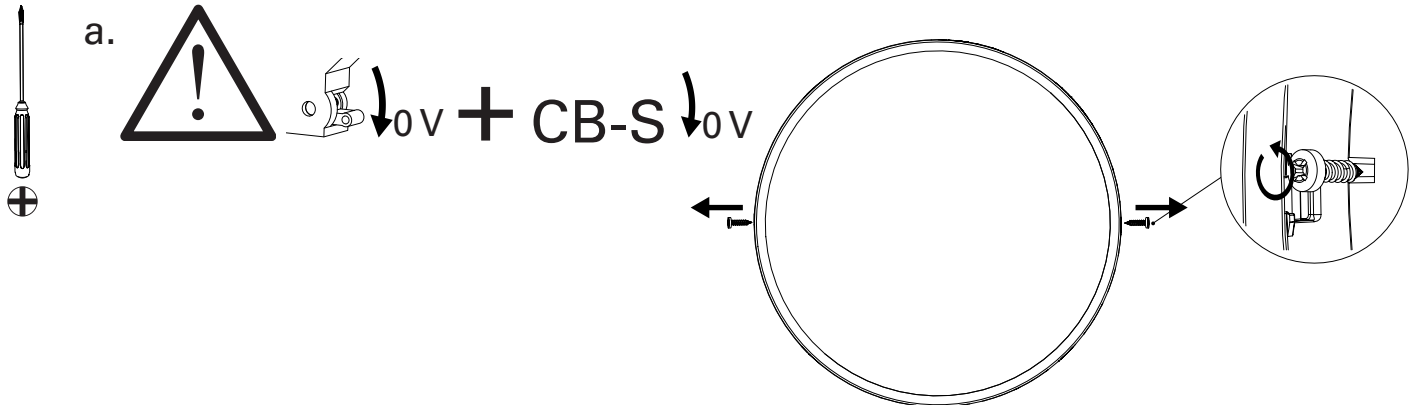

b.

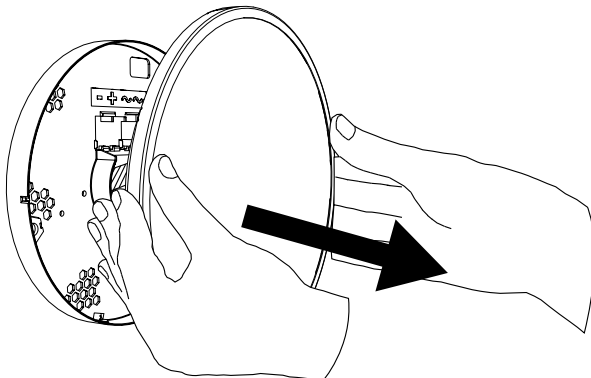



PLANET 400 Disc CG-S

LUM22136

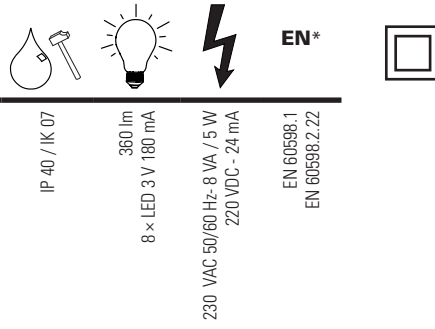

IP 40 / IK 07

360 lm
8 x LED 3 V 180 mA

230 VAC 50/60 Hz- 8 VA / 5 W
220 VDC - 24 mA

EN 60598.1
EN 60598.2.22

Diebstahlschutzschraube/Vis inviolable/Anti-theft screw LUM10490

* laufende Zertifizierung/
certification en cours/
certification in progress

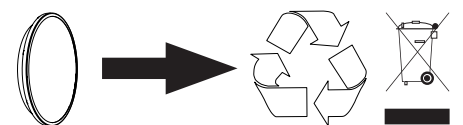

FR : www.recylum.com

